

Climate Emergency Conservation Area Toolkit - England

A methodology to Audit Conservation Areas for Home Retrofit with a worked Conservation Area case study.

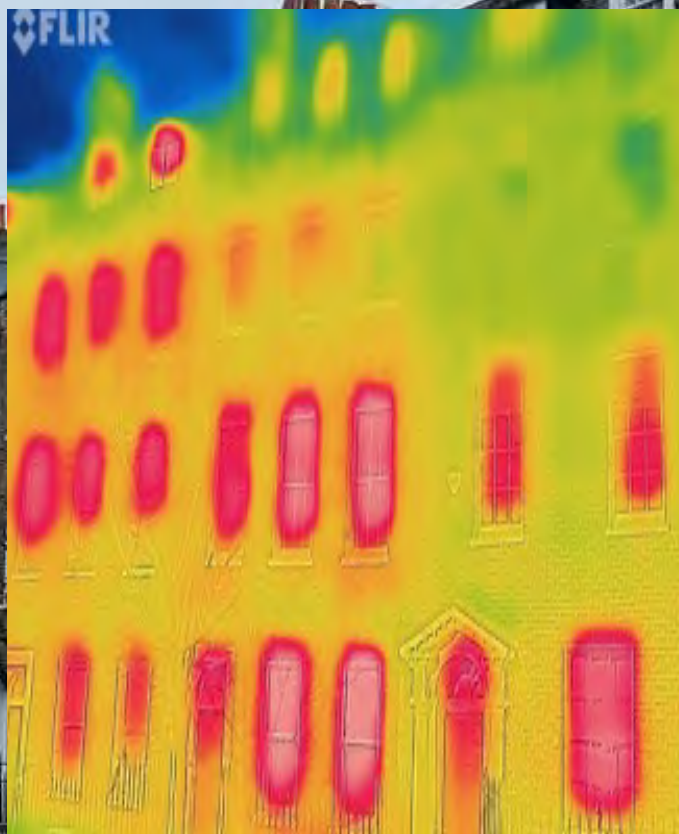

A report for planners, policymakers, and building professionals
Architects Climate Action Network
3 February 2023



ACAN - ARCHITECTS CLIMATE ACTION NETWORK

is a network of individuals within architecture and related built environment professions taking action to address the twin crises of climate and ecological breakdown.

www.architectscan.org

Copyright © Christopher Procter and ACAN
Distributed under Creative Commons license as below
with credit to authors



cover image

Infrared Camera photos of Georgian terrace, with winter outdoor temp 0c, indoor temp 21c shows large window heat losses, blue sky cold & red/white windows hot. Lightweight 1000 mile range Aptera solar electric car parked in front.

Author and Document Design

Christopher Procter

is a RIBA Registered Architect specialising in sustainable residential projects in conservation areas in London. He is a director of Procter-Rihl architects established since 1995 in Islington, London.

The practice is known for a seminal contemporary house in Brazil, winner of a Royal Institute of British Architects worldwide category in 2005, first in South America. The building was listed after only 12 years, as a "structure of value and spatial quality, constituting a significant element of structure in the urban context", (Equivalent to Grade II, UK). In 2008, the practice designed the Pull House, a project which embraced Passive House principles and Offsite Manufacturing. The project received 5 Star energy status for its sustainable features in the state of Vermont, USA. His book 'Architecture and Beyond', a monograph of his studio covering a series of projects, was published in 2017. www.procter-rihl.com.

Chris was the Course Leader in Technical Studies, MA Architecture, at the Royal College of Art for 8 years (2008-2016) where he brought sustainable studies for the first time to the course. In 2011, he took the Passivhaus Design course at the Building Research Establishment (BRE). He has been an active member of ACAN since its founding in 2019 in the Existing Buildings and Planning Policy Groups.

Support of Members of ACAN
Architects Climate Action Network
Existing Buildings working group

Annalisa McSweeney
Barbara McFarlane
Emily Harris
Fiona MacDonald
Gabi Marrero
Mark Webb
Sara Edmonds
Suzy Nelson

with thanks to

Alex Forshaw
Clara Bagenal George
Mina Hasman

Reviewers

Adam Tilford former BRE Passivhaus Instructor
Alan Chandler Dean of Research UEL
Alex Whitcroft Kin, LETI
Alice Brown Conservation Architect
Andrew Myer Retrofit Coordinator
Anna Woodeson Power Up North London, BGY
Chris Twinn LETI, TwinnSustainabilityInnovation
Jane Dann Tibbalds Planning & Urban Design
John Preston IHBC, Heritage Chair STBA
Julie Godefroy Head of Sustainability CIBSE
Leyla Boulton Green Conservation Campaign
Lizzy Westmacott Sustainability ECD Architects
Nigel Griffiths STBA, Sus. Trad. Building Alliance
Rob Prewett Prewett Bizley Architects
Robert Milne Islington Env. Emergency Alliance
Robin Nicholson Edge, Cullinan Studio
Sara Edmonds ACAN
Seb Laan Lomas Architype, ACAN
Suzy Nelson ACAN, U Westminster
Tanuja Pandit PUNL, Power Up North London
Will South Etude, LETI

Table of Contents

page 6	Executive Summary
page 8	London Councils Retrofit Action Plan
page 10	1.0 Context : Introduction
	1.1 Climate Emergency Declarations
	1.2 Coverage Conservation Area England and Bath Conservation Area Coverage London Councils with high percentage of CA Coverage
	1.3 Planning Policy 1.3.1 English Planning Policy 1.3.2 Local Authority Policies
	1.4 Technical- Conservation Practice 1.4.1 First Generation Designation Legislation 1.4.2 Second Generation Appraisal Legislation- Building Audit 1.4.3 Building Detail Element Appraisal in Practice
	1.5 Element Appraisal 1.5.1 Third Generation Building Elements
page 20	2.0 Toolkit (with worked example) Toolkit Scope, Structure, and Worked Example
page 22	2.1 Step 1 - DESIGNATION Existing Condition Characteristics, Boundary, Age, Article 4, & Audit achieved
page 24	2.2 Step 2 - BUILDING AUDIT Appraisal Negative,Neutral,Positive,Listed Audit 173 Buildings 60 Shopfronts
page 26	2.3 Step 3 - BUILDING ELEMENT AUDIT Appraisal Extend audits to building elements
page 28	2.4 Step 4 - ACTION PLAN mechanisms for change Local Development Orders, Local Listed Building Consent Orders
page 30	2.5 Detailed Element Mapping (from 2.3) with proposed Supplementary Planning Document guidance 2.5.1 Roof Extensions -'woolly hats' mapping 2.5.2 Projecting Features - 'ear muff' mapping 2.5.3 Renewables Retrofit - solar mapping 2.5.4 Double or triple windows- 'lenses' mapping 2.5.5 External Insulation -'woolly jumpers' mapping 2.5.6 Shopfronts - 'leg warmers' mapping
page 128	3.0 Appendices
	3.1 Building Audits
	3.2 Shopfront Audits
	3.3 Window Audits
page 159	3.4 CA13 Proposed Guidance Document

Executive Summary

Why is this document needed?

AIMS - The aim of this document is to provide a toolkit with a worked example to update Conservation Area Guidance which will allow more complete Climate Emergency Retrofitting.

CONTEXT - With 20% of total UK carbon emissions coming from our 29 million existing households there is an urgent need to reduce carbon emissions in all housing stock including Conservation Areas.

The 2021 'LETI Climate Emergency Retrofit Guide' estimates that heritage or architectural constraints involve 25% of all UK homes. The LETI Retrofit Guide and the follow up LETI Retrofit Guide- Part 2, detail retrofit options for the majority 75% non-constrained homes with a lesser analysis of the 25% constrained. Further study of heritage areas can address specific issues which would allow deeper retrofit and carbon savings. Heritage or architecturally constrained homes emit more carbon than typical homes, therefore at quarter of all homes they contribute **more than 5% of total Carbon emissions**. This is a percentage that can't be ignored on the road to Net Zero nationwide.

2019 was a turning point for climate change planning policy. In February 2019, the NPPF 2019 (National Planning Policy Framework) strengthened the environmental benefits in planning law. In June 2019, the UK Parliament amended the Climate Change Act with the landmark legal requirement to reach Net Zero by 2050. While for conservation specifically, in February 2019, Historic England released the 'Conservation Area Management Guidance' followed in July 2019, by the government release of PPG 2019 (Planning Policy Guidance). Both planning guidance documents recommend local planning authorities to use positive to negative detailed mapping "identifying opportunities for beneficial change" to make updated Conservation Area Management Plans. (see page 17 & appendices pages 129-137)

This more specific guidance aids LPAs to better meet the 1990 Planning Act requiring regular updated formulation and publication of these plans. This new Appraisal methodology we have classed in this report as **second generational** because of a switch from protection of heritage to identification of harm and opportunity for beneficial change. Unfortunately most councils have not completed these positive/negative Building Audits of their Conservation



LETI Climate Emergency Retrofit Guide, October 2021

<https://www.leti.uk/retrofit>

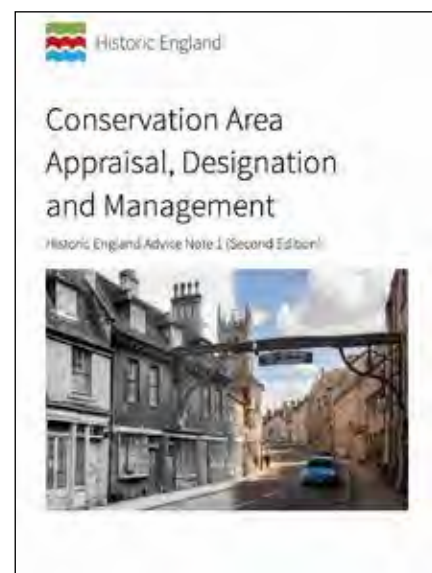

Historic England, February 2019

<https://historicengland.org.uk/images-books/publications/conservation-area-appraisal-designation-management-advice-note-1/>

Area Buildings. Many CA documents are also quite old therefore: updated guidance can address both heritage and beneficial change for climate mitigation. Conservation Areas with their unique Guidance Documents allow councils to tailor policy with precise local knowledge. In London the collective of London Councils commissioned a 'Retrofit London Housing Action Plan' July 2021, which clearly sets out needs for Local Planning and Conservation Area Reform, see following pages.

The housing stock in England is diverse; therefore typology templates with complementary planning policy are best determined at a local level. Some Local Authorities carry a much heavier Carbon Burden because they have high levels of the Borough within Conservation such as: 52% (Bath), 50% (London Borough of Islington) or 78% (London Borough of Westminster). These Councils need to be more radical. At time of writing, 338 out of 409 UK councils have declared a climate emergency, and 270 of these have written a Net Zero Plan. 27 London Councils have declared Net Zero by 2030, only 8 years away.

Building Element Audits of: roofs, walls, and windows, which we have classed in this report as **third generational** can be used for: possible solar panels, external wall insulation, and double or triple glazing retrofits. This follows from current good practice of this proactive and finer grain analysis such as found with L. B. of Westminster's roof audit map (page 21).

This toolkit outlines three steps to use to analyse existing Conservation Areas, **plus a fourth step Action Plan**. It demonstrates how the toolkit could be used through a worked example, London Borough of Islington Conservation Area 13. Every Conservation Area will be different, typologies and elements need to be adjusted locally.

Step 1 - Designation, 1st generation.

Step 2 - Appraisal, 2nd generation.

Step 3 - Element Appraisals, 3rd generation.

Step 4 - Action Plan planning policy to implement.

This report does not replace individual 'Whole House Retrofit Plans', however, it aims to enable a transparent planning process with proactive local guidance, saving homeowners & planners work.

Findings

Islington CA13

The worked example shows many surprising opportunities for carbon reduction compatible with heritage.

22% of Buildings are Negative, Neutral, or Damaged Positive, with potential for deeper retrofit, such as new insulated façades which can reduce harm if designed to the heritage context .

44% of solid walls are suitable for wrapping the building mass with External Wall Insulation.

19% of Buildings are suitable for capping with new highly insulated additional floors or roofs.

31% of Roofs are suitable for Solar Panels.

75% of Buildings may be suitable for Double or Triple Glazed windows, which if added to the existing 14% double glazed would make double glazing total of 89% in CA-13!

LONDON COUNCILS' Retrofit Action Plan

London Councils is the local government association for Greater London, England representing all London's 32 borough councils and the City of London. Council Leaders meet 8 times per year to focus on representing borough interests to the GLA, London's public services and the Mayor. It also develops shared policy.

In 2019 the London Councils' Transport and Environment Committee (TEC) and the London Environment Directors' Network (LEDNet) agreed an ambitious Joint Statement on Climate Change as well as seven major programmes for cross-borough working¹. In 2020, Transport Environment Committee endorsed a lead borough or boroughs for each of these seven programmes who will be responsible for overseeing implementation of the action plan for each area:

The Retrofit London Housing Action Plan, July 2021, is part of Programme #1 Retrofit London; with lead boroughs LB Enfield and LB Waltham Forest.²

#1 Retrofit London

- #2 Low-carbon development (i.e. new buildings)
- #3 Halve petrol and diesel road journeys
- #4 Renewable power for London
- #5 Reduce consumption emissions
- #6 Build the green economy
- #7 Creating a resilient and green London.



¹ <https://www.londoncouncils.gov.uk/node/36794>

² <https://www.londoncouncils.gov.uk/our-key-themes/climate-change/retrofit-london-housing-action-plan>

This document is a very complete blue print for action with: technical details, case studies, recommendations. For planning it makes key recommendations summarised below.

Our document, Climate Emergency Conservation Area Toolkit, attempts to answer and give more detail from a planning perspective to these recommendations for Conservation Retrofit with data from an audited CA.

ACTION Point 9 (pages 78-80.) **Enhance planning to facilitate low carbon retrofit, including in conservation areas**

Key points summarised.

Positive action in planning

Permitted Development rights and local planning special guidance could be used to give more support to energy efficiency.

Environmental and heritage conservation hand in hand

The 'significant weight' placed on buildings with heritage value in the National Planning Policy Framework must be balanced with the 'public benefit' of energy efficiency improvements.

Clear guidance on what is possible

'Requiring planning' is seen as a significant barrier to retrofit.

Directly addressing heritage concern and value

Conservation area assessments do not mention retrofit or energy efficiency. Councils should clarify acceptable interventions in each conservation area, such as where external wall insulation is an acceptable approach, for example to the rear of properties, or to some stucco/rendered properties with certain conditions on detailing.

Provide a simple application process for key interventions

Some interventions for retrofit require a change to the external fabric of the building. Where this is known and is not covered by the planning system, London local authorities should seek to create standardised and simplified processes for applications.

Best practice is changing quickly

Building partnerships between departments within the council specifically on retrofit would be very beneficial.

Using the planning process as a positive opportunity

Consequential improvements required by the building regulations are often not considered or given sufficient weight. There is therefore a substantial opportunity for the planning process to influence positively the scope and ambition of projects involving retrofit.

Giving planning officers confidence and support

Disseminating existing guidance and case studies.
Training and events tailored to planning officers,
Bringing in external advice

1.0 Context : Introduction

1.1 Climate Emergency Declarations

We are living in unprecedented times with a warming planet which is bringing change to all of our activities including planning and conservation. Governments and councils have declared an intention to move to Net Zero quickly.

At time of writing, 338 out of 409 local, district, and county councils in the UK have declared climate emergency, and 271 of these 409 have a net zero plan. ¹ Just 57 councils with declared Net Zero Targets contain 1/3 of UK population. ²

In London, of the 32 Councils 27 have declared Net Zero carbon emissions on or before 2030 for their own estate or for entire borough. Inner London Boroughs with 50% or more of building stock within Conservation Areas will have difficulty meeting this commitment without climate emergency retrofits in Conservation Areas.

338 of 409

UK local, district and county councils declared climate emergency

27 of 32

London Boroughs declared Net Zero on or before 2030³

map www.londoncouncils.gov.uk



Key: net zero or carbon neutral by:



¹ <https://data.climateemergency.uk/councils/>

² <https://www.edie.net/news/6/One-third-of-UK-population-represented-by-local-authority-net-zero-commitments/>

³ <https://www.londoncouncils.gov.uk/our-key-themes/environment/climate-change>

1.2 Coverage Conservation Areas

There are nearly 10,000 unique Conservation Areas in England providing heritage protection for around 2.3% of England's land area or over 10% of properties.

The highest CA coverage areas are Isles of Scilly with 100% within conservation. Other high percentage areas are older heritage town centres such as Bath and London. The City of Bath is an important reference as it is a UNESCO World Heritage Site and understood to be a heritage city. The actual council is a large county council, Bath and North East Somerset with 35 Conservation Areas so we have analysed here just the City of Bath shown in purple within the green city borders to arrive at 52% land coverage. Outlying villages were not counted.

The first of Bath's conservation areas was designated in 1968, following the introduction of the Civic Amenities Act 1967. It was one of the first six to be designated in the country following the pioneering early Conservation Areas in the USA with New Orleans' Vieux Carré in 1925, followed by Charleston S. Carolina in 1930, Salem, Massachusetts in 1938, and Georgetown Washington DC in 1950.¹

London has 10.6% (1044) of all English Conservation Areas, with an average 17% land coverage across Greater London. Inner London Boroughs are much higher such as Westminster 78%, Kensington&Chelsea at 73%, Camden 50%, and Islington 50% (see opposite page). Although Hackney is 35% CA land coverage this is expected to dramatically grow with 12 new CAs proposed.

Approximately
10,000 unique
Conservation Areas
in England

10+%
of all Properties
in Conservation.



52%

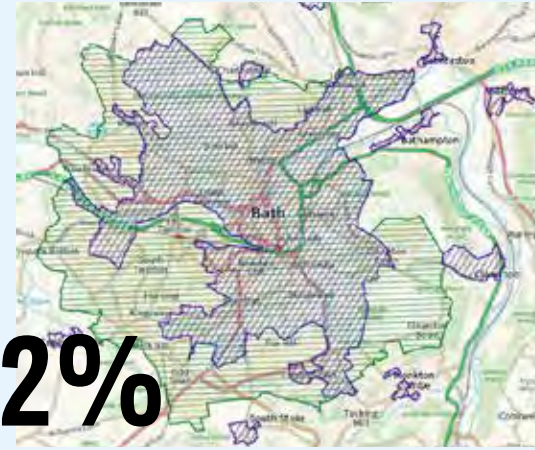

City of Bath
 Conservation Areas City Limits

17%

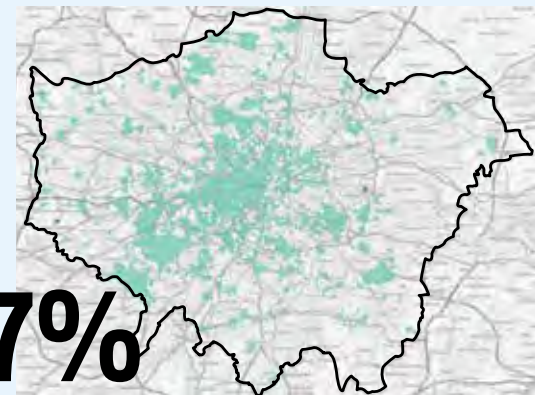

Greater London 10.6% of all English CAs (1044), 17% land coverage.
 Ordnance Survey open data, Open Government Lic.3.0 & GLA

+50%

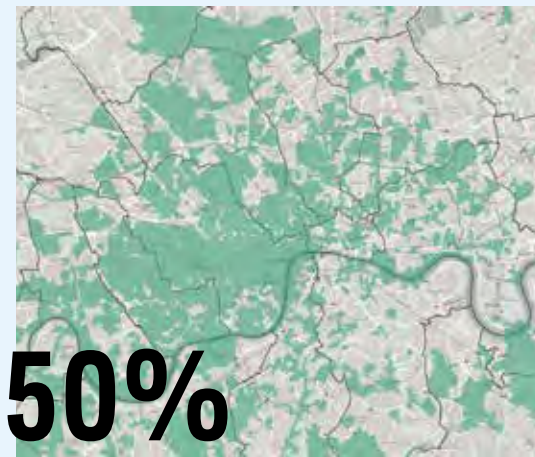

Inner London Considerably higher land Coverage
 Ordnance Survey open data, Open Government Lic.3.0 & GLA

Highest London CA Coverage

73%

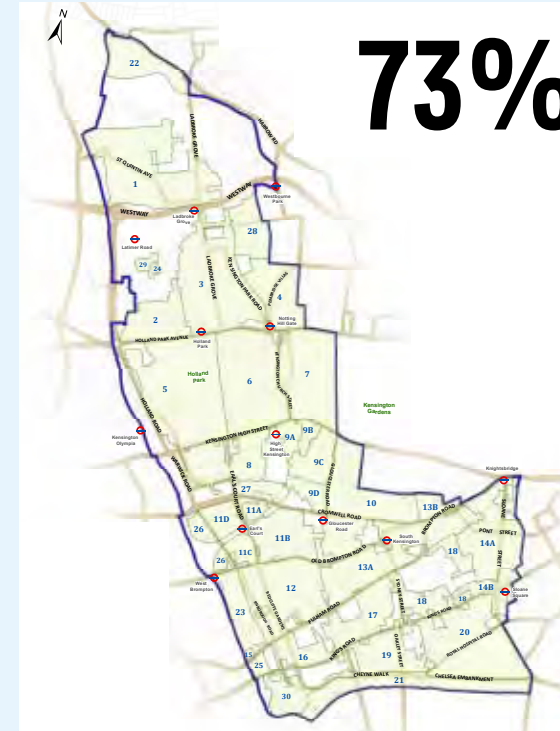

Kensington&Chelsea

<https://www.rbkc.gov.uk/leisure-and-culture/arts-and-culture/popular-local-maps> © Crown copyright and database rights 2014 Ordnance Survey 100021668

78%

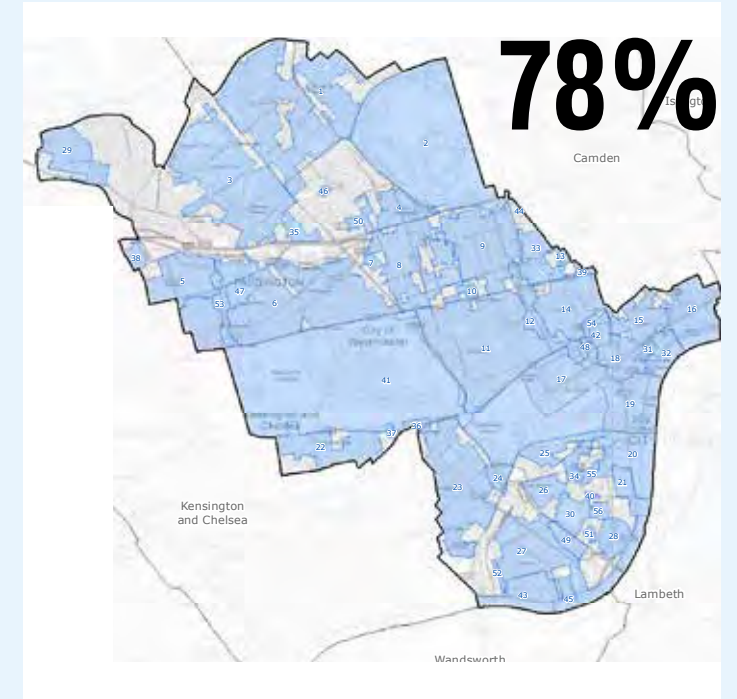

Westminster

<https://www.westminster.gov.uk/planning-building-and-environmental-regulations/design-and-heritage-planning/conservation-areas>
 Ordnance Survey data © Crown copyright and database right 2017

50%

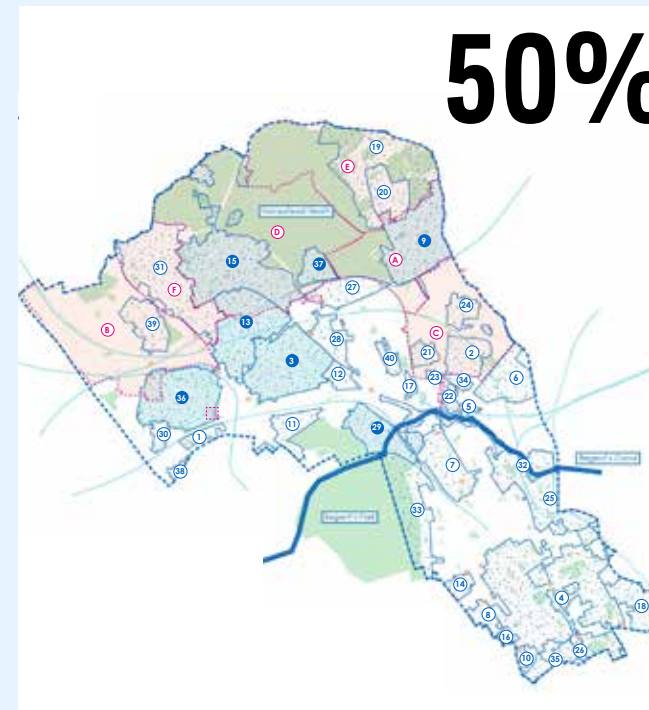

Camden

Map from document - HOME IMPROVEMENTS, Camden Planning Guidance, January 2021

50%¹

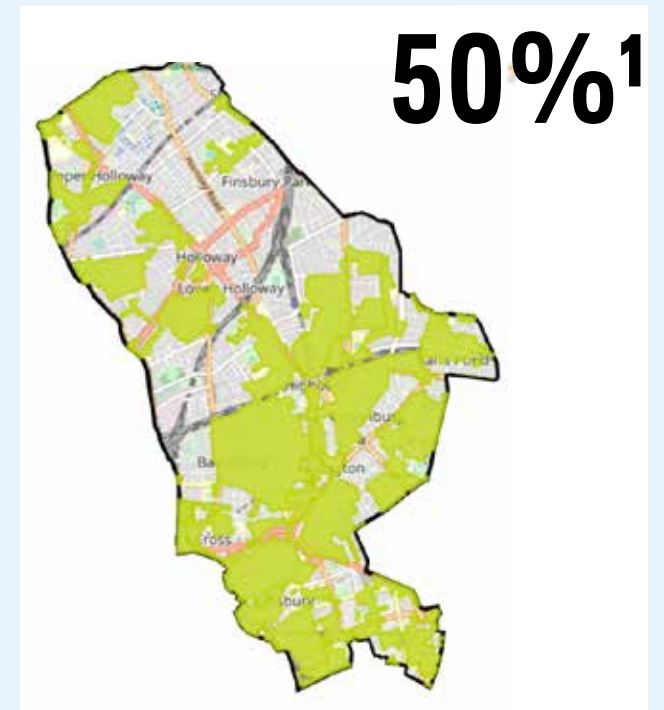

Islington

Islington Interactive Map, Conservation Area layers
<https://mapapp.islington.gov.uk/mapthatv3/Default.aspx>
 Copyright © 2018 CADLine Limited, Copyright © 2013 OS License 1000551221
¹ <https://www.islington.gov.uk/planning/designandconservation>

12 ¹ https://www.designingbuildings.co.uk/wiki/The_history_of_conservation_areas

1.3 Planning Policy

1.3.1 English Planning Policy 2021

Recent planning policy reinforces the public benefit of environmental objectives as well as heritage. The National Planning Policy Framework requires any harm to designated heritage assets to be weighed against the public benefits of the proposal. **Public benefits** may follow from many developments and could be anything that delivers economic, social or **environmental objectives**... ref. National Planning Policy Framework NPPF 2021

NPPF (National Planning Policy Framework) - Public Benefit of Sustainability

Red text here and throughout used by author for emphasis, not in original documents.



Excerpt from paragraphs 7-11, and 207 of the NPPF 2021 document

"7. The purpose of the planning system is to contribute to the achievement of sustainable development. At a very high level, the objective of sustainable development can be summarised as **meeting the needs of the present without compromising the ability of future generations to meet their own needs.**⁴

8.c) an environmental objective—to protect and enhance our natural, built and historic environment; including making effective use of land, improving biodiversity, using natural resources prudently, minimising waste and pollution, and mitigating and adapting to climate change, including moving to a low carbon economy.

9. These objectives should be delivered through the preparation and implementation of plans and the application of the policies in this Framework; they are not criteria against which every decision can or should be judged.

Planning policies and decisions should play an active role in guiding development towards sustainable solutions, but in doing so should take local circumstances into account, to reflect the character, needs and opportunities of each area.

11. **Plans and decisions should apply a presumption in favour of sustainable development."**

⁴ Resolution 42/187 of the United Nations General Assembly

"207. **Not all elements of a Conservation Area or World Heritage Site will necessarily contribute to its significance.** Loss of a building (or other element) which makes a positive contribution to the significance of the Conservation Area or World Heritage Site should be treated either as substantial harm under paragraph 201 or less than substantial harm under paragraph 202, as appropriate, taking into account the relative significance of the element affected and its contribution to the significance of the Conservation Area or World Heritage Site as a whole."

1.3.2 Local Authority Policies - Local Plans

Local Councils are writing climate Mitigation into Local Planning Policy. Islington talks about **Evolving Character Protection** in Heritage Areas to shift emphasis from traditional Heritage needs to Environmental needs of people (future survival). Islington's Local Plan advocates for a change in UK policy on External Wall Insulation. Royal Borough of Kensington & Chelsea's Local Plan acknowledges urgent action is needed to significantly reduce heat and energy.

London Borough of Islington Local Plan 2021-22 (red authors emphasis)



The Islington Local Plan section 8.3 states,

"Mitigate the impacts of climate change...**Islington's character may need to evolve in order to meet these needs.**"
..."As part of evolving character protection of **the historic environment must be reconciled with the environmental.. needs and aspirations of people.**"

L B of Islington NetZero 2030 Vision Plan (red authors emphasis)



Islington Net Zero 2030 Vision Plan page 54 more radically wants government to

"relax planning rules"... "making external wall insulation permitted development in all cases outside conservation areas".

R B of Kensington & Chelsea Local Plan 2019 (red authors emphasis)



Royal Borough Kensington & Chelsea Local Plan, Section 24.3 states,

24.3.1 **The Climate Change Act 2008 requires a reduction in CO₂ emissions of at least 34 per cent by 2020 and 100¹ percent by 2050,** against a 1990 baseline. Climate change is emerging as one of the major challenges and one of the biggest health threats of the twenty-first century. **The Council acknowledges that urgent action is required to limit temperature rises to 2°C above pre-industrial levels.** Global average temperatures have risen by nearly 0.8°C since the late nineteenth century, and have risen by about 0.2°C per decade over the past 25 years.

24.3.5 Environmental policy suggests that greenhouse gas emissions can be greatly reduced by **significantly reducing the amount of heat and energy we use in our buildings, through energy efficient design, materials and construction,**

24.3.14 **Historic England acknowledges the importance of making reasonable alterations to the existing building stock to mitigate climate change** and states that often the energy efficiency of the historic buildings can be increased in ways sympathetic to their historic character.

¹ Editor changed from eighty percent as this was written before 2019 amendment

1.4 TECHNICAL CONSERVATION PRACTICE

1.4.1 DESIGNATION - 1st Generation Legislation

Local Planning Authorities (LPA) have a duty under the Planning Act 1990 to designate Conservation Areas and review them from time to time. In practice, most Conservation Areas have not been reviewed since they were first formed. Many Conservation Areas are still based on original designations. This first generation of 'Conservation Area Design Guidelines' documents are most often only a border map with several pages of text referring to protection of heritage only. The worked case study, Islington CA-13 is one of these **First Generation** documents with a border map and 5 pages only.



London Borough of Islington

Cross Street CA13, Jan 2002, 5 pages

Planning Act 1990, CA Designation - LPA Obligations (red authors emphasis)

"Paragraph 69, **Designation of conservation areas.**

(2) It shall be the **duty of a local planning authority from time to time to review...**

Paragraph 71, Formulation and publication of proposals for preservation and enhancement of conservation areas.

(1) It **shall be the duty of a local planning authority from time to time to formulate and publish proposals** for the preservation and enhancement of any parts of their area which are conservation areas."

1.4.2 APPRAISAL- 2nd Generation Legislation

Detailed **Building Audit Mappings** were introduced by Historic England and the Government in 2019. This followed years of existing good practice with mapping of four classes of importance - Negative, Neutral, Positive, and Listed - by some authorities such as London Borough of Westminster from 2008 and Royal Borough of Kensington & Chelsea in 2015. These new appraisals with detailed negative/positive mapping more accurately define areas for beneficial change of heritage and non-heritage buildings within designated Conservation Areas.

Royal B of Kensington & Chelsea, THE BOLTONS CA, Feb 2015

Buildings Audit

2.15 The Buildings Audit Map shows the contribution made by buildings to the historic and architectural character of the area. For all buildings identified here as positive buildings, change must be managed to conserve and, where appropriate, enhance their significance in accordance with the historic environment policies.

Listed Buildings

2.16 A listed building is a building designated by the Government on the advice of English Heritage as a building of special architectural or historic interest. Great weight is given to their conservation.

Positive Buildings

2.17 These buildings make a positive contribution to the historic and architectural character and appearance of the conservation area. They are a key reason for the designation and significance of the conservation area. Demolition or unsympathetic alterations will normally be resisted.

Neutral Buildings

2.18 These buildings may blend into the townscape by virtue of their form, scale or materials, but due to their level of design quality, fail to make a positive contribution. Improvements to these buildings would be welcomed.

Negative Buildings

2.19 Negative buildings are those that are clearly harmful to the character of the area. Their removal and redevelopment would be welcomed subject to the highest quality design.

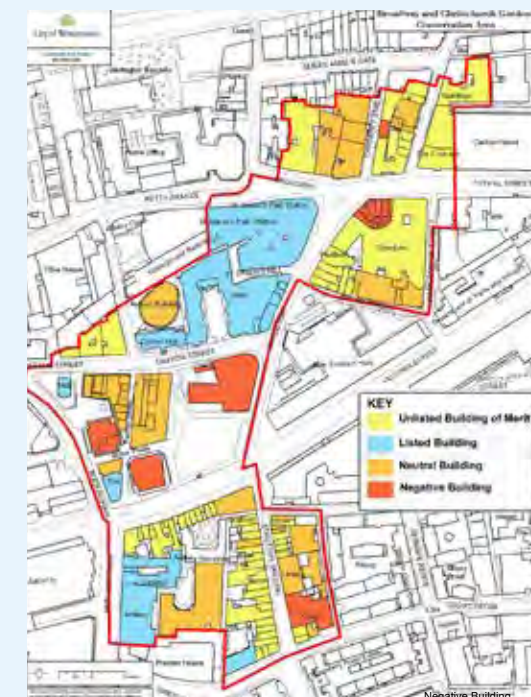

Building Audit LB of Westminster

Broadway & Christchurch Gardens CA, July 2008, 68 pages

PPG Planning Policy Guidance (23 July 2019) states, LPA Obligations

"Paragraph 025, A conservation area appraisal can be used to help local planning authorities develop a management plan and plan-making bodies to develop appropriate policies for local and neighbourhood plans.

A good appraisal will consider what **features make a positive or negative contribution** to the significance of the conservation area, thereby identifying opportunities for **beneficial change** or the need for planning protection."

Historic England 'Conservation Area Appraisal Designation & Management' (Feb 2019)

'More recent **good practice for Local Authorities** is to develop Appraisals and CA Management which **define both Positive and Negative contributions within Conservation Areas**. Development of detailed mapping required'.

TECHNICAL CONSERVATION PRACTICE

Here are four more examples of Conservation Area Building Audit mappings. London Borough of Westminster have an early example in 2008 on the previous page and the one below both using Negative, Neutral, Positive the previous page and Listed categories. London Borough of Hackney Brownswood CA, designated in 2020, also uses the 4 category system. The City of Bath and London Borough of Camden use slightly different classifications without Neutral. All of these are fully revised Appraisal Documents of many pages (see captions).



London B. of Westminster - HARLEY STREET CA, 16 June 2008, 129 pages



18 **London B. of Hackney** - BROWNSWOOD CA, 24 February 2020, 28 pages

1.4.2 continued APPRAISAL Building Audit Practice

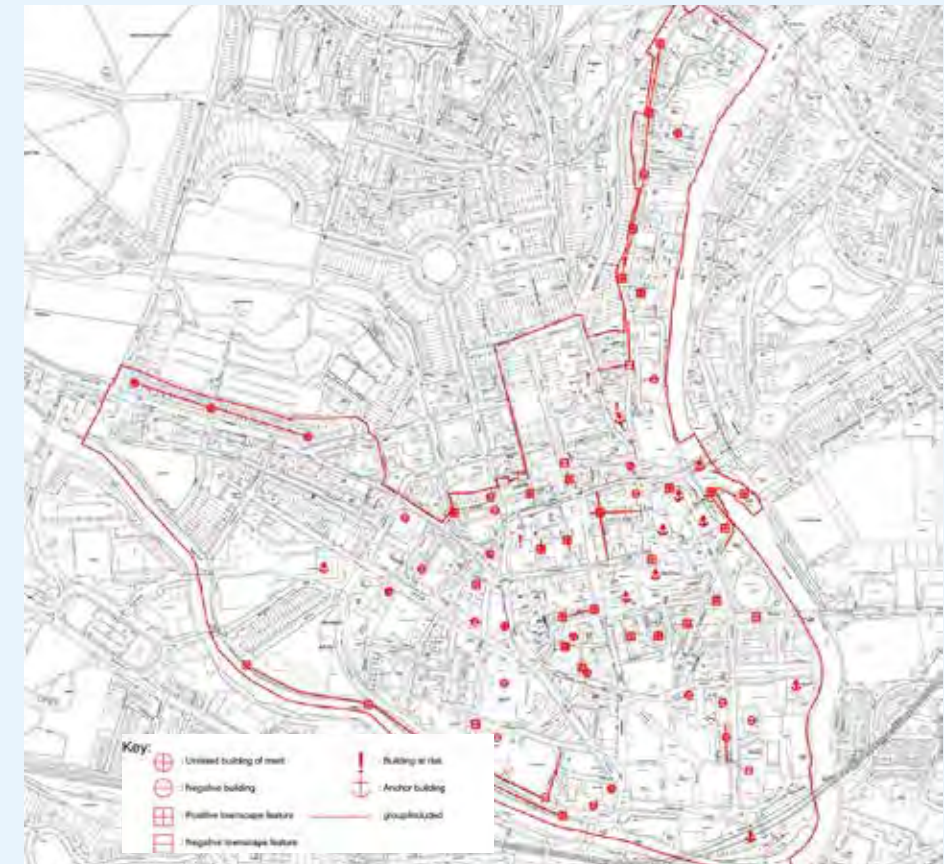

CITY CENTRE CA, Nov 2015, 56 pages, **City of Bath**
(same Positive/ Negative just different graphics)

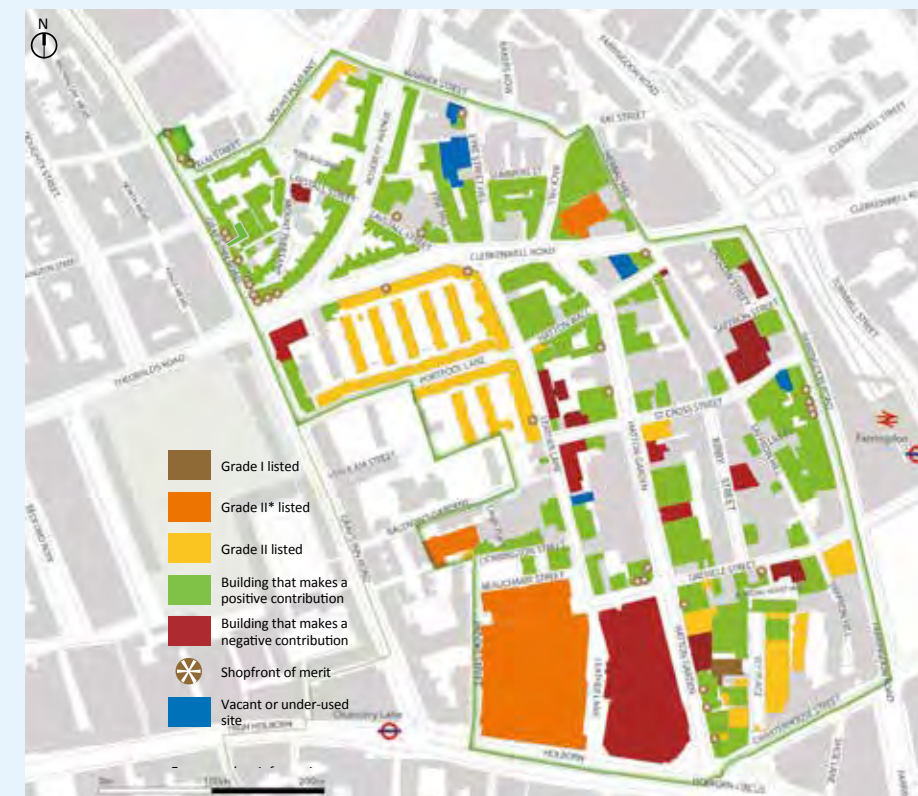

HATTON GARDENS CA, Aug 2017, 102 pages **London B of Camden** 19

1.4.3 TECHNICAL Detail Practice

Detail Appraisal -Characteristics Mapping for better area management

A few Councils have gone beyond Building Audit mapping to show a variety of other building and neighbourhood characteristics. As with the London Borough of Camden examples here, they build up greater and greater detailed modelling of these buildings and streetscapes. In the case of the Hatton Gardens Streetscape proposal map the mapping suggests possible design changes. This information aids in proactive policy as per England's PPG 2019 for **'beneficial change'** to improve the Heritage Area.

Detail mapping for L B of Camden -Hatton Gardens CA, Aug 2017, 102p

- Historic Land use, Past maps
- Period -Building Ages map
- Character Zones or Development Stages Estates map
- Building Use Classes, Commercial /residential map
- Views and Landmarks map
- Traffic Movements
- Height number of storeys
- Public Realm - Street Improvements/ planting



Age of Buildings Map



Land Use/ Retail Map



Number of Storeys Map



Streetscape Proposals Map

1.5 Element Appraisal

1.5.1 Building Elements- 3rd Generation

Some councils such as Redcar & Cleveland and LB Westminster in the examples below have started Building Element Audits. The Westminster example of Roof elements show negative extensions in red, existing heritage roofs in yellow and green (if listed), modern extensions in light blue, and suitable for new extensions in dark blue. This is a form of the Positive/ Negative audit that can inform policy for element retrofitting at the local level for parts of buildings. This is a natural extension of the system already in practice and can be very useful for windows, external walls, solar roofs etc. to define standards.

In Bath, a World Heritage city with 52% CA coverage, **element analysis** for both slimline double glazed windows and external insulation on Listed buildings was used by the Bath Preservation Trust. "Warmer Bath: A guide to improving the energy efficiency of traditional homes in the city of Bath", Will Anderson, Centre for Sustainable Energy and Joanna Robinson, Bath Preservation Trust, June 2011.

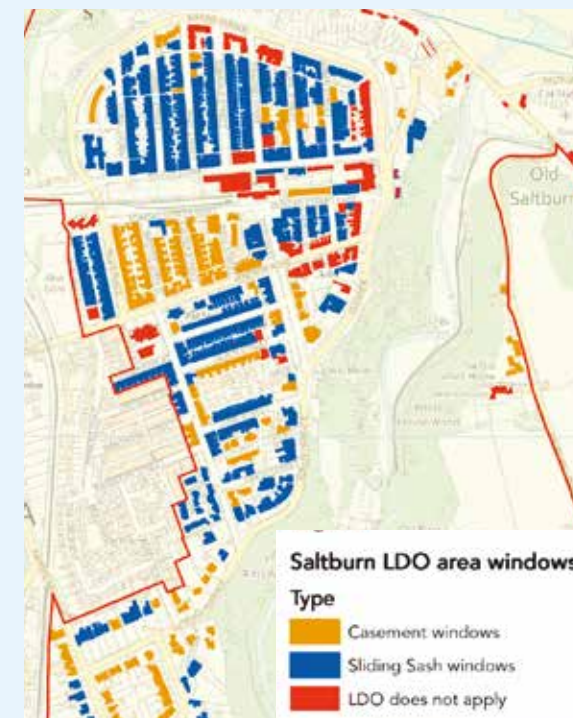

Redcar & Cleveland, Window Type Element Audit

Saltdean Conservation Area
LDO, 2021

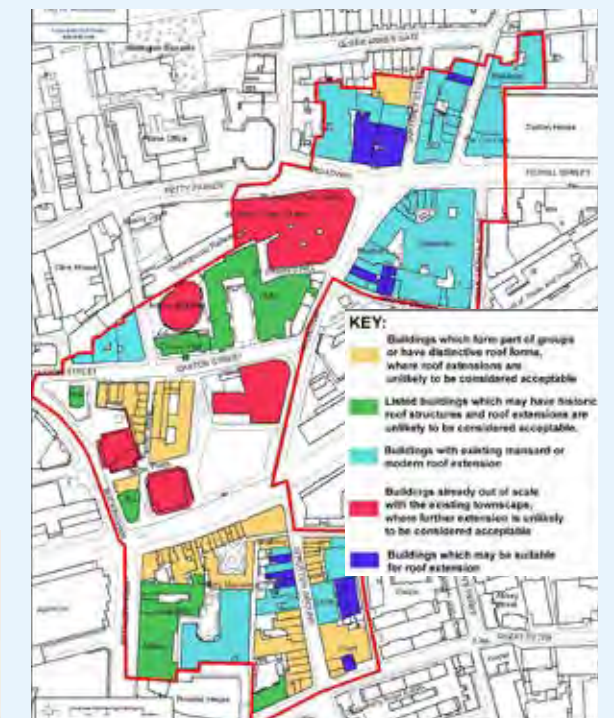

LB of Westminster, Roof Extension Element Audit

Broadway & Christchurch Gardens,
July 2008, 68 pages

2.0 Toolkit worked example

Toolkit Scope

This toolkit addresses only aspects of retrofitting heritage and non-heritage in Conservation Areas which involve planning. These are generally exterior building changes that impact the appearance of the Conservation Area. Internal measures not addressed are: loft, underfloor, internal wall insulation, or detailed equipment design of heat pumps which need reference to additional technical guidance. All measures both internal and external must be addressed by 'Whole House Retrofit Plans.'

British Standards Institute (BSI) PAS 2035 certification covers retrofit methodology which is mandatory since 30th June 2021. Retrofit Coordinators will develop a 'Whole House Retrofit Plan' that suits the particular house with fabric and mechanical equipment design recommendations. This plan can be implemented all at once such as during property extensions, or in stages. Identical houses in a terrace or neighbourhood can share one assessment report if all specific dwelling issues are identified. LETI is producing a 'Retrofit at scale: how many, how deep, at what cost', which outlines three levels of 'Whole House Retrofit Plans' which may be able to be customised further by Local Authorities or Region, see LETI publication page for upcoming 2023 release.¹

All Conservation Areas are different, e.g. the Alexandra Road Estate CA in the London Borough of Camden is a listed 1970s estate which will have different concerns from the ones of the worked example. This document promotes a strategy for assessing and recommending area measures to be adapted locally.

¹ <https://www.leti.uk/publications>

Toolkit Structure

STEP 1 Designation - Existing Guidance & Map

Review First Generation, Local Current Guidance Documents
Is there an Article 4 Directive applied?

STEP 2 Appraisal - Buildings Audit

Review Second Generation, Appraisal Building Audit or, Conduct a new Building Audit if missing or old, with new mapping/photos of -Listed, Positive, Neutral, Negative

STEP 3 Appraisal - Building Elements Audit

Conduct New Third Generation Detailed Element Audit Mapping. Determine local typologies and suitable local elements for appraisal of heritage and retrofit using individual element positive/negative mapping. Some councils have started this. Quantify data and building address recommendation lists.

As discussed in the previous section, good conservation practice has been evolving from designation, to review/ appraisal, and finally to detailed element appraisals. We see this development as **3 generational steps** which have evolved from good practice and legislation.

The new Step 3 Element analysis must be formatted to include useful components to allow Climate Emergency retrofit of some buildings or parts of buildings within Conservation Areas. Element analysis such as: windows, walls, roofs, chimneys, parapets, porches, and renewable tech are universal for all Conservation Areas but there may be additional unique components such as Shopfronts.

Some changes to such external elements are Permitted Developments that do not normally need planning permission. To remove this national right and require planning permission, the Local Authority would need the approval of the Secretary of State for suitable Article 4 Directions removing the Permitted Development rights. If the rights were not removed by Article 4 Directions, the Local Authority could still show best practice; for instance, when replacing windows it could use timber with suitable double and triple glazing.

Worked Example

Originally we planned to work through three examples, London, Bath and a northern or rural Conservation Area to develop and show application of principles. This would have made the exercise too large for a volunteer-led unfunded research project.

The London Borough of Islington CA13 example was chosen due to its familiarity to the researchers, small size and amount of heritage. With only 173 individual buildings it is small enough to easily quantify data obtained. It has 54 listed Georgian buildings, close to 1/3 of total. It also has some fine Victorian terraces & blocks, modern houses, and social housing. This variety of building types tests the research proposal. In just its roofscape (13 found), it contains most types of urban roof typologies. Being in the dense urban area of central London it represents Local Authorities with high amounts of Heritage, (Islington has 50% as shown in the preceding introduction).



LB of Islington, Cross Street CA13, Guidance Document Jan 2002, 5 pages only

2.1 Designation -Existing Conditions

Existing Map of LB Islington CA13

Statutory requirement of local planning authorities to continually reappraise Conservation Areas.

'designation might be needed for areas along the borders of a conservation area which would benefit from designation.'

Conservation Area Appraisal, Designation and Management Historic England Advice Note 1 (Second Edition) pages 6-7

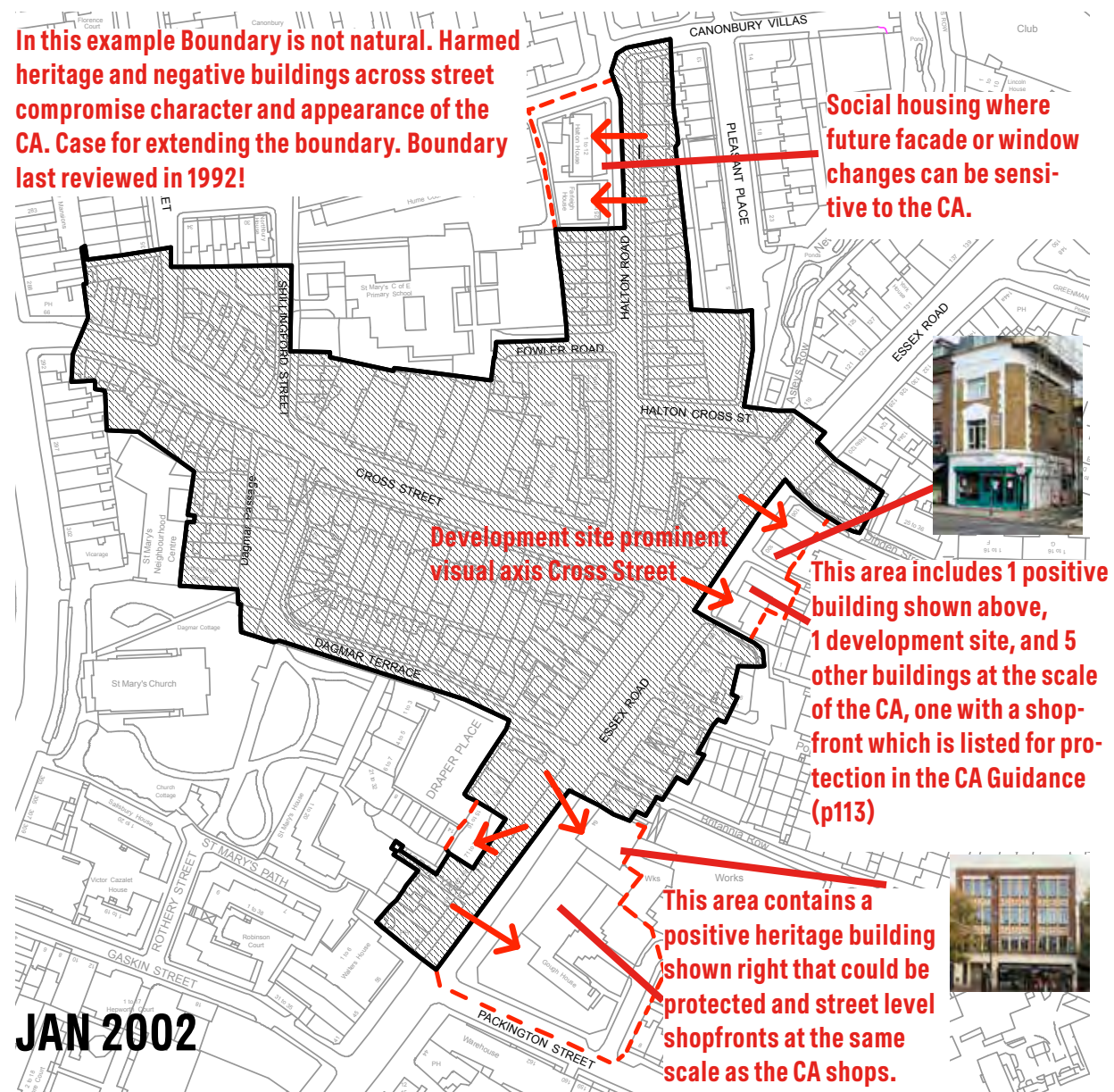

Toolkit -STEP 1

FINDINGS Islington CA13

Public Realm Audit

The current Conservation Area Boundary needs to be reviewed as it is not a natural boundary. Exclusion of one side of the street in 4 places creates a conflict to the character and appearance of the Conservation Area as the public realm is not a consistent unified space. Several positive buildings and shopfronts in these excluded zones have started some improvement, one of which is protected by the CA13 document although it is in the excluded zone. The last time the boundary was amended was in 12/03/1992 (30 years ago).

Two sites are potential redevelopment for much needed additional housing. The single storey 6 shop parade corner of Cross and Essex, and the empty lot at 90-92 Essex Road would benefit heritage street heights by matching building heights with 4 storey buildings.

London Borough of Islington's Cross Street CA13 was established in 28/07/1970, only 3 years after the introduction of the Civic Amenities Act 1967. It was one of the early designations in the country.

The current Guidance Document of only 5 pages is more than 20 years old dating from 2002. The approach taken is a written listing of protection of some buildings and some townscape features without any illustrations or mappings. It does not specify negative features that, if improved, would benefit the Conservation Area.

The boundary was last amended in 12/03/1992 (30 years ago). The current Conservation Area is not a natural neighbourhood because the zig-zag boundary excludes opposite sides of the street. Historic England Conservation Area Appraisal, page 26 advises, **'avoid for example running along the middle of a street.'**

A particular oddity in the document is a shopfront in one of these excluded zones is listed for protection although it is not part of the Conservation Area. Two positive buildings (see images on map) in excluded zones would benefit from protection. There is a clear case for extending the boundary since its last review in 1992.

This Conservation Area has an Article 4 Direction removing national Permitted Development rights with the effect that even minor alterations need planning permission.



Listed Georgian terraces - Cross Street

Planning Act 1990, CA Designation - LPA Obligations (red indicate authors emphasis)

"paragraph 69, **Designation of conservation areas.**

(2) It shall be the **duty of a local planning authority from time to time to review...**

paragraph 71, Formulation and publication of proposals for preservation and enhancement of conservation areas.

(1) It **shall be the duty of a local planning authority from time to time to formulate and publish proposals** for the preservation and **enhancement** of any parts of their area which are conservation areas."

2.2 Building Audit Appraisal

A few English councils have carried out Building Audits, shown in section 1.4.2 as part of new Appraisals. This system promoted by Historic England allows a more tailored approach to heritage amenity within Conservation Areas but also allows public environmental amenity to be assessed. In this example the study has assessed the 4 categories, with standard practice colours used in the colour coding. Each category is individually mapped and buildings photographed. See appendices pages 129-137.

173 buildings

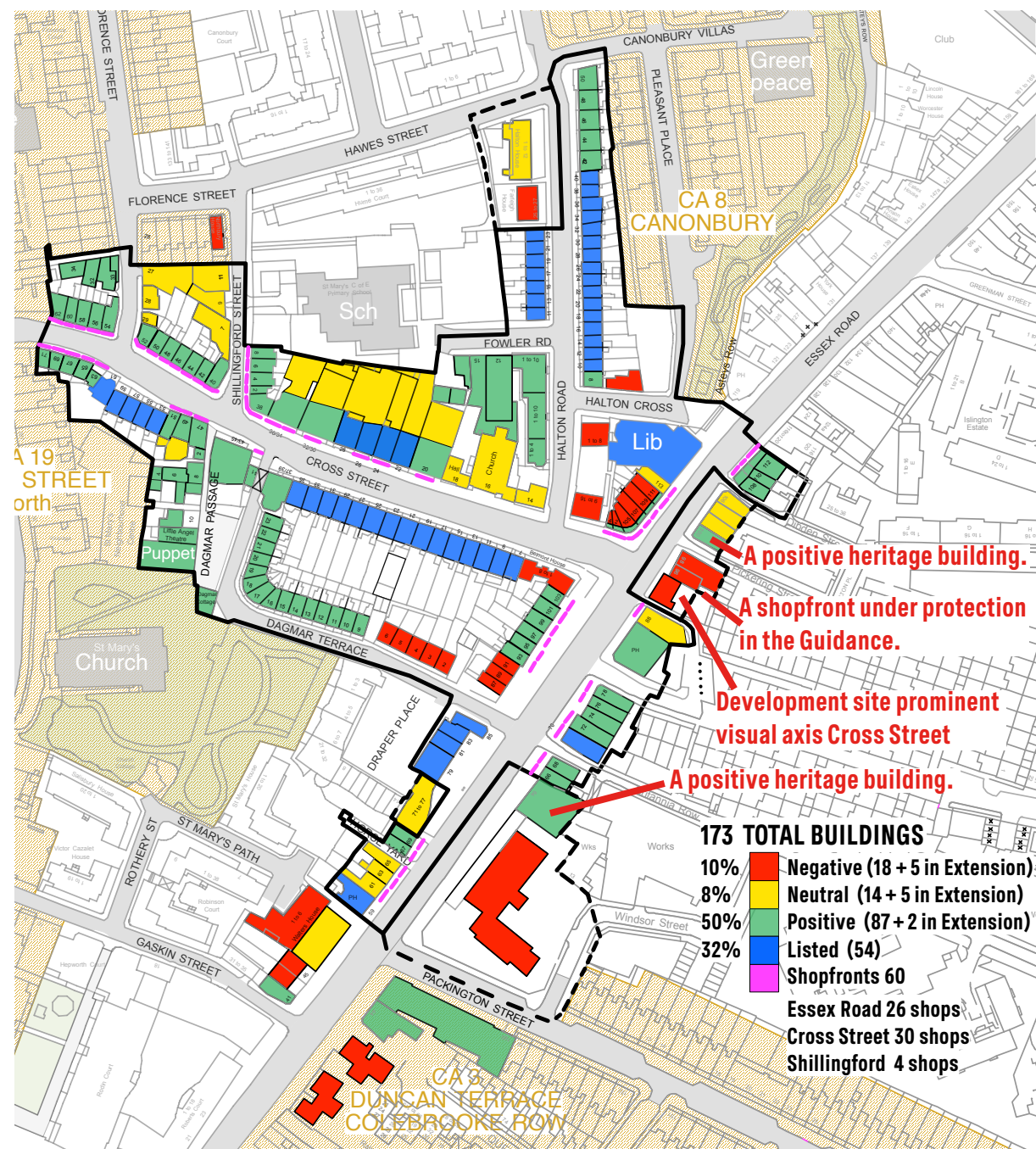

Toolkit -STEP 2

This Conservation Area is a primarily residential Conservation Area with only 10 non-residential buildings; 2 pubs, a library, a nursery school, a theatre, and a church with auxiliary buildings. Although it has 60 shops in ground and lower ground floors the premises above are generally residential.

An audit map of all Listed, Positive, Neutral and Negative buildings was performed as CA13 as it hasn't undergone a Government and Historic England recommended positive/negative Building Audit, as per PPG 23 July 2019 below. This audit does not include Locally Listing Buildings, or part of buildings, of which there are 45. This local list is out of date with the newest description 29 years old going back to 44 years for some. Most of the local list fall into Positive category buildings. The newer positive /negative Building Audit more accurately assesses these buildings. See appendices 129-137.

FINDINGS Islington CA13

Building Audits

Current UK Planning Appraisals and Historic England call for Negative, Neutral, Positive, and Listed Audits. Although it has six historic terraces making up the bulk of the listed houses, it does, surprisingly, have 22% harmed, neutral and negative buildings within it.

22% of Buildings, are Negative, Neutral, or Harmed Positive, (remaining 78% of buildings are positive or listed).

82% of Shopfronts are Harmed. (only 18% of shopfronts are original or reconstructed heritage).

163 residential (of 173) buildings

173 buildings

18 Negative buildings
14 Neutral buildings
87 Positive buildings
54 Listed buildings

60 shopfronts

22 Negative Shopfronts
27 Positive some harm
11 Unharmed Exemplar

from Shopfront Audit pages 138-145

PPG Planning Policy Guidance (23 July 2019) states, LPA Obligations (red indicate authors emphasis)

“Paragraph 025, A conservation area appraisal can be used to help local planning authorities develop a management plan and plan-making bodies to develop appropriate policies for local and neighbourhood plans.

A good appraisal will consider what features make a positive or negative contribution to the significance of the conservation area, thereby identifying opportunities for beneficial change or the need for planning protection.”

2.3 Element Audit Appraisal

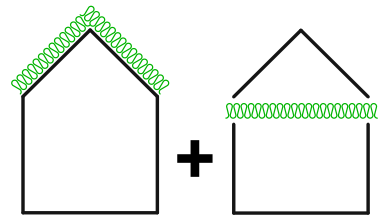

2.3.1 Roof Extensions, Woolly Caps & Scarves
Roof Insulation & Cold Bridge Junction Strategy
Roof or additional storey extension

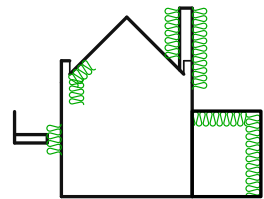

2.3.2 Projecting Features, Ear Muffs
Compact Form & Cold Bridge Strategies
Garden extensions, chimneys, parapets, balconies

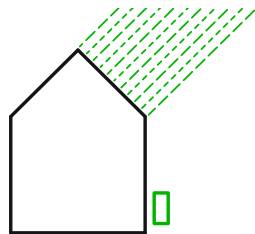

2.3.3 Renewables, Bask in the Sun
Solar & Heat Pump Strategy
Solar panel and heat pump layout and location

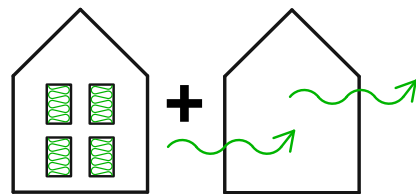

2.3.4 Windows, Eyeglasses
Double or Triple Windows with Ventilation Strategy
Replacement windows

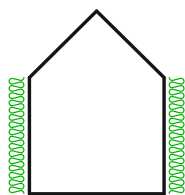

2.3.5 Walls, Woolly Jumpers
External Insulation vs Internal Insulation Strategy
Public/private realm wall insulation

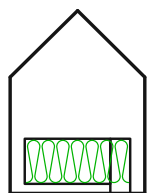

2.3.6 Shopfronts, Leg warmers
Particular local types - Shopfront Window/Door Strategy
Double glazed shopfront windows

Detailed analysis of each Element on following pages 32-127

Toolkit -STEP 3

163 of the 173 buildings are residential, although some of these are mixed residential with shopfronts on the ground floor. This study focuses on this majority (residential and the mixed use residential/shopfronts) as they all have common building elements. The 10 other buildings would be determined on a case by case basis.

Six element types plus two (complementary) were identified as: roofs (+cold bridge junction), projecting elements, solar, windows (+ventilation), walls and shopfronts. The first five would be universal across all Conservation Areas as they are common features. Planning considerations may be needed for the two complementary aspects: coldbridge roof junctions due to parapet redesign or eave extension, and ventilation due to window upgrades which require visible facade airbricks/grilles or window trickle vents.

The Toolkit process is an audit stock take of each element with detailed mapping and photographic survey of variations of type. Current planning guidance for beneficial change of this element was then studied with changes recommended along with Building Reg 2021 for impact on the current planning policy. Some elements have city or national resource data that can be used such as the Solar Opportunity map data for London.

A clear definition of planning principles relevant to each element is required, therefore this study sets out definitions for meanings of the Public Realm, Significance, and Roof Heights.

The toolkit encourages the collection of detailed sample technical drawings and manufacturer lists to complement audit research. Details are very helpful as previous planning diagrams are unclear and often not aligned to other regulation. This precision will result in streamlining future planning for homeowners and planners necessary for a more rapid roll-out of retrofit for the climate emergency.

London Borough of Islington Local Plan 2021-22 (red authors emphasis)

The Islington Local Plan section 8.3 states,

“Mitigate the impacts of climate change...**Islington’s character may need to evolve in order to meet these needs.**”

...“As part of evolving character protection of **the historic environment must be reconciled with the environmental.. needs and aspirations of people.**”

FINDINGS LB Islington CA13

19% of Buildings are suitable for capping with new highly insulated additional floors or roofs.

12% of Buildings are suitable for roof extensions without chimney projecting features.

31% of Roofs are suitable for Solar Panels.

75% of Buildings may be suitable for Double or Triple Glazed window replacements.

44% of solid walls are suitable for wrapping the building mass with External Wall Insulation.

100% of shopfronts are suitable for double glazed shop facade windows.

2.4 ACTION PLAN

Existing planning procedures are too slow for the climate emergency. L B of Islington has enacted Article 4 Directions in many of its CAs which puts development through an under-funded planning system. **Currently with approx. 4000 planning applications per year, if all conservation homes would apply for planning over the next 8 years (to 2030) there might be an additional 4000 applications/ year, an unrealistic doubling of the system, not counting increases in other building applications.** Short of rescinding Article 4 Directions to allow permitted development on unlisted homes, councils can define development by rewriting individual CA Article 4 Directions and Guidance Docs. Alternatively a quick, efficient method may be using Consent Orders, to target change borough-wide as RBKC is doing^{3&4}.

DEFINITIONS Planning Tools

1 'Planning Permission' Local Authority grants an application for development. Planning permission is needed for any building work that falls within the legal definition of 'development'. Works which 'materially affect the external appearance of the building'. This excludes 'like for like' or repairs except in the case of Listed Buildings which need listed building consent for all works.

2 'Listed Building Consent' Local Authority grants application for works to a Listed building.

3 'Permitted Development' National Grant of automatic planning permission. Householder (dwelling house but not flats) permitted development for minor works such as window or door replacement as long as they are of 'similar visual appearance'.

4 'Article 4 Direction' This will remove permitted development rights within part or whole of the Conservation Area. Article 4 of the Town and Country Planning (General Permitted Development) (England) Order 2015. Approximately 15% of all English Conservation Areas are under Article 4 Directions. Of all Article 4 Directions approx. 74% are blanket with 26% specific buildings only.¹

5 'Listed Building Heritage Partnership Agreement' This is an Agreement between a local planning authority and the owner(s) of a listed building or group of listed buildings which grants listed building consent. It allows the local planning authority to grant listed building consent for the duration of the Agreement for specified works of alteration or extension (but not demolition).

These remove the need for the owner(s) concerned to submit repetitive applications for listed building consent for works covered by an Agreement.

6 'Local Listed Building Consent Order' LLBCOs are made by local planning authorities and grant listed building consent for works of any description for the alteration or extension (but not demolition) of listed buildings in their area, Planning Act 1990. This means that owners and developers do not need to submit repetitive applications for listed building consent for works covered by an Order. **The Royal Borough of Kensington & Chelsea was the first in the country in March 2022 to issue Consent Orders for Solar Panels³ on Grade II and II* properties and now, November 2022, the borough is intending double glazed windows.⁴ Port Sunlight issued a Consent Order in 2015 for double glazed windows on rear facades LLBCO 2015.⁵**

7 'Local Development Consent Orders' LDO from 2004. NPPF 2021 paragraph 51, 'Local planning authorities are encouraged to use Local Development Orders to set the planning framework for particular areas or categories of development where the impacts would be acceptable, and in particular where this would promote economic, **social or environmental gains** for the area.'² These can provide the counterpart of LLBCOs of best practice for unlisted buildings in both Conservation Areas and borough-wide.

8 'Neighbourhood Development Order' & 'Community Right to Build Order' developed by Neighbourhood Forums which modify the Local Plan through a local referendum. NPPF 2021 paragraph 52, 'Local planning authorities should take a proactive and positive approach to such proposals, working collaboratively with community organisations to resolve any issues before draft orders are submitted for examination'.²

¹ Survey commissioned for the English Historic Towns Forum, <https://www.htvf.org>

² <https://www.gov.uk/government/publications/national-planning-policy-framework--2>

Toolkit -STEP 4

Step 4 Toolkit, review Local Authority Local Plan and document production schedule.

LB Islington - Indicative Timetable for Documents (Sept 2021)

SPD-New NetZero Carbon New, Summer 2022 draft - final Late 2022. **Dates not met.**

SPD-Environmental Design, Oct 2012, to be replaced by Local Plan and New NetZero SPD

SPD-Urban Design Guide, Jan 2017, **Inaccurate, see p 46,48,61. Needs to be updated.**

Conservation Area Design Guidelines, No dates, **Most are 2002 (20 years old) so need revision!**

Local Development Consent Orders & LLBCO No dates, **Develop Orders borough-wide**



2019 Guidance LDO

<https://www.local.gov.uk/sites/default/files/documents/LDO%20Guidance%20Document%20March%202019.pdf>



2015 Guidance LLBCO

<https://historicengland.org.uk/images-books/publications/drawing-up-local-listed-building-consent-order-advice-note-6/heag009-listed-building-consent-order-an6/>

³ <https://www.local.gov.uk/case-studies/royal-borough-kensington-and-chelsea-local-listed-building-consent-order>

⁴ <https://www.rbkc.gov.uk/newsroom/pioneering-policy-could-mean-warmer-greener-listed-homes>

⁵ <https://www.wirral.gov.uk/planning-and-building/planning-permission/port-sunlight-local-listed-building-consent-order>

RECOMMENDATIONS England

Local Development Orders & LLBCOs

Immediately start developing these orders, to reduce the circumstances in which developments need planning permission for both unlisted and listed buildings. Separately these can be written for Solar, External Wall Insulation, Window replacement, Chimneys, Parapet walls, and other measures. See LLBCO 2022 RBK&C (solar² and windows)³, and LLBCO 2015 Port Sunlight, (windows, doors & gates).⁴

SPD- Net Zero & Urban Design Guides

to be written as detailed Pattern Books to supplement CA Guides using experts and community group input. These to go beyond current SPD with complete house typology solutions, detailed technical drawings and manufacturers' lists. These may change over time but should be regularly updated for best contemporary practice of retrofit and heritage construction. Details are very helpful as previous planning diagrams are unclear and often not aligned to other regulation. This precision will result in streamlining future planning for homeowners and planners necessary for a more rapid roll-out of retrofit to NetZero.

Conservation Area Appraisals

All Conservation Area Documents to be progressively updated with new Appraisal Management Plans with Building and Element Audits as per this toolkit. (for Islington - Cross Street CA13 to be updated immediately with this study data as a test case, see appendices page 157 for CA13 Draft Document).

2.5 Detailed Element Audits

Element Audits Toolkit Step 3

Mapping of Conservation Area

Photographic Surveys of Typologies

Current Guidance with Proposed Guidance

Supplementary Planning Document- Borough-wide

Applicable Principles

Current Guidance with Proposed Guidance

Complementary Technical Details

Producing Element data for at least one CA within the Borough will for data to aid in formulation of new;

Supplementary Planning Documents ,
Local Development Consent Orders, and
Conservation Area Appraisal Management Plans.

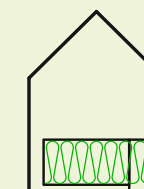
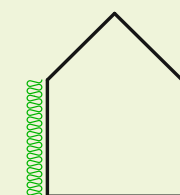
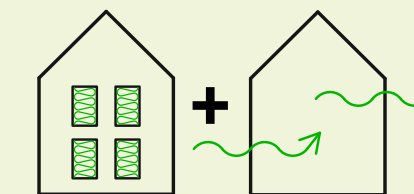
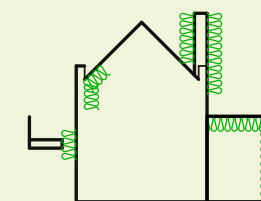
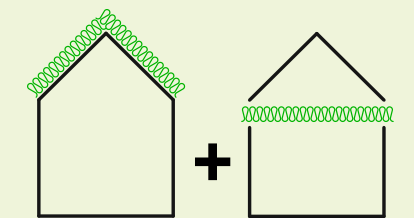

2.5.1 Roof Extensions

'Put on a woolly hat.'

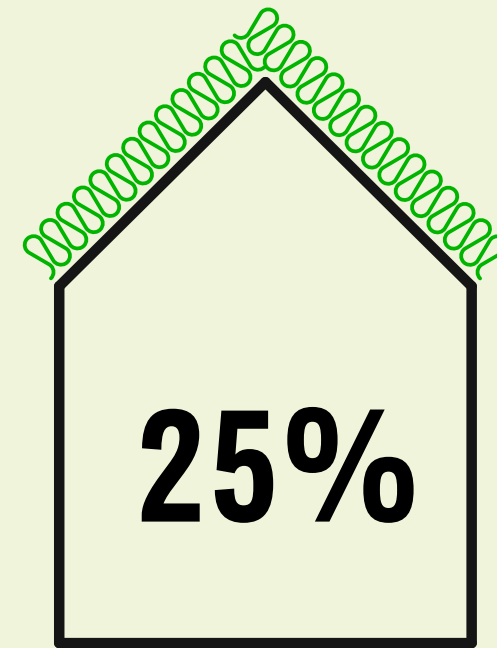

roof heat loss as a percent of total house¹

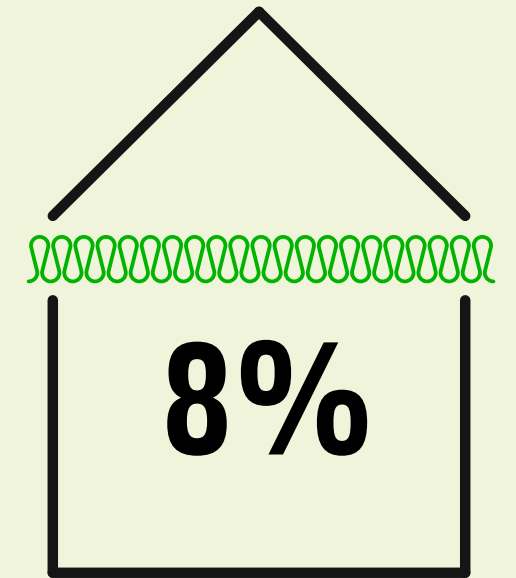

cold bridge loss where structure penetrates insulation as a percent of total house
these are often found where roof meets walls

¹ <https://www.rbkc.gov.uk/environment/climate-change/prevent-heat-loss-your-home>

AUDIT Roof Extensions mapping

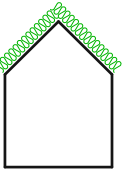

49%
of roofs are new, or
will be suited to change

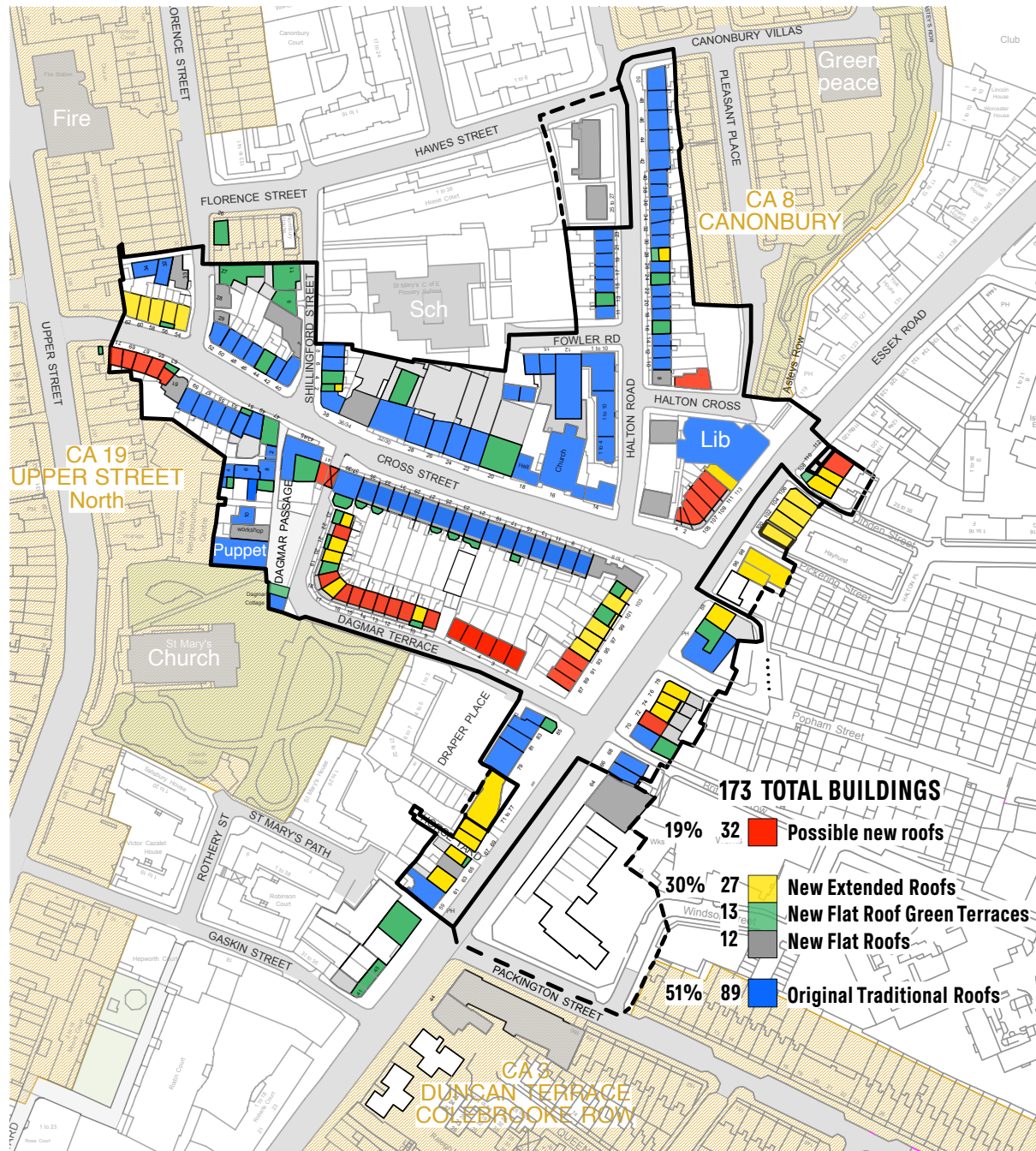

Roof Audit - ACAN worked example London Borough of Islington CA13

The roofs in this conservation area are very mixed. A large percentage, **38%** (66) are new flat (heritage roof removed), new mansards, or modern flat roofs. Some of these flat roofs (14) are suitable for roof extension. A further **11%** (18) of pitched are suitable for extended roofs.

Although 7% (13) of the buildings have a full flat green roof terraces as the predominant surface, 22% (38) of all buildings have full or partial flat green roof terraces. This shows there is a contemporary need in a dense urban environment for outdoor space which was not part of the original design of these Georgian and Victorian buildings. Planning today must acknowledge energy requirements and good roof details in visual guidance. There needs to be a new joined up thinking in the planning system between aesthetics/history, and technical/climate details that were not understood 20 years ago.



Imagery ©Google 2022, © BlueSky,CNES/Airbus,Getmapping plc,Infoterra Ltd&-Bluesky,Maxar Technologies

49%
Flat roofs, extensions, and
suitable for extension

51%
original traditional roofs
that should remain

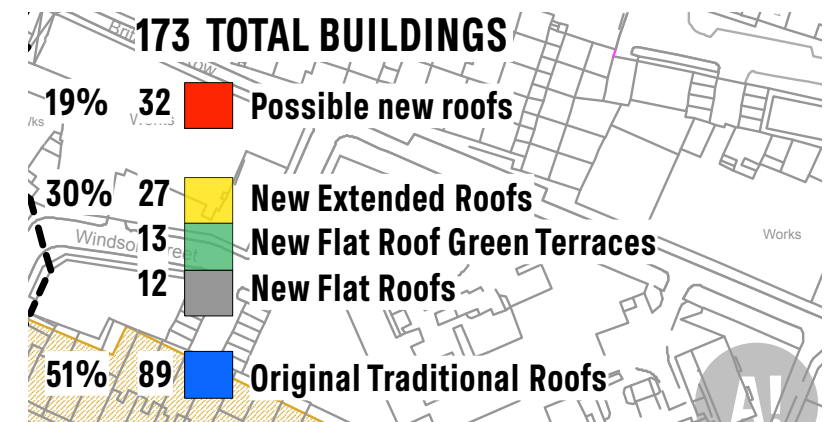

AUDIT Local Roof Types -Traditional



M pantiled roof. Ridge perpendicular to facade

81, 83 Essex Road -Listed

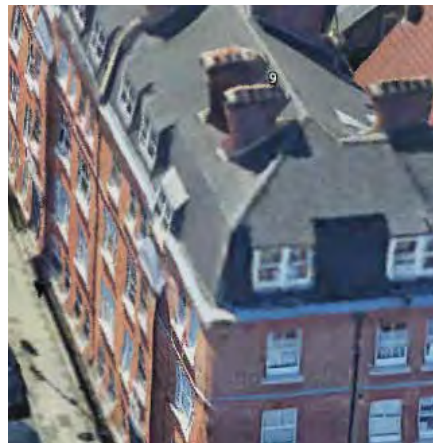

Mansard Slate roof. Only 8 Buildings of 173 are mansard

Halton Road



Single Ridge shallow Slate Ridge runs parallel to facade

41 Cross Street



Double Ridge pantiled roof. Ridge parallel to facade

55,57,59 Cross Street -Listed



Inverted Pitch roof known as London or Butterfly roof. With V Parapet rear.

16, 18, 20 Halton Road -Listed



Inverted Pitch- Rear Hip roof. High front parapet, rear no parapet.

46, 48, 50 Cross Street not listed



Inverted Pitch- Hip roof. Low front and rear parapets. Roof visible.

19,21,23 Halton Road -Listed 49 Cross Street, not listed



Local Roof Types -Flat & Extended AUDIT



Modern Membrane Flat roofs.



Modern Membrane Flat roof, new floor added to a Listed Building. 61 Cross St



Modern Flat Roof Listed Double Pitch roof infills. Cross Street



Contemporary Lightweight Roof Pavilions set back slim roof design -low insulation. Dagmar Terrace



Modern Mansards Low pitch. Cross Street



Modern Flat Roof Garden Terraces -12 in the CA



Old Asphalt Flat roof, **Harmed Heritage** Chimneys & inverted hip roofs removed. Cross Street



AUDIT Current Guidance (2002)

The current CA Guidance was made 20 years ago without a complete understanding of the existing roofs of CA13. This was prior to aerial photography available today through drones and web services such as Google maps. The analysis was carried out from street level which did not allow a full understanding of the state of the roofs.

The 2002 Guidance suggests roof extension might be allowed which would most likely damage the heritage double pitched roofs 55, 57 and 59 because at street level they are lower than no 53. This appears to be a visual aesthetic judgement rather than a heritage based one for these listed buildings.

The 2002 Guidance suggests roof extension might be allowed for 23 Cross Street which seems to be raising its height slightly and filling in the central V of the heritage double pitch roof like has been done to listed neighbours at numbers 13, 21, 27, & 29. Is that perhaps because changes to listed heritage are not visible at street level? The guidance intention is not clear.

Numbers 41 Cross Street, 76, 74, 72 Essex Road, and 8 Halton Road are not listed buildings so can be extended (as already done for 76 and 74), although today's energy regulation standards would mean that the slim roofs and low height would not likely be acceptable for no 72. No 8 Halton is a non-listed reconstructed Georgian that was built with a modern flat roof. A garden terrace or a solar roof would be more appropriate than an extension taller than the listed terrace. At the time the Guidance was written 20 years ago there was less understanding and acceptance of the need for garden roof terraces. CA13 has many garden roof terraces today and there is also a real need for solar.

Cross Street (CA13) Conservation Area Design Guidelines

January 2002

13.23 The Council may permit traditional roof extensions on the properties listed below; otherwise no roof extension visible from any street level position or public area will be permitted.

Cross Street: 23, 41, 55, 57, 59

Essex Road: 72, 74, 76

Halton Road: 8

Notwithstanding the above schedule, the Council will take into consideration the listed status of any of the above properties when considering appropriate extensions. Special regard must be paid to the retention of historic fabric where it exists and any extension which might be acceptable in townscape terms will still require careful and detailed examination.

9 Permitted Roof Extensions- 2002

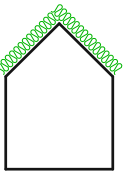

CROSS STREET

The five permitted extensions are: 41 Cross a non-listed single pitch roof between two higher ones, 23 Cross in a listed terrace where at least four houses have Georgian double pitch roofs filled in, and 55-59 Cross with double pitch roofs lower than No 53. This needs amendment as original listed roofs should not be removed.

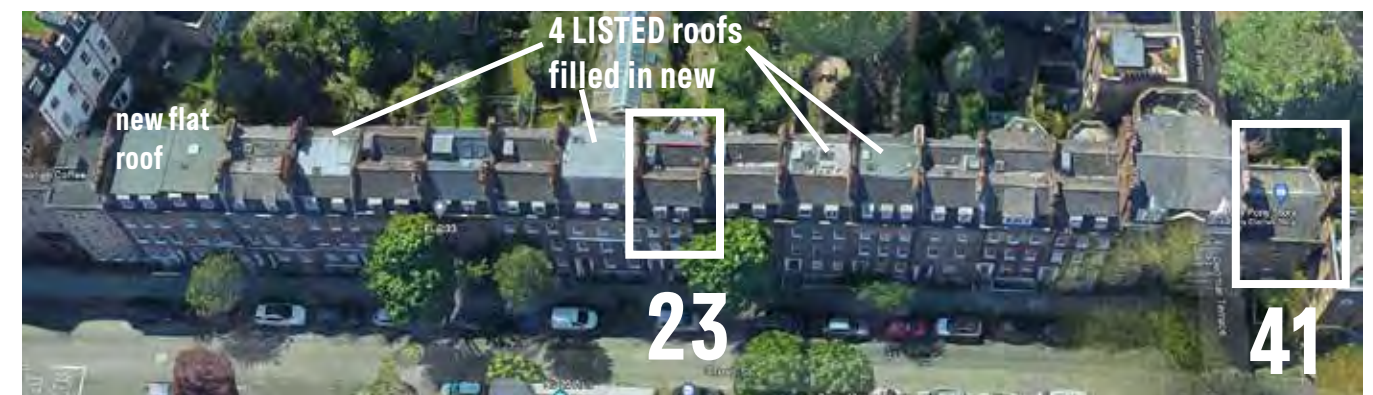

ESSEX ROAD

The 3 permitted extensions are to traditional roofs which have been damaged. Numbers 74 and 76 have been extended with a modern flat roof mansards; only 72 has not been extended.



HALTON ROAD

Listed terraces with only No 8 allowed traditional roof extension as it is a new replica house, extension will make it higher than rest of terrace.

All images this page- Imagery © Google 2022, © The GeoInformation Group 2022



AUDIT Proposed Extensions

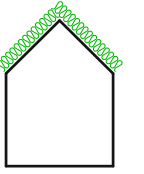

HARMED Heritage - rebuild new highly insulated

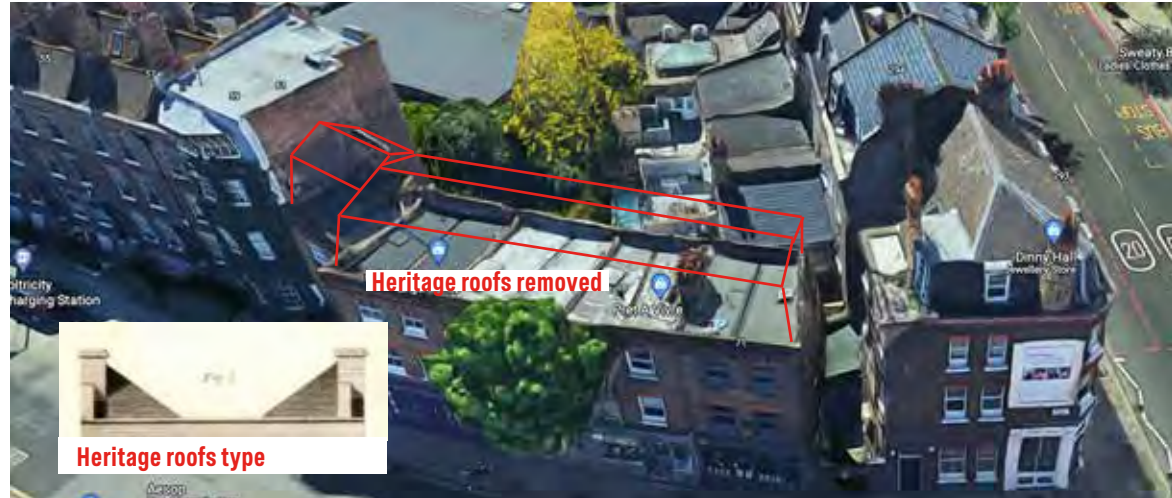

63, 65, 69, 69, 71 CROSS STREET Google 2022, © The GeoInformation Group 2022
Original visible inverted pitch hip roofs and chimneys removed for modern thin poorly insulated flat roof. It is 1 1/2 storeys lower than buildings to either side.

In Bath advice is, 'Building or shoulder height along streets should **not be less than** or exceed the prevailing cornice height of nearby Georgian buildings'. (Bath Evidence Base Urban Design and Heritage Part 3, Building Heights Strategy).



Google 2022, © The GeoInformation Group 2022



Removed Chimneys & original **Inverted Pitch- Hip Roof** (shown in red).

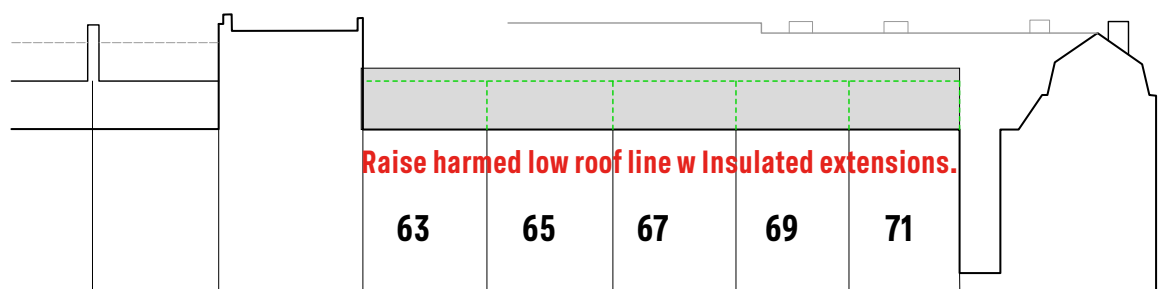

Set Terrace Height STANDARD & allow visibility



Imagery © Google 2022, © The GeoInformation Group 2022

9, 11, 12, 13, 14, 15, 16, 18, 22 DAGMAR TERRACE

Set back extensions with front terrace aligning with each other should be encouraged. Six extensions have been built to old standards. These extensions involve loss of deep loft space with new flat roofs/terrace areas which can reduce the thermal performance of the building. Flat roofs need to be able to be heavily insulated. LETI recommends minimum of 300mm in roofs/ terraces.

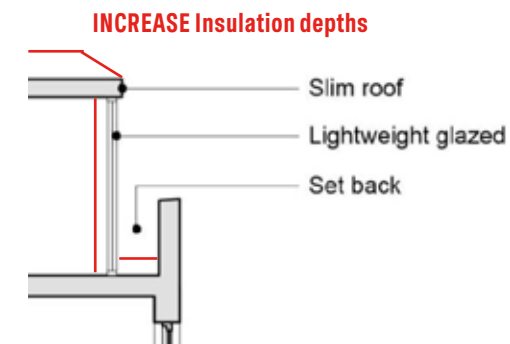

Current practice slim roof needs 'woolly hat' thicker insulation



Google 2022, ©The GeoInformation Group 2022

23, 21, 20 & 17 Dagmar Street Extensions



23 Dagmar Street -long view show differing roof heights



21 & 20 -long view show differing roof heights

EXTENSIONS ARE VISIBLE FROM PUBLIC REALM



AUDIT Proposed Extensions

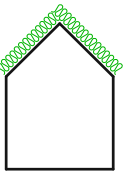

EXTEND Building Heights



2, 3, 4, 5, 6 DAGMAR TERRACE

Terrace of 5 houses classed as Negative in the conservation area due to being lower and out of scale with poor façades and windows.

Recommend highly insulated roof storey extensions. (along with externally insulated facades and new windows)

Imagery©Google 2022©Geoinformation Group 2022

112 ESSEX ROAD

This terrace house, has had original heritage pitch roof replaced with a modern thin poorly insulated flat roof. **Recommend visible highly insulated** mansard or M roof extension.



105, 107, 109, 111 ESSEX ROAD 2, 4 CROSS STREET

This parade of 6 shops is classed as Negative in the conservation area due to being lower out of scale, although shopfronts are positive.

Recommend highly insulated storey extensions.



HALTON CROSS

This garage/workspace is classed as a Negative Building in the conservation area due low scale and position.

Recommend highly insulated roof extension with externally insulated façades with windows.

EXTEND to align with remains of destroyed Terrace

87, 89, 91 ESSEX ROAD

This terrace of three houses is classed as a Negative Building in the conservation area due to being lower out of scale with floor heights not matching original destroyed terrace, poor windows and facade. They are suitable for additional floor with mansard matching line of heritage terrace. Additional storey wall to match existing terrace plane with possible balcony at transition. Roof slates reused on new extended 3rd floor mansard.

Recommend visible highly insulated mansard extension to match original destroyed terrace height aligning to what remains of terrace.



Imagery©Google 2022©The GeoInformation Group 2022



Imagery © Google 2022, © The GeoInformation Group 2022

SPD TECHNICAL Roof Extension

Current Conservation Practice Roof Extensions

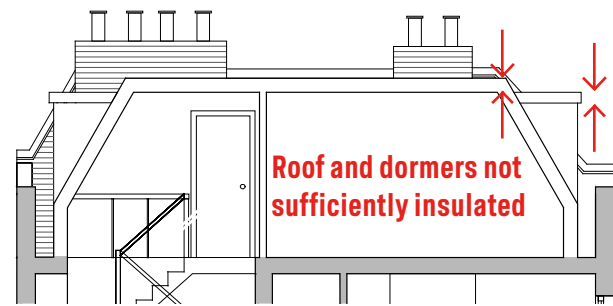
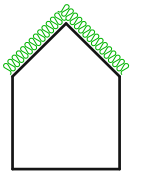

Approved **2016**, 54 Cross Street

Planning sometimes prioritises low extension heights to the detriment of insulation. This example typical from 2016 granted within CA13 has a modern flat mansard roof with poor insulation. Dormer has low insulation levels and the mansard roof does not link to any internal or external wall insulation. Does not follow 5 degree roof from Fig 23 below.

The approval June 2021 has poor roof, wall, and terrace floor insulation and no link to any internal or external wall insulation. Overheating glass.

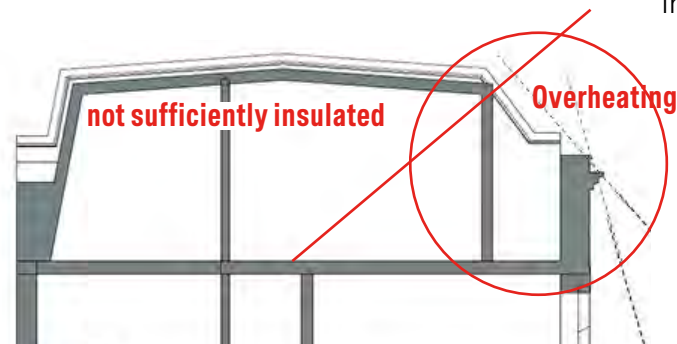

Approved June **2021**, 14 Dagmar Terrace. Large South facing windows south overheating.

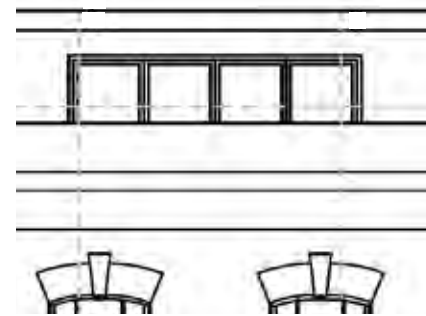

CURRENT Islington Approvals, LOW ROOF HEIGHTS

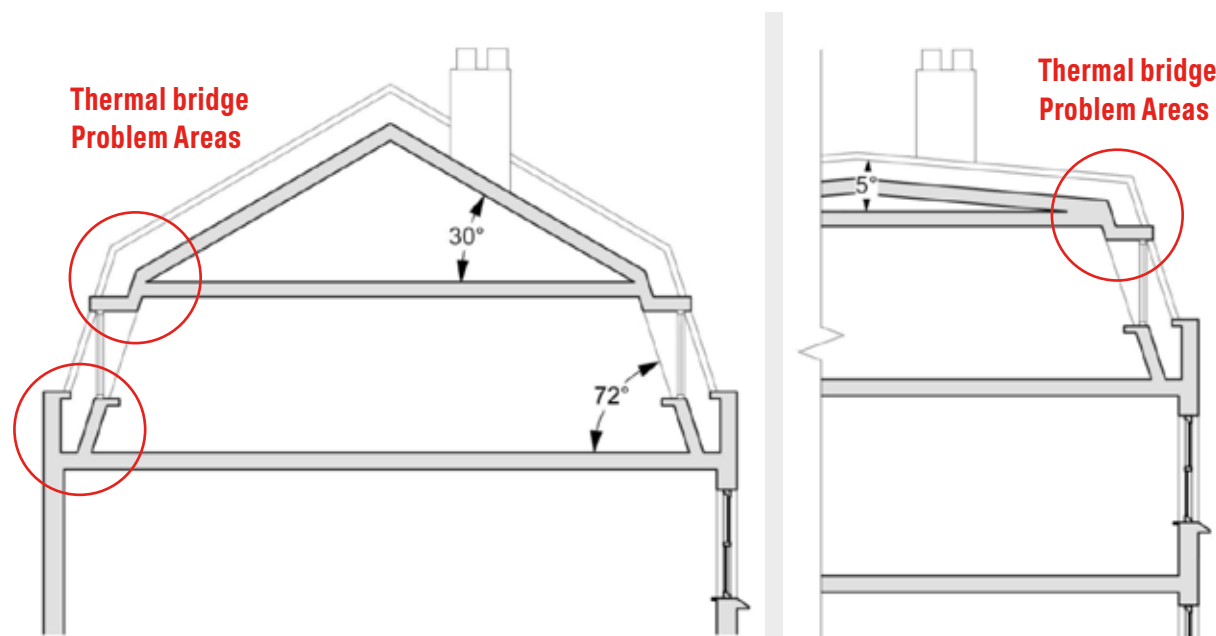

Figure 23 Types of mansard roof extensions. Traditional double pitch mansard roof with dormer windows (left) and flat half mansard roof with dormer windows (right).

CURRENT Guidance, Slim Roof Details can't accommodate insulation

Islington Urban Design Guide (2017)

Better Practice - Cold Bridge Junctions

Planning Principles - ROOF HEIGHTS

The Georgian city of Bath matches height of adjacent buildings, 'Building or shoulder height along streets should not be less than or exceed the prevailing cornice height of nearby Georgian buildings. One **additional setback storey** behind parapet within the roof scape **is generally acceptable**'. (Bath Evidence Base Urban Design and Heritage Part 3, Building Heights Strategy). This principle is that buildings are not lower or higher but can go higher with a set back storey.

In the 2017 Urban Design Guide Islington mentions good design is generally consistent height of terrace roofs. Paragraph 5.147, 'An extension that projects significantly above or alters the prevailing roof line can often disrupt the characteristic rhythm/unity'. Key words are 'project significantly' which leaves scope for properly insulated roofs to be slightly higher than poorly designed ones.

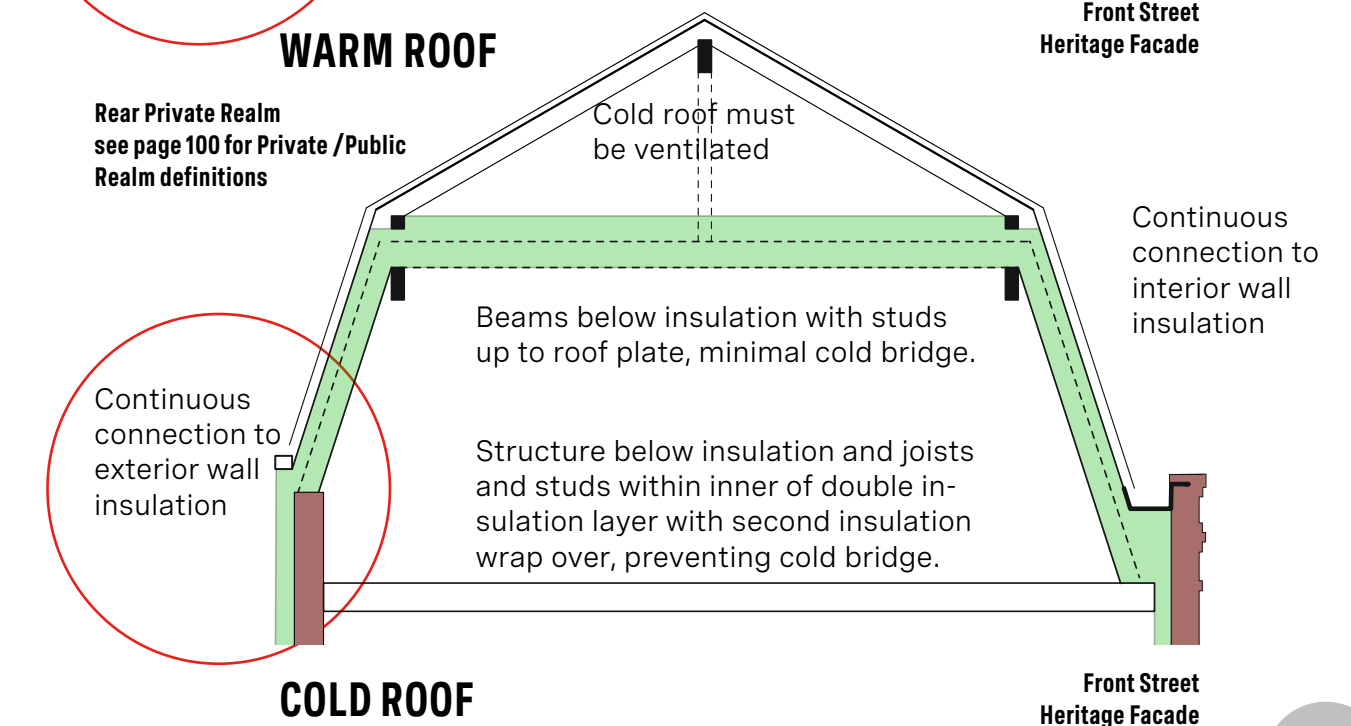
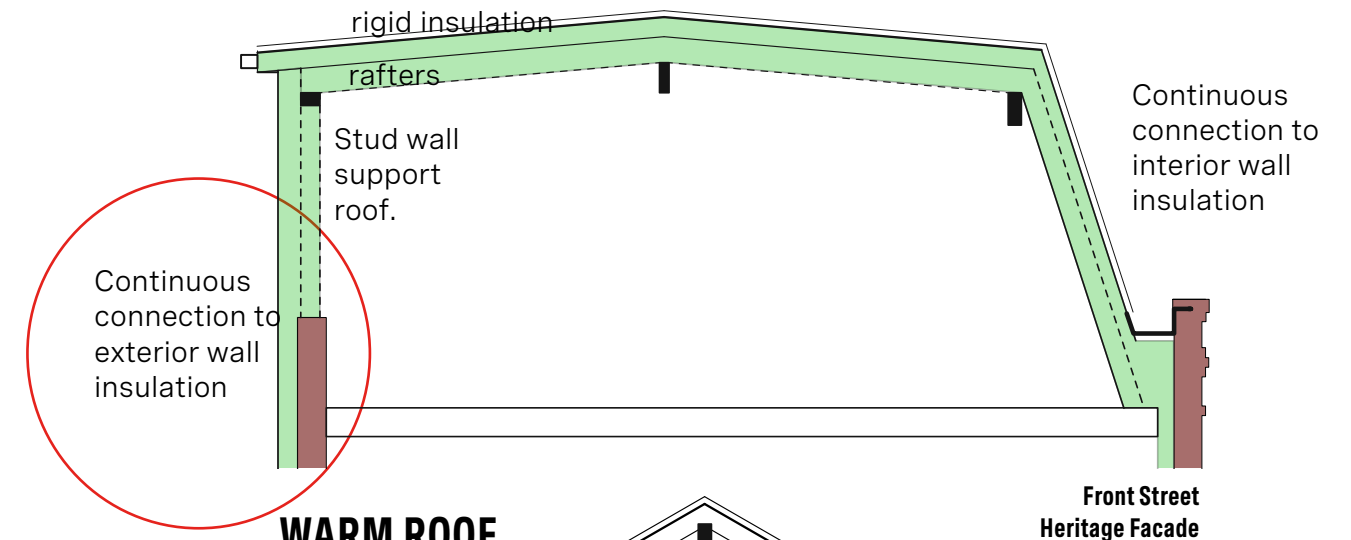

CONTINUOUS INSULATION cold bridge prevention



SPD TECHNICAL Cold Roofs

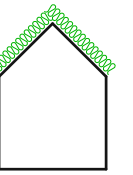

Proposed Extension COLD VENTED ROOF

New proposed practice emphasises **continuity of insulation** wrapped walls and roof. The section drawings shows 2 standards; **Building Regs 2021** minimum versus **Better Standard** which is achievable with slightly more insulation at not much more added cost.

Traditional Cold Roofs need to be vented. Advantage here over warm roofs is natural insulation batts or loose fill can be used.

All U-values are W/m²k

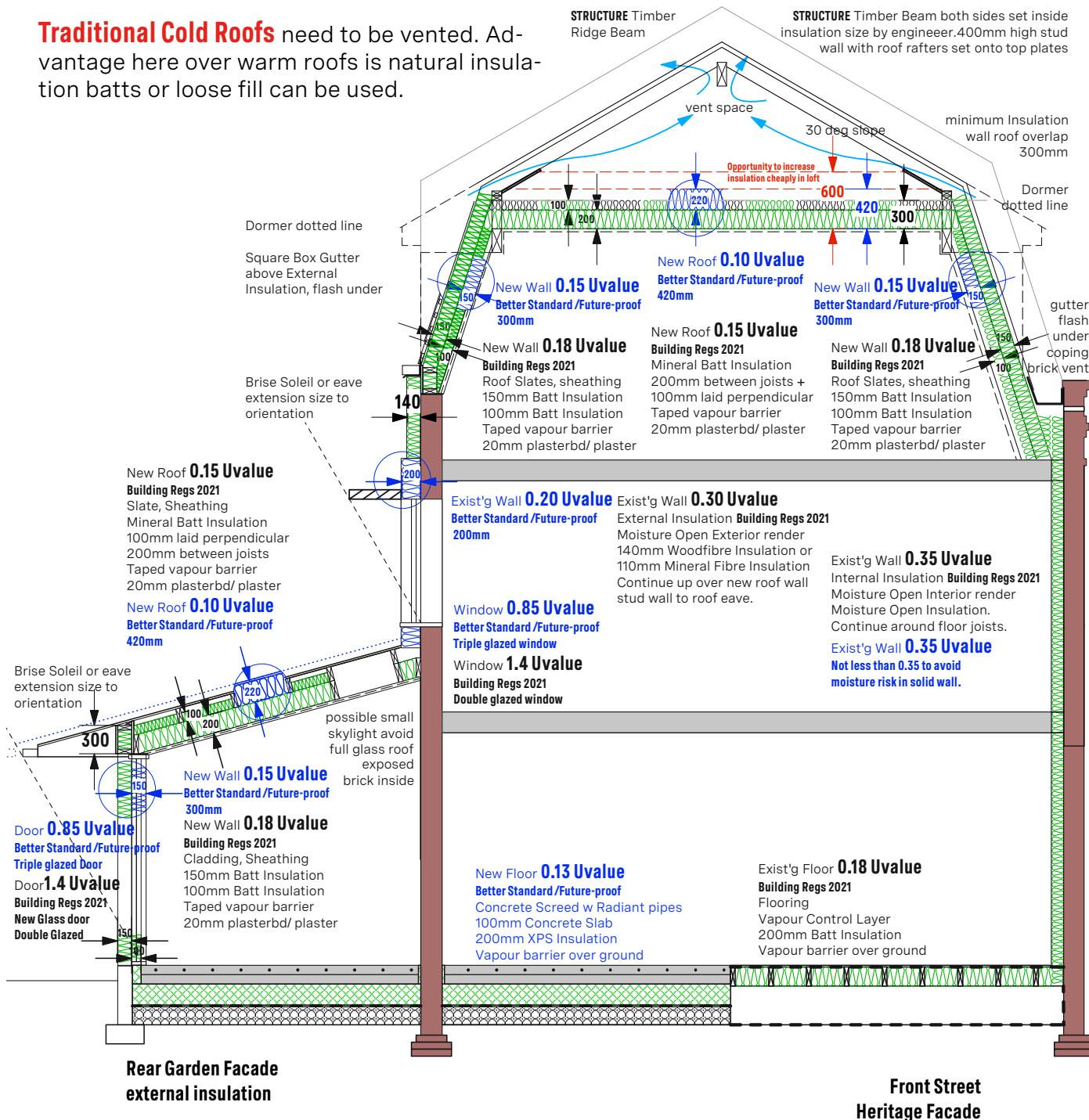

Proposed Extension Dormers COLD VENTED ROOFS

All U-values are W/m²k

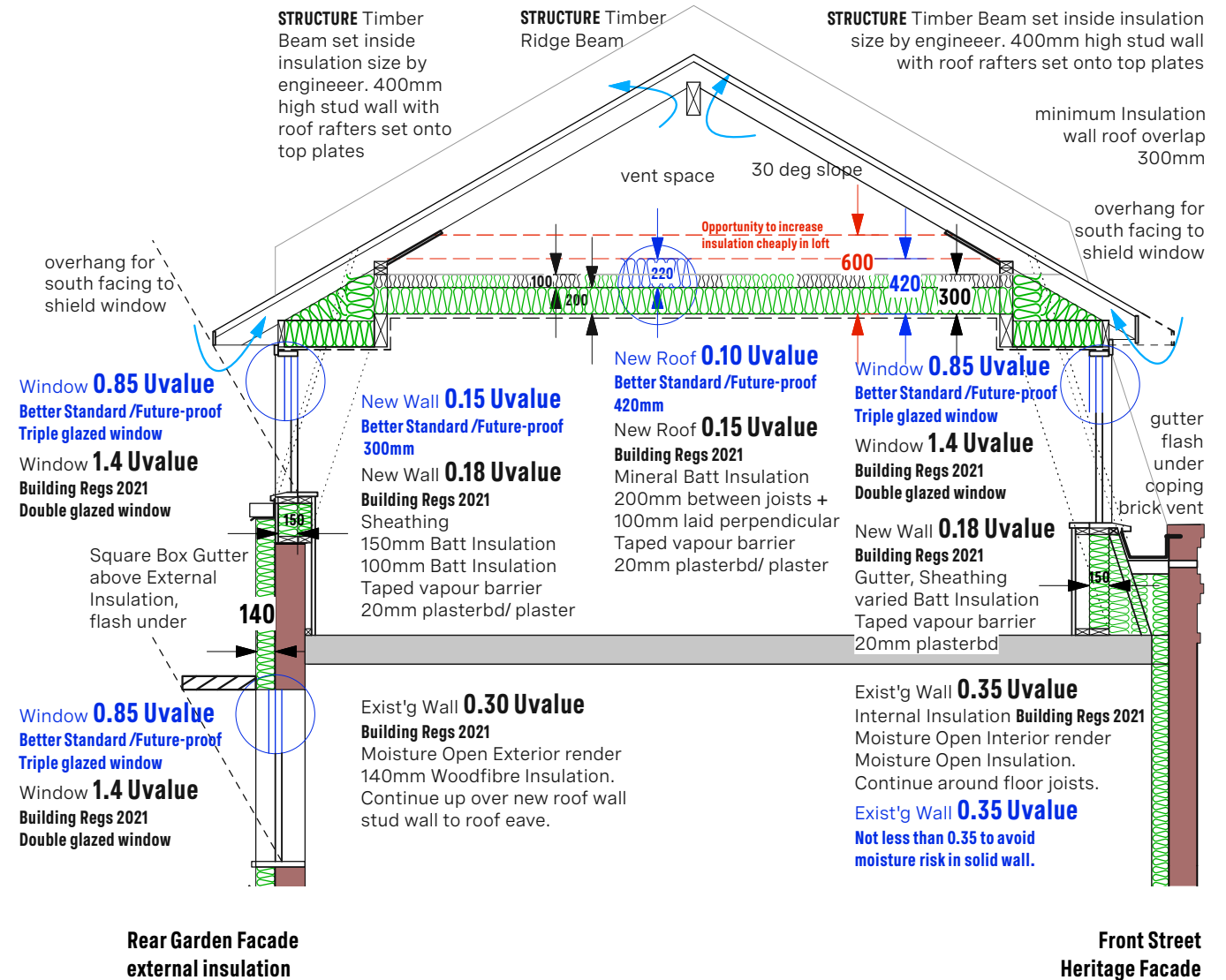

Double Pitch Mansard Roof - Section through Dormers

Double Pitch Mansard Roof - Section through Rear Garden Extension



ROOFS SUMMARY

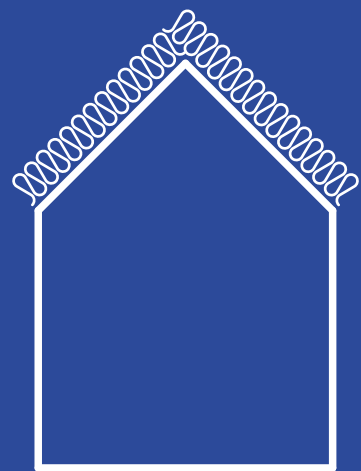

up to **25%** of heat loss therefore roofs are of prime importance to retrofit.

Traditional Loft Insulation

- 8 Mansard- loft insulation
- 32 Inverted- loft insulation
- 10 M roof- loft insulation
- 11 Ridge- loft insulation
- 1 Hip- loft insulation
- 27 Double Ridge - loft ins

89 (of 173)
Heritage Roofs
trad. lofts insulate as possible

51%

Recent Extensions Retrofit when can

- 27 new Mansard/Modern insulate when roof fails
- 13 new Flat Roof Gardens insulate when roof fails
- 12 new Flat Roofs max ht. insulate when roof fails

52 (of 173)
Old Standard
recent retrofit when repairing

30%

New Extensions Climate Emergency Retrofit

- 2 Existing Permitted, Mansards
- 15 Out of scale Neg. buildings, Full Floors new construction
- 6 Damaged Heritage roofs, Mansards or Recessed
- 9 London Roof, broken teeth, or Parapet Recessed Extensions

32 (of 173)
High Standard
300-600 roof insulation
minimal thermal bridges

19%

Through careful analysis of each roof type in Islington CA13, 19% of all roofs can meet High Insulation Standards without harming heritage. This is extending damaged roofs with well designed ones and extending negative low buildings. Unfortunately 30% of all roofs have been built to older low standards and so would need retrofitting when they need repairing in the future. For the 51% remaining listed and heritage roofs, mostly listed buildings, energy savings can be achieved with careful loft insulation as per Historic England recommendations to achieve Building Reg 2021 or better.

Inverted Butterfly or London roofs are difficult to insulate at the centre gutter due to lack of space and cold bridging through the structure. There may be a case for modifying these roofs.

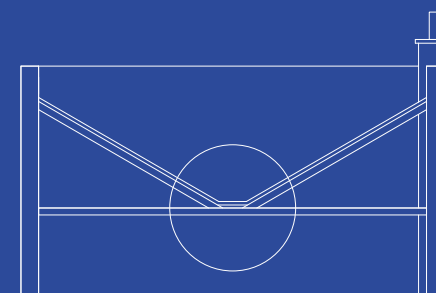

RECOMMENDATIONS

Consent Orders and SPD Guidance details to be developed by council for local typologies.

1. Develop Permitted Development for local Roof model types. Householders need local models to follow where planning will be approved, saving council money and resources on duplicate applications.
2. Request all roof proposals to be cold bridge free with roof insulation link detail to current or future wall insulation.
3. Mandate all roof proposals to meet new standards even if those roofs will be higher than neighbouring roofs. Slight height differences will not be significant. (Bath evidence p47)
4. Relax the practice on extension visibility. Many of the approved extensions are indeed visible from long views. Over emphasis on visibility leads to low ceiling heights and structures resembling garden sheds rather than heritage roofs.
5. Amend CA Guidance documents with permitted roof extensions as per new Toolkit audits clearly listed by property address. See Islington CA13 example on page 159.

2.5.2 Projecting Features

'Put on an ear muff.'

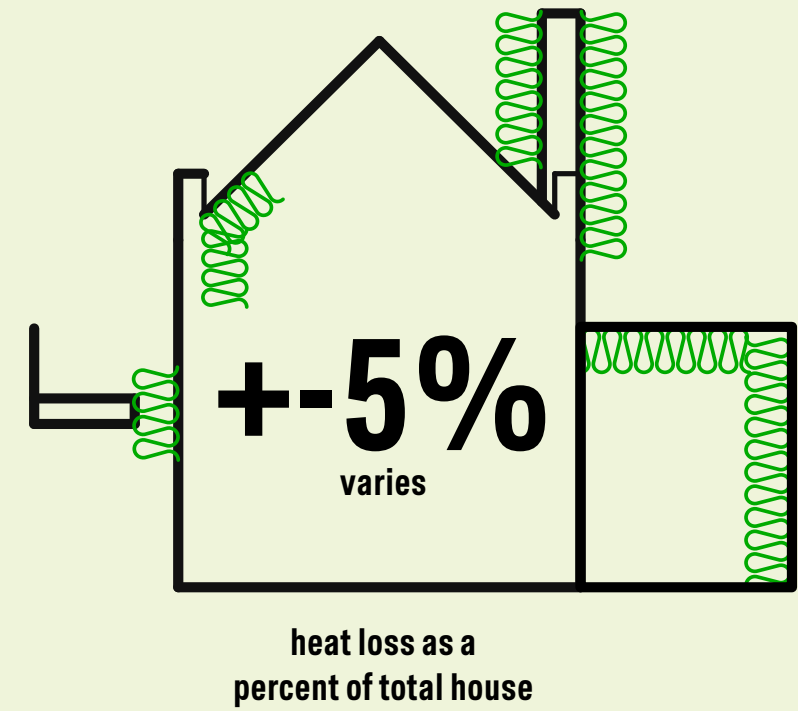

AUDIT Chimneys mapping

Traditional roofs in this area have chimneys built into side party wall of the terrace houses. Roofs which are original will need insulation placed inside the loft with enough extended around chimney breasts and party walls to delay the significant cold bridge through the mass. The 42 buildings without chimneys are: modern without chimneys, traditional with chimneys removed, or 12 traditional buildings which have had roof extensions without extending their chimneys.

Chimneys should not be replaced in buildings where they have been removed unless it is a significant listed building. In a no combustion world we need to reconstruct our view of the ideal home without the chimney.

24% lack chimney or chimney was removed

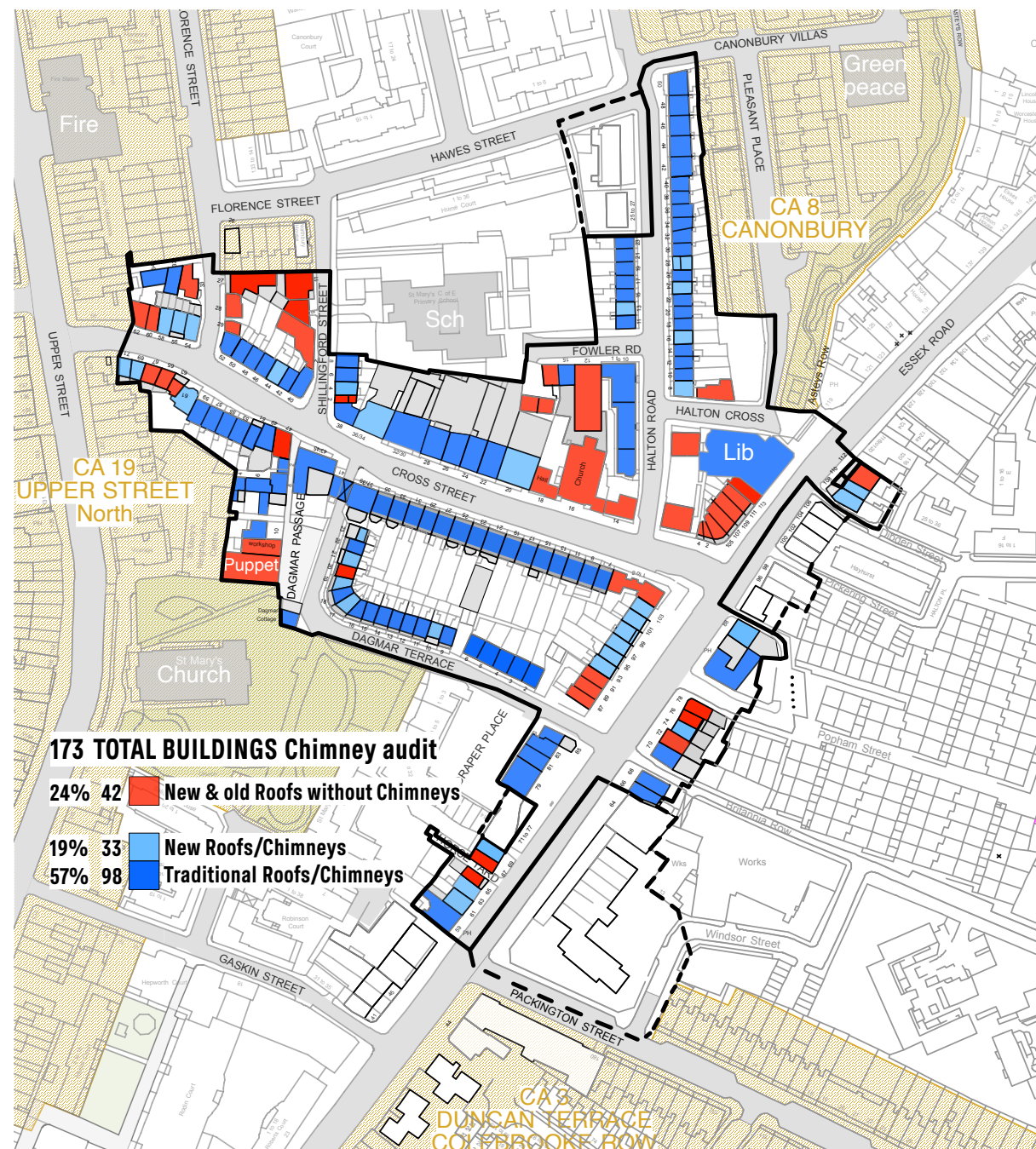

Chimneys /Party walls Cold Bridges

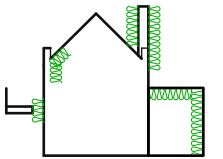

In the example below, the heritage inverted roof was removed along with the chimney in a non listed house. Rebuilding a replica chimney is no longer practical because: the structure below can be missing, it would create a large cold bridge and cause potential damp. Chimneys are now only decorative features as they are not useable.



A new roof extension would be built to highest new construction (Building Regulations or greater) standard which puts a wooly hat over this building. Party walls could be extended or, a fire compartment wall built under a continuous roof spanning multiple terrace houses. The fire compartment wall would be preferable to the party wall which causes a cold bridge through the exposed brickwork.

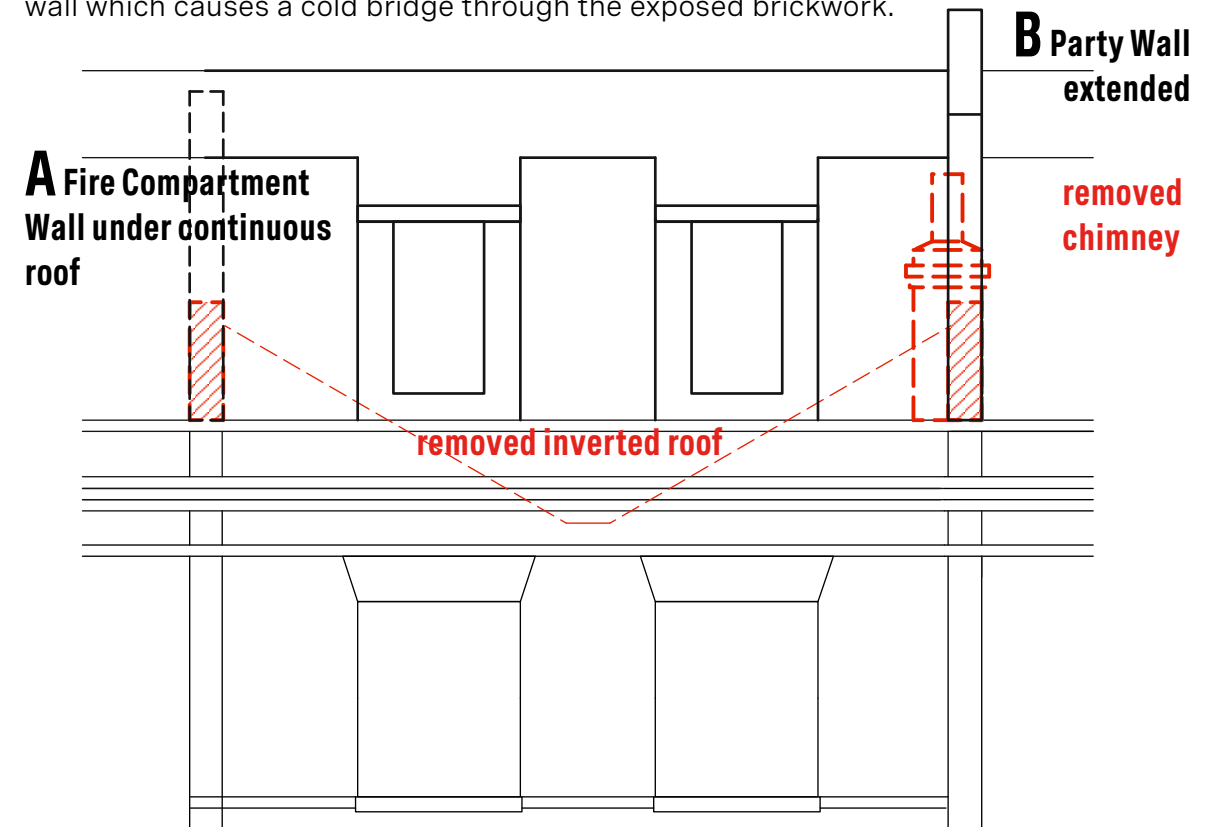

Where chimneys or roofs have been removed they should not be reinstated



78 Essex Road



88 Essex Road



62 & 60 Cross Street

Lack of chimneys in these new extensions are not obvious from public realm.



SPD PRINCIPLES Compact Form

Measure of Compactness

Terrace Houses are very efficient compact forms with shared walls. See the sphere diagram below. Rear extensions need to be carefully considered as they can increase exposed surface area without providing much space. Individual extensions are the worst with 3 walls and roof exposed. Double extensions which share a party wall are better with only 2 exposed walls and roof. Best is a continuous extension with only 1 exposed wall and the roof.

Terrace Extensions

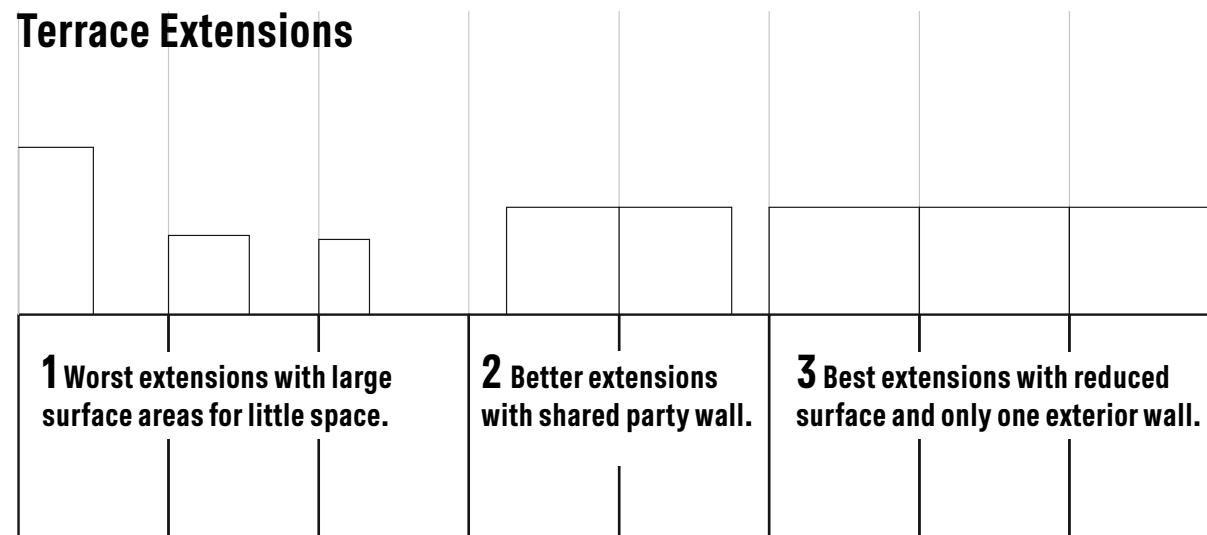

The mid terrace house has a very good Compact Form as the shared party walls remove two surfaces. Rear extensions can decrease or increase the exposed surface area (by infilling or projecting)

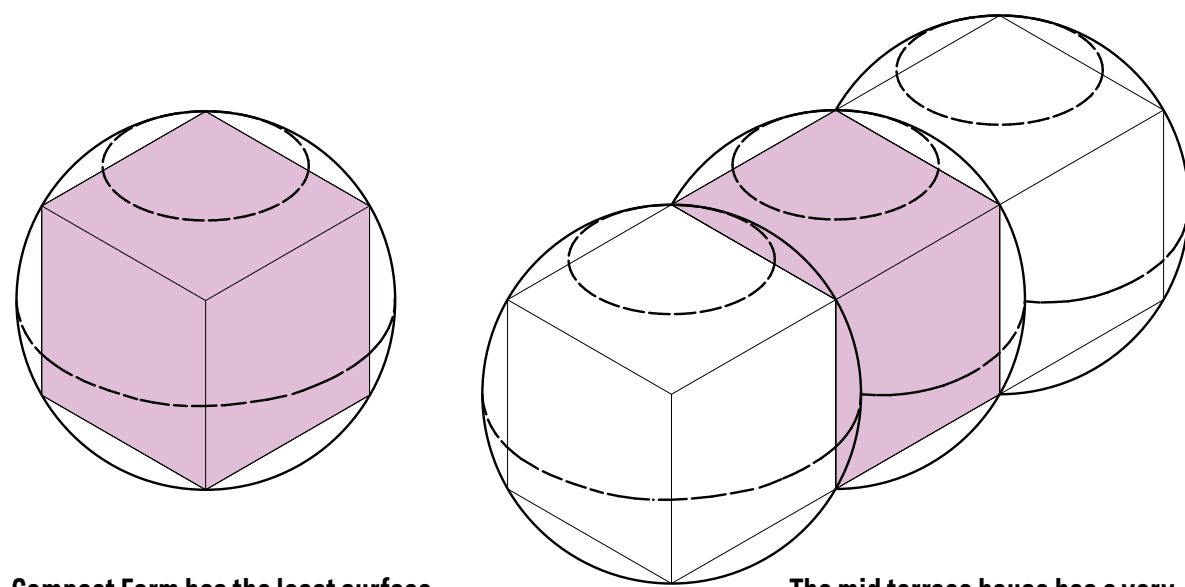

Compact Form has the least surface area for the most volume such as a sphere or a cube.

The mid terrace house has a very good Compact Form as the shared party walls remove two surfaces.

House TYPE Form Factor

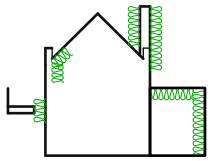

'The Heat Loss Form Factor is one way of measuring the efficiency of the surface area of the thermal envelope.'

The Heat Loss Form Factor is the ratio of thermal envelope surface area to the treated floor area (TFA). This is effectively the ratio of surface area that can lose heat (the thermal envelope) to the floor area that gets heated (TFA).

In other words, the Heat Loss Form Factor is a useful measure of the compactness of a building. And the more compact a building is, the easier it is to be energy efficient. Conversely, the less compact a building is, the more insulation will be required for the building to be energy efficient.¹

Elrond Burrell , What is the Heat Loss Form Factor? Blog 03 Aug 2015

Measure of Form Factors for different house types

The Heat Loss Form Factor is a number generally between 0.5 and 5, with a lower number indicating a more compact building.

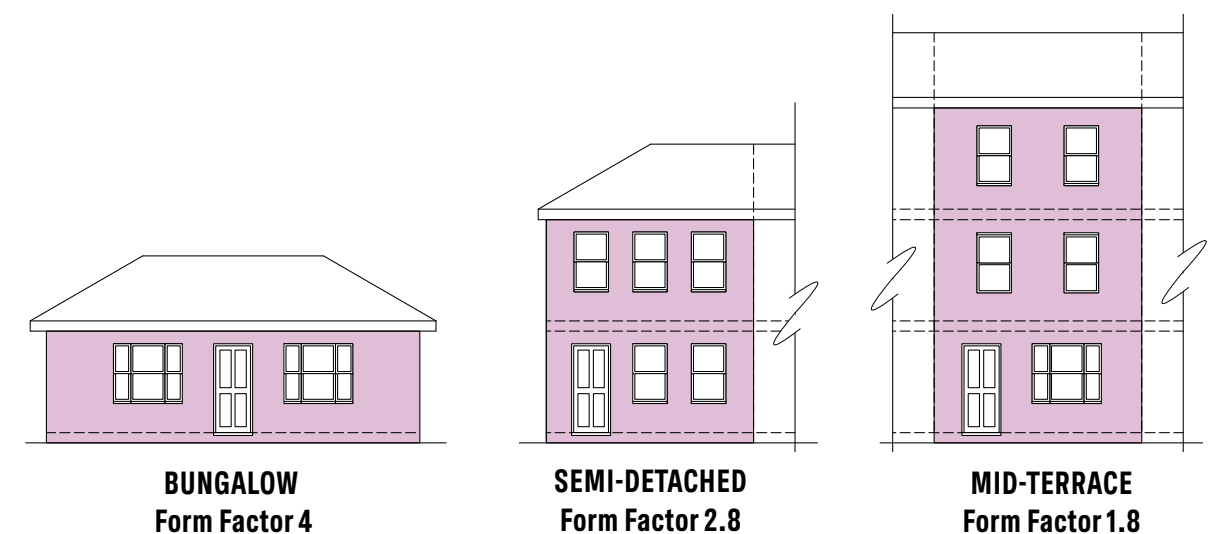

¹ <https://elrondburrell.com/blog/passivhaus-heatloss-formfactor/>

PROJECTING FEATURES SUMMARY

The Georgian and Victorian terraces of CA13 were built without rear extensions. More recently a few small extensions have been added for bathrooms as these houses did not have them. Where extensions are required modern principles of form factors can be applied, as shown before.

With the ban on burning coal many chimneys were removed in the 1960-70's, by removing the chimney at roof level or even the entire chimney breast down through the building. Also many new mansards have been built without chimneys. New modern roofs may not need artificial chimneys rebuilt if the building is lacking them.

Parapet walls at the rear private realm of buildings may not be required as contemporary practice is to insulate externally wrapping up into the roof.

Balconies or Porches should be built structured from the ground and not rely on fixing into and through the solid wall and insulation of the building.

There is a difficulty in setting standard rules as each building is unique but there are terrace and other groups of repeating houses where clear principles can be applied generally.

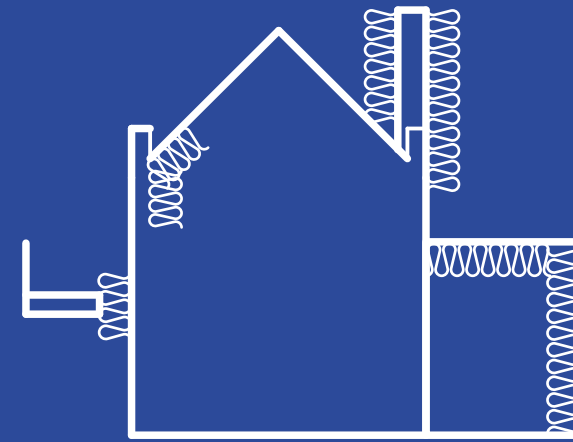

RECOMMENDATIONS

SPD Guidance details to be developed by council for local typologies.

1. Where chimneys have already been removed allow new roofs without chimneys.
2. Parapet walls present cold bridges therefore careful insulation must either cover and wrap over and down to external insulation. Where the parapet is of heritage or architectural significance on the front of the property insulation must link behind to internal wall insulation.
3. Existing and new extensions must take into account form factor implications. New extensions should fill in gaps; they should not increase the total exposed surface area unless there are no extensions to adjoining houses.
4. Balcony or porch additions should be structured from below and not rely on cold bridge connections into existing solid walls. Guidance details to be developed by council for local typologies.

2.5.3 Renewables -Solar, HP

'Bask in the sun.'

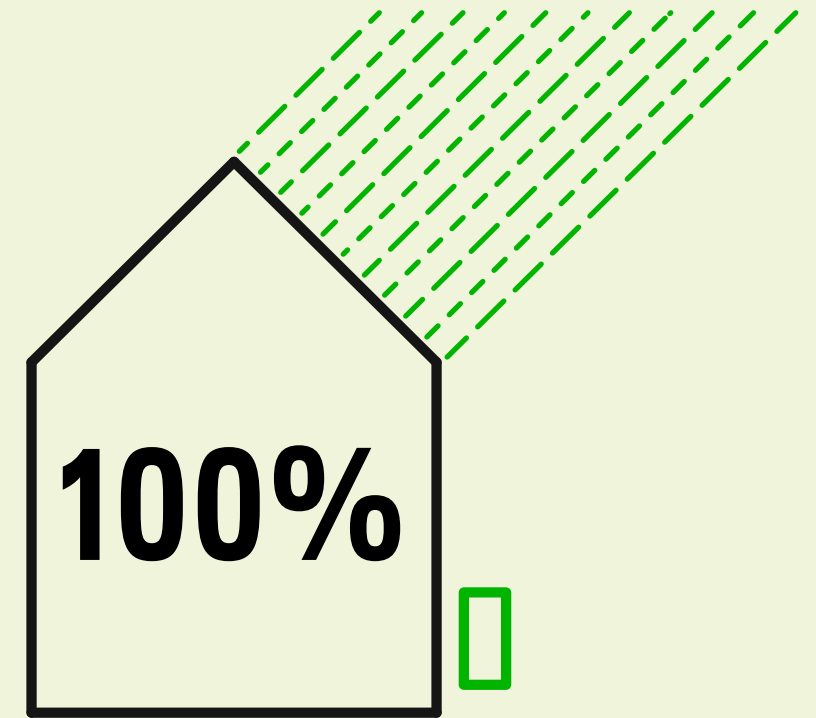

A typical 3 bed UK house with gas central heating consumes 3000kWh of electricity and 12,000kWh of gas per year.

Adding 2-4kWp of solar PV panels can meet the net total electricity use, however due to difference in time of generation and demand, electricity will still be imported from the grid.

If the gas central heating were to be replaced with a heat pump, then an additional 4-6kWp of solar PV panels would be required to generate the net annual electrical energy needed to run the heat pump. Again due to difference in time of generation and demand, electricity will still be imported from the grid. Better insulation is essential prior to fitting a heat pump to minimize heat demand, minimize heat pump cost, and reduce the potential grid electricity.

AUDIT Solar Roofs mapping

34 Halton Road, Only current solar installation, 10 Panel system on both sides of inverted pitch roof. South face 4 panels more efficient than north slope 6 panels. For Halton houses south slope only may be better due to chimneys shading.

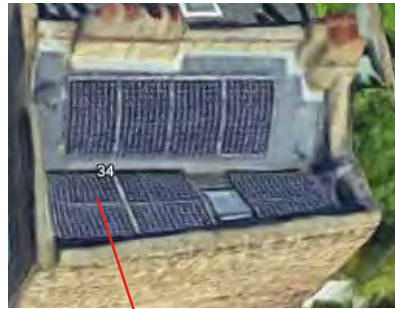

31% of roofs are solar suitable

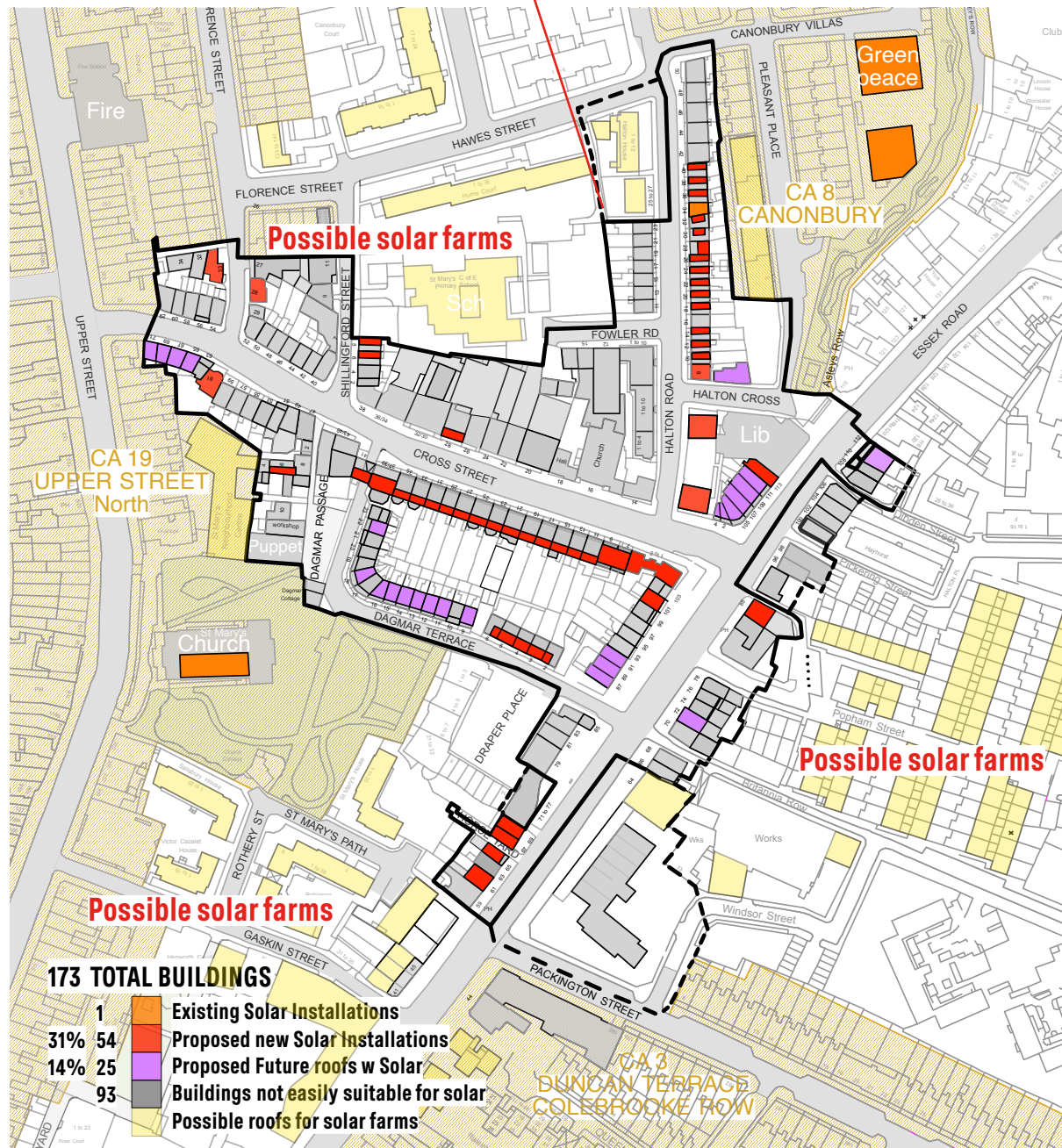

Solar Audit - ACAN worked example London Borough of Islington CA13

40 year warranty now possible-

Sunpower Maxeon¹ generating **88.3% in year 40**
no replacement needed, continues to function beyond warranty

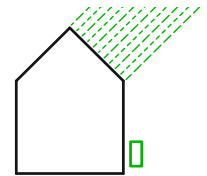

The roof audit found only one solar installation in the Conservation Area, see 34 Halton Road opposite page. It found potential for 54 more buildings (31% of the total) to have small solar systems on either flat roofs or south pitches. This number does not count the additional 32 roofs identified as suitable for future extensions which might have solar built in. This total of perhaps 86 is close to half the Conservation Area. Awnings, deep reveals, arcades etc are all responses to climate. It could be argued that the installation of solar panels is simply the latest in a history of architectural responses to climate and should be allowed visibly in Conservation Areas as long as they are well laid out (see layout design page 71) and do not damage the building.

Outside the boundaries there are large flat roof expanses on St Mary's Primary School and many council social housing blocks. These large roofs are potential solar farms. Islington Council could use its vast council wide flat roof assets to build multiple solar installations providing income such as Cambridge Council has done on land at its Triangle Solar Farm at Soham.² These 'solar farms' can either provide: council direct income, supply power to buildings they are on, or supply income to the local community. Solar power can be sold to building occupant or utility with income distributed to community stakeholders or individuals who invested in the installation. Conservation area homes not suitable for roof top panels could invest in offsite local 'solar farm' projects offsetting electricity cost they use.

installations in adjacent conservation areas
St Mary's Church (south roof slope) Greenpeace HQ (2 flat roofs).



119 panels on St Mary's Church Upper Street



Large flat roofs potential solar farm St Mary's Primary



Multiple flat roofs potential Solar farm on council estate



198 panels on Greenpeace HQ

All images this page- Imagery © Google 2022, © The GeoInformation Group 2022

¹ <https://sunpower.maxeon.com/uk/solar-panel-products/maxeon-solar-panels>

² <https://takeclimateaction.uk/climate-action/how-cambridgeshire-council-raising-revenue-solar-farms>



AUDIT London Solar Opportunity Map

from Environment Agency

The Solar opportunity map is a great resource to check individual rooftops for solar potential for London with data on expected electrical generation. Two rooftops in CA13 below, 61 Cross St (a single house) could generate 4,706 kwh/yr and 1-6 Cross Street (a block of flats) could generate 8,790 kwh/yr. The London Solar Action Plan has a 1 gigawatt target of installed panels by 2030. The London Solar Opportunity Map 2020, was developed by UCL Energy for the Mayor of London to plan this expansion.



61 Cross Street, solar potential

1-6 Cross Street, solar potential

Solar Opportunity Map , potential of all buildings across London, <https://maps.london.gov.uk/lom/>

Suitable Solar Roofs AUDIT

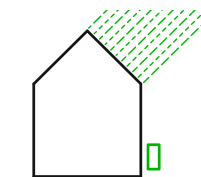

54

roofs, are now solar suitable

Mapping identified **54 smaller potential installations** on roofs that are appropriate for roof extensions. Some of the larger flat roofs are apartment blocks with multiple residences but many are individual homes which with 2-4kw systems could generate most of their electrical needs while they use gas heating; see page 65. Solar Tech has advanced with many companies such as Sunpower, LG, Panasonic, JASolar, Trinasolar, Hyundai energy solutions all achieving panels with greater than 400 watts/panel in 2022 which allows smaller arrays on smaller roofs.¹



¹ https://www.deegesolar.co.uk/the_most_efficient_solar_panels/



SPD TECHNICAL Flat Roof Solar

Many of the solar suitable roofs are flat. Flat roofs are the cheapest to install solar due to ease of install and maintenance. Normally panels are landscape south-facing with 30-35 degree inclinations. This works well on sloped roofs but uses lots of space on flat roofs to space apart from shading each other. These panels at 30deg incline also present wind uplift issues. The tub mount variation can prevent wind uplift with closed sides.

A new approach called East West uses the entire roof surface. Although not south this can generate up to 30% more power as back to back with small gaps gives more panel coverage. This layout is used at Greenpeace HQ; see below. Another advantage of East West is they can generate more power at peak morning/evening periods.



https://www.deegesolar.co.uk/flat_roof_solar_panels/



https://www.deegesolar.co.uk/flat_roof_solar_panels/

Landscape traditional layout

Lowest height is landscape layout with small side angled up. 30-35 deg London recommended.

Tub mount system.

Weight down with ballast; no fixing to roof, protected from wind uplift by solid tub sides, moveable for roof repair. Roof structure must be able to take additional weight.



https://www.deegesolar.co.uk/solar_panel_mounting/



© Google 2022, © The GeoInformation Group 2022

East West system narrow spacing East West System -Greenpeace HQ

Inverted Roof & Visible Solar Guidelines

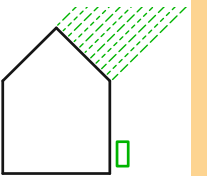

For inverted or London roofs, place solar panels high up roof as there may be some winter shading from chimneys on lower panels. Traditional string array systems should not be used. A better system so shade on one doesn't affect entire array would be panels with built in micro invertors like 'Sunpower Maxeon'¹ or individual panel 'SolarEdge' optimisers.² Use of the most efficient panels possible will generate the most power in limited space.³ There may also be a case to reduce redundant combustion chimney heights or remove chimney pots in order to reduce shading if they are set back and not visible from the street public realm.

For visible sloped roofs, panels can be designed to fit the roof compatibly with a neat grid or a designed shape. Panels come either with the common silver cell divisions as with 34 Halton road example directly below or can be all black as the triangular roof example bottom right. This all black panel simpler system may be more suitable if visible.

potential winter shading from chimney



34 Halton Road hidden system

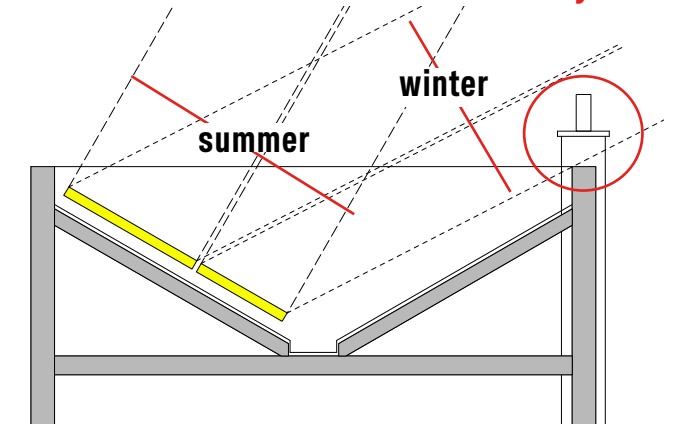

Section through inverted London Roof

All images this page- Imagery © Google 2022, © The GeoInformation Group 2022

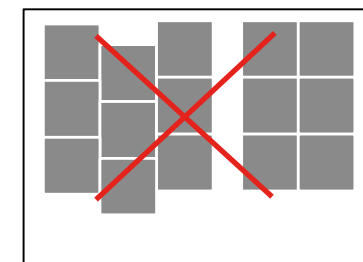

Messy layout unevenly spaced not acceptable



41 Cross Street visible roof. Possible neat grid layout.



Designed layout triangular roof panels complement.

Visible Roof Panel Layout Design

For visible systems the panel layout should be a neat grid or designed shape that complements the building, see St Mary's church page 61. Do not shift panels to go around dormers or vent ducts. Reroute any roof ducts within loft away from panel locations.

¹ <https://sunpower.maxeon.com/uk/solar-panel-products/maxeon-solar-panels>

² <https://www.solaredge.com/uk/solutions/residential#/>

³ https://www.deegesolar.co.uk/the_most_efficient_solar_panels/



SOLAR SUMMARY

Toolkit Proposed

54 (of 173)
Solar Roofs

31%



Current Condition

1 (of 173)
Solar Roofs

0.6%

Solar panel installation is a Permitted Development unless a relevant Article 4 Direction is in force. However, retrofitting is difficult enough in Conservation Areas without restricting solar panel sites unnecessarily. Conservation Areas need to employ solar to offset more difficult heritage retrofit. If CA planning guidance identifies suitable roofs it would give householders assurance and save planners time and cost.

Flat roofs are the cheapest systems and with low height landscape layouts many will be hidden within parapet walls or low enough to not be visible. Roofs can be assessed for suitability using the London Solar Opportunity Map developed from Environment Agency Lidar data by UCL. Typical UK home systems are 4kw. Small roof areas benefit from using most efficient panels currently about 400watts/panel optimised with separate inverters/panel. Panel optimisation means that shading or dirt doesn't impact the generation so significantly.

Inverted roofs on terraces can be ideal for solar panels and not controversial as most are hidden by parapet walls. Visible systems on sloped properties can also be acceptable if well designed (a clean rectangular grouping rather than uneven panel layouts) and should be encouraged.

Group buying schemes would allow Conservation Areas residents to purchase systems cheaper and get uniform design, better for Heritage area aesthetics. Solar Together London is a scheme which Islington has been a member since 2019.

& HEAT PUMPS



Solar farms can also be set up on local large flat roofs for income to building freeholder or jointly with local community stakeholder investors. Energy generated can be sold directly to the building with surplus sold to the grid. Stakeholder investors can be the building leaseholders or other local homeowners such as heritage houses difficult to solarise. Solar generation income will offset heritage house energy consumption bills.

<https://www.london.gov.uk/what-we-do/environment/energy/solar-together-london>

HEAT PUMPS

Heat Pump outdoor units to be in private realm or roof top not visible from public view, unless screened with louvres or similar. Fully indoor units may need venting through wall with discreet vents which may be acceptable.

RECOMMENDATIONS

1. Develop SPD guidance of Solar System roof typologies such as: inverted, sloped, and flat roofs with detailed technical and aesthetic guides.
2. Permit Solar in Conservation Areas on both listed and non-listed properties with Local Listed Building Consent Orders such as Kensington & Chelsea (March 2022). This proactive guided approach will remove the need for planning permission.
3. Relax rules on visibility for systems that follow prescribed aesthetic in design guidance SPD & Consent Orders.
4. Develop initiatives for local council or community solar farms and group buying schemes promoted through a Climate Centre and local outreach commitments.

2.5.4 Windows

'Wear the correct lenses.'

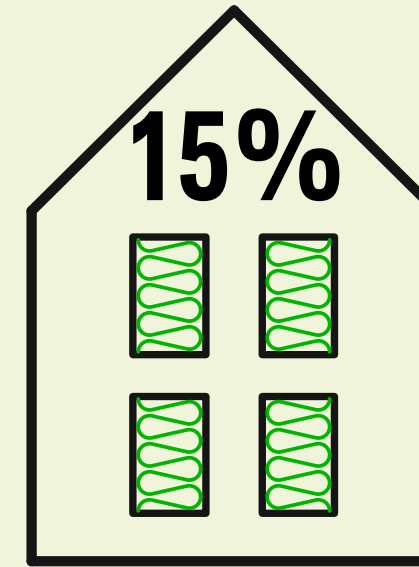

window heat loss as a percent of total house

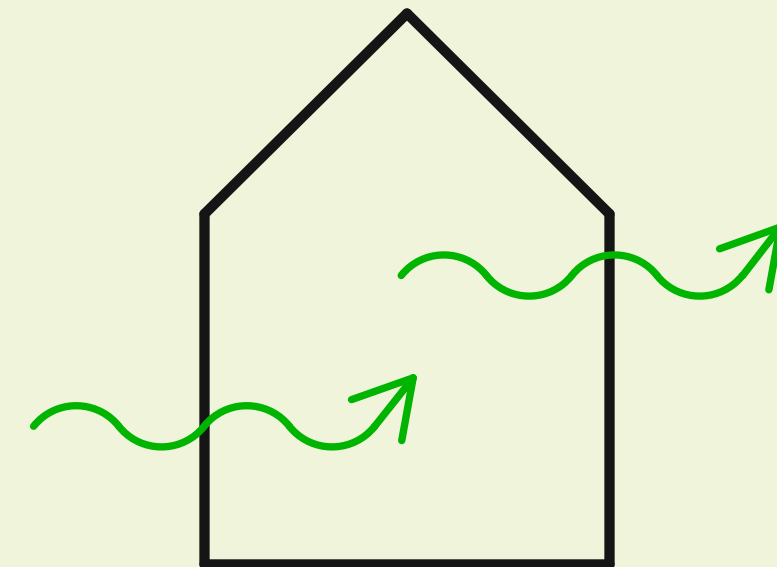

Ventilation required with new windows

AUDIT Windows mapping

CURRENTLY For detailed window mapping audits & photographic surveys by Category See Appendices pages 147-157.

81% Single Glazed (140 of 173)

14% Double Glazed (24 of 173)

5% Bad Double replace (9 of 173)

bad are damaged or inappropriate window type

75% of windows (130 of 173) could be double/triple with existing 14% = **89% Total**

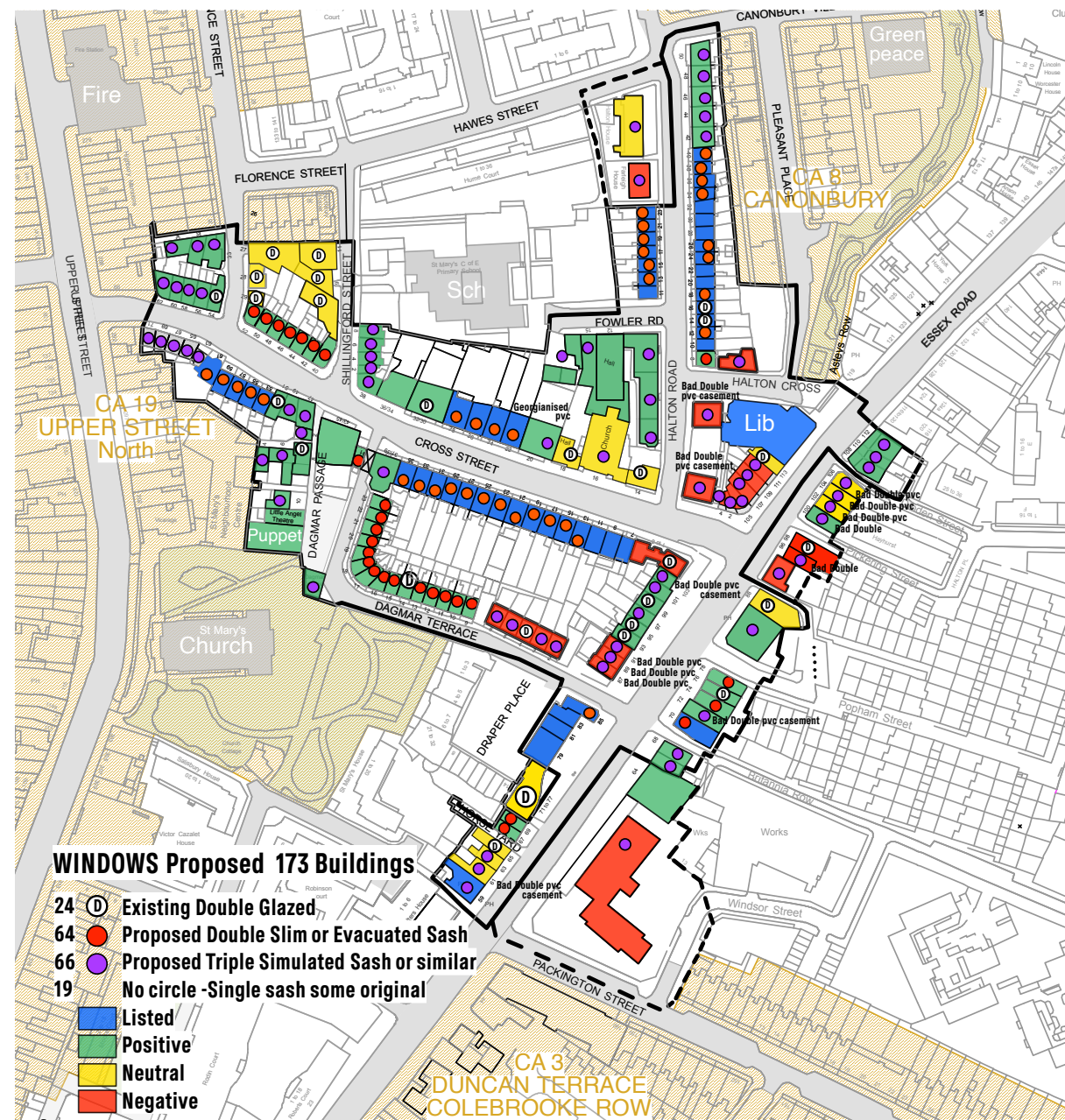

4 Local Window Types AUDIT

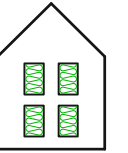

The oldest buildings in this area of Islington are Georgian. All 52 Georgian buildings within CA13 are listed along with a Victorian pub and Library. The largest group of buildings are 93 Distinctive and Functional Victorian buildings. The remaining few buildings are post war social housing and a few contemporary houses on redeveloped or war struck sites.

Windows can be grouped into 4 categories; Classical Georgian sash, Distinctive Victorian sash, Functional Victorian sash and Modern insulated casement windows (some original and some replacing single glazed metal Crittall windows).

Within these groups many of the windows are damaged or have been incorrectly replaced. **Very few, if any, Georgian windows survive, as sashes with horns indicate replacement.** Detailed analysis follows for each type with recommendations for Heritage repair with Climate Emergency appropriate windows.

7 Replacement windows follow in the Technical pages.

Modern casement

20th - 21st century 1930-2022

best technology tight gasket seals triple glazed and aluminium wood frames

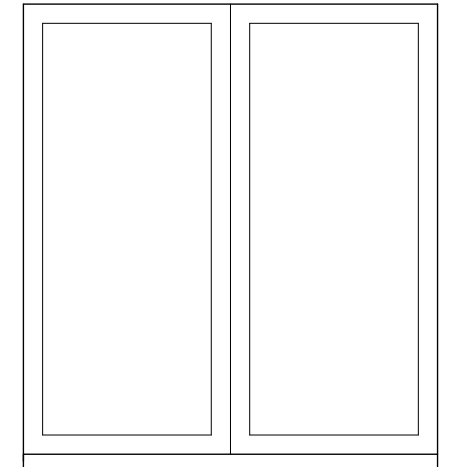

Many Manufacturers

Classical sash

Georgian 1714-1830
Regency 1830-1837

small glass pieces only

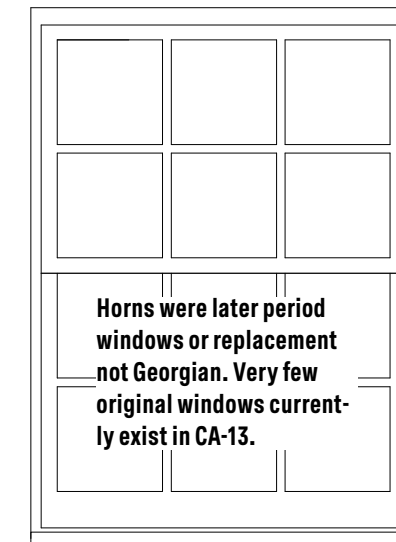

slim profile, cavity, evacuated sash
6 over 6 panes **Double glazed**

Many Manufacturers

Slenderpane
Gowcroft Joinery
Mumford & Wood
Kingsrock Joinery
Energlaze
William Richards Sash Windows
fmcproducts
Timbalite
Histoglass

Distinctive sash

Early Victorian 1830-40s

distinctive mixed glass pane layouts

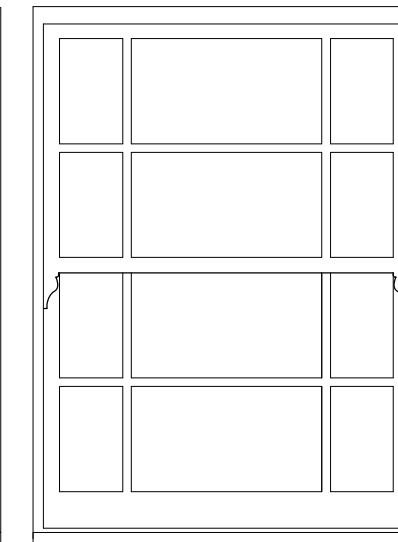

slim cavity or evacuated sash
varied number panes **Double glazed**

Many Manufacturers

Slenderpane
Gowcroft Joinery
WSW Wandsworth
Kingsrock Joinery
Energlaze
William Richards Sash Windows
fmcproducts
Timbalite
Histoglass

Functional sash

Victorian 1837-1901

larger glass sizes with new manufacturing

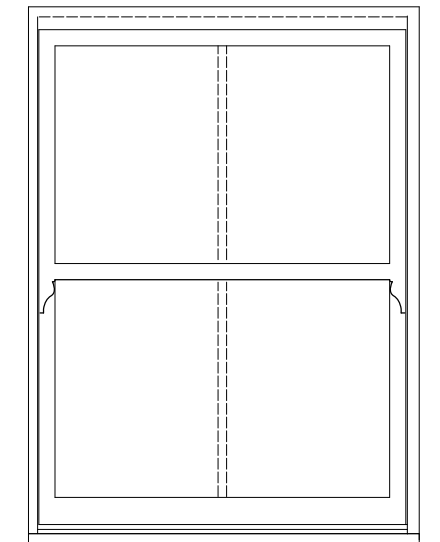

simulated hung or regular hung sash
1 over 1, or 2 over 2 panes **Triple glazed**
or some high spec double glazed

Many Manufacturers

Bewiso
Eksalta
Passisash
Mumford & Wood
Gowcroft



SPD PRINCIPLE Comfort

Replacing windows fixes three things, cold air leaks, cold radiant temp and excessive heat loss through the window saving energy costs, carbon and importantly providing better occupant comfort.

An infrared camera shows surface temperatures of building elements (blue coolest and red warmest).

In the example below left, we see existing single glass surface temperature on the interior of 8.6°C when outside temperature is 0°C and indoor is 21°C. This will result in cold drafts and window damage with moisture condensation on glass and wood frame. On the image below right, looking at the exterior, the windows all appear red to white radiating heat loss to the outside air. Heating system heating the air!

The yellow green area on the lower sash of the left image is indicative of warm air being drawn across the glass surface and drawn out of a leaky window transom. The cold inner glass surfaces make the draughts worse.

Infrared Camera shows problems with single glazing
Winter at 0°C the indoor glass surface was 8.6°C creating drafts.
The UK has the worst performing housing in Europe!

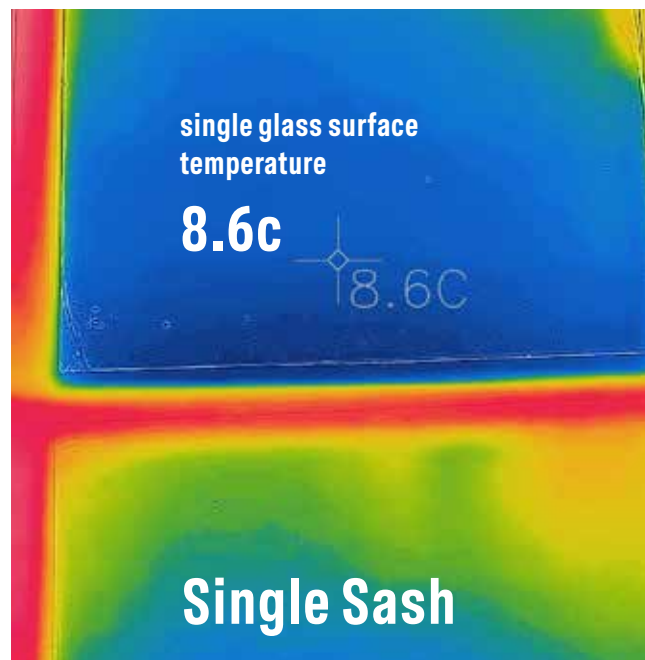

Interior Cross Street. Single glazed window with cold surface of 8.6°C, condensation risk. (blue colder)

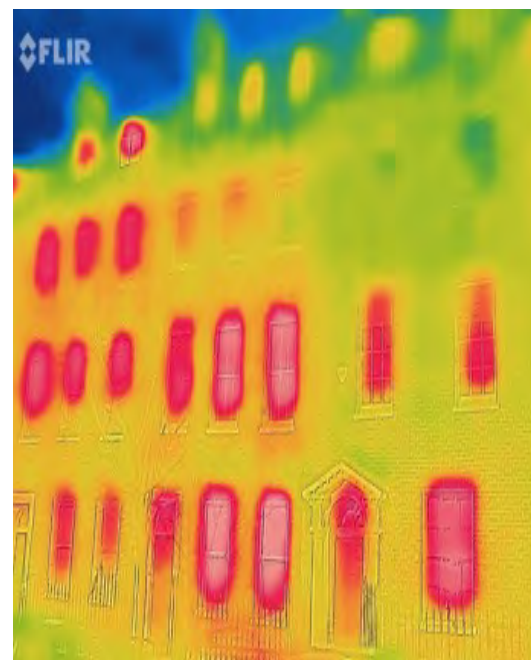

Exterior Cross Street. Single glazed windows with hot surface radiating heat to outside. (red warmer)

SPD PRINCIPLE Replacement

Planning Principles -SIGNIFICANCE

Significance is used to protect later additions. Islington Local Plan 8.25 states, 'Frequently, later historic additions to listed buildings are of significance in their own right as part of the building's history. Generally, later fabric of significance must not be removed in order to restore a building to an earlier form.'

Replacement windows do not form 'fabric of significance'.

They were often cheapest cost (like PVC today) and not changed for aesthetic or heritage reasons. Windows are replaceable without affecting the structure. A significant addition would be a change such as a Victorian Conservatory or an embellished facade such as Sir John Soane Museum, London. **British Standards Publication BS-7913** 2014, section **6.9 Reinstatement of lost features** states, 'replacement might be justified, for sash windows'.¹ and section 6.17 Reinstatement applies when original sash windows have been lost.



Cross Street- rotten, double glazed required



Cross Street- Harmed sash on listed Georgian

HISTORIC ENGLAND view 20 August 2020

'4. Where historic windows have been replaced with ones whose design does not follow historic patterns. These are unlikely to contribute to the significance of listed buildings. Replacing such windows with new windows of a sympathetic historic pattern, whether single-glazed or incorporating slim-profile double-glazing, may provide an opportunity to enhance the significance of the building, which is the desired outcome under national policy.'²



Harmed 1 over 1 windows should be replaced with sympathetic historic pattern 6 over 6 double glazed, Cross Street Listed terrace



Essex Road -Harmed by PVC vinyl casements

¹ <https://www.heritage-house.org/documents/BS-7913.pdf>

² <https://historicengland.org.uk/whats-new/features/climate-change/modifying-historic-windows-as-part-of-retrofitting-energy-saving-measures/>



SPD PRINCIPLE Secondary

Secondary glazing is an old method developed before the current new Evacuated Glass and Slim Profile/Cavity technologies. At that time there were no Insulated Glass Units suitable for heritage sash. Today we do now have alternatives detailed in following pages in this report. These new alternatives should be used for most buildings in conservation areas and those listed buildings with harmed or non-original sash. New Evacuated glass is now used in listed properties such as Winston Churchill's Grade II listed Templeton House.¹

A study in 2011 of residents in Bath, a town noted for heritage as a UNESCO World heritage site, found support from residents and the Bath Preservation Trust for replacing listed building windows with slim-profile (14mm or less) double glazing on rear (private) façades and on front (public) façades if harmed. Eleven years on, the new Slim Cavity and Evacuated glass are even better alternatives.

'Timber slim-profile double glazing is hard to spot. It is ideal for most traditional homes in Bath.'

Warmer Bath: A guide to improving the energy efficiency of traditional homes in the city of Bath, Will Anderson, Centre for Sustainable Energy and Joanna Robinson, Bath Preservation Trust, June 2011

Serious secondary glazing problems.

U-value 2.5W/m²k which is 2x better than single glass but not as good as double

- 1) Harm to interior window joinery or panelling.
- 2) Interior denial of historic look with reflection over glazing bars.
- 3) Difficulties cleaning both window layers. Important if the secondary window uses coated glass for better U-value.
- 4) Effort to open prevents occupant ventilating room.
- 5) Danger lifting heavy sash without balance weights.
- 6) Potential misalignment of bars outer and inner windows.
- 7) Moisture condensation possible damage on cooler outer heritage window as the inner window not sealed to the outer.
- 8) Added double reflection harm seen from outside.
- 9) Aluminium frame embodied carbon vs. replaced wooden sash.

Most often discreet secondary glazing relies on metal. Heavier timber framed secondary glazing or removable (storage issues) secondary glazing that rely on thin magnetic strips may be alternatives to aluminium.

There may be situations where there are original single glazed heritage windows of rarity, detailing, or special listed rating that should not be replaced. In these cases secondary glazing may be the only way to retrofit so care should be taken to address the problems outlined.

¹ <https://gowercroft.co.uk/case-studies/templeton-house/>

² Energy Efficiency & Historic Buildings, Secondary Glazing for Windows, Historic England April 2016

³ <https://www.slenderpane.com/slim-double-glazed-units/acoustic-unit/>



Timber double glazed no secondary reflection within a nearby Islington Conservation Area.

Acoustics

Secondary windows

are known to be good for noise insulation due to the air gap between both sets of windows usually measured at 100mm with no additional benefit after 200mm. This is problematic for heat as the gap should be less than 20mm otherwise a convection current circulates heat and cold across the gap from each window surface.²

Double glazed sound units avoid this convection current as they have small gaps. They use different glass thickness which vibrate at different frequencies and thus reduce sound transmission. A typical slim-profile sound unit will use a 4mm and a 6.8mm stiffer laminated glass layer with a 4mm air space, total 14.8mm.³

Secondary Glazing AUDIT

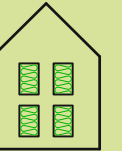

7 of 173 buildings have secondary glazing

Secondary glazing is not popular in CA13.

There are 7 properties with all or partial. Essex Road 5 houses & Cross Street 2 flats which are single floors of two listed Georgian terrace houses. Four secondary glazed windows are casement style behind traditional sash as left and should be replaced Three secondary glazed windows are aluminium matching sash. As a result of the non take up of secondary glazing homes are left with higher energy usage.

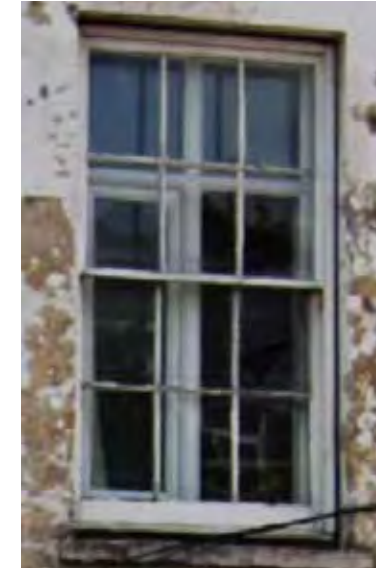

Essex Road, Secondary glazing misalignment harms heritage. London Borough of Islington CA13

1) Slim-profile double glazing should be permitted in listed buildings, where the original glazing is no longer in place. It is recognised that original glazing is deemed important in terms of conservation of historic materials, however in many cases this has been lost, representing an opportunity for thermal improvement without compromising historic fabric'.²

'Double Glazing In Listed Buildings', Project Report prepared by Changeworks for The City Of Edinburgh Council, July 2010
This was a trial installation In Listed Edinburgh Georgian Tenement Block of Slim-Profile panes in existing sash or new sash and one Evacuated Panes.



Secondary window visual impact of reflections on inner secondary windows harms heritage in Conservation Area. Research found by the trial installation of different double glazed unit types in Edinburgh Georgian tenements, by the Changeworks project mentioned above.²

² https://www.changeworks.org.uk/sites/default/files/Double_Glazing_in_Listed_Building.pdf

SPD TECHNICAL Ventilation

Traditional Ventilation - Leaky Buildings

Wind pressure driven air provides a constant air flow entering through gaps in leaky window sash. Originally this was required for heating and lighting (candles) with fireplace combustion also driving the system as heated air rises up chimneys and draws in combustion oxygen. When toilets were moved from out-houses in the garden and indoor plumbing installed a great deal of added moisture needed to be vented. Moisture wasn't expelled passively so additional vents were needed as shown below, causing the house to become more leaky. Furthermore, air drawn up chimneys by combustion was reduced when burning firewood and coal was banned in UK smokeless zones, with the Clean Air Act 1956/1993.

Combustion for lighting was replaced with electricity but heating, hot water and cooking still used combustion gas instead of wood or coal fires. Gas combustion and moisture in buildings needed extract fans as draughty or open windows were not sufficient particularly as houses started to insulate in the 1970's. These exhaust fans require open vents as intakes with gaps under doors allowing constant flow (drafts) through house.

EXAMPLES in CAT3



Cross Street- Listed Georgian



Cross St - New build



Cross Street-nonlisted Victorian



Cross St - Listed Georgian

HOLE in the glass

Round circles cut in window glass with plastic closable vents are unsightly causing harm to heritage windows. Usually found in bathrooms at the rear but these examples found from public street.

HOLE in the wall

Airbricks installed to provide constant flow through walls providing fresh air and oxygen for combustion and moisture venting.



Cross Street-nonlisted Victorian

OPEN window

Exhausting stale or wet air requires enduring cold drafts and occupant involvement with manually opening and closing.



Essex Road, - New build trickle vent slot in top sash

HOLE in window frame

Many recent double glazed windows include trickle vents (slot allowing steady inflow). These are not compatible with heritage detail unless they are concealed in the side frame.

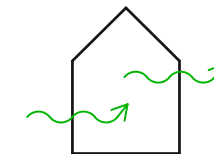

Better Practice -controlled ventilation



COMBUSTION FREE

label for projects with no burning from any source

Heritage 17th & 18th century homes were designed for wood or coal burning with leaky windows supplying air drawn up and out through chimneys. In the 20th century these homes were retrofitted with new technology: electricity replaced candles or gas lighting, indoor loos and baths replaced outhouses, and gas central heating, HW, and cooking replaced wood and coal fires. Many physical changes were made: holes were cut in walls and windows, rear extensions built for bathrooms, floors and walls opened up for wiring and plumbing, and redundant fireplaces and chimneys blocked or removed.

In the 21st century, a second retrofit is underway as we move to clean non-combustion heating sources such as heatpumps and solar generation, high level insulation, and controlled ventilation.

The new **Retrofit Standard PAS 2035**, requires any insulation or airtightness measures (windows) to have the ventilation system assessed and upgraded if needed. The Retrofit Academy¹ publishes guides to the PAS 2035 with a good ventilation guide.² Visible vents will still be needed in heritage buildings but some systems like the MVHR can employ single rear facade or roof vents rather than multiple through wall vents.

TYPICAL TYPES OF CONTROLLED VENTILATION

Current typical

Intermittent extract ventilation (IEV) system consisting of fans in all wet rooms and background ventilators (to admit fresh external air) in all living spaces and bedrooms.

like Current but runs continuously low level

Decentralised mechanical extract ventilation (dMEV) system consisting of fans in all wet rooms which run continuously at background level instead of intermittently and have intermittent boost, with background ventilators (to admit fresh external air) in all living spaces and bedrooms.

like Current but does not use electricity

Passive stack ventilation (PSV) system consisting of passive stacks up through roof extracting air from all wet rooms and background ventilators (to admit fresh external air) in all living spaces and bedrooms.

Quieter system because one remote extract fan

Centralised mechanical extract ventilation (cMEV) system that extracts moist stale air from all wet rooms via ducts to one central larger fan combined with background ventilators (to admit fresh external air) to all living spaces and bedrooms.

Quiet system heat exchange preheat but needs ducts to all rooms

Mechanical ventilation with heat recovery (MVHR) whole-house supply and extract continuously extracts moist stale air from wet spaces to preheat fresh air to provide warmer air to living spaces and bedrooms. It is difficult to retrofit ducting. LETI suggestion using visible ducts run in stair halls may be practical, publication 'Retrofit, How Many How Deep', coming out in 2023.³

Fan or PSV controlled cold air intake.

Best, air preheated, no cold air intake.

¹ <https://retrofitacademy.org/what-is-pas-2035/>

² <https://retrofitacademy.org/ventilation-guide/>

³ <https://www.leti.uk/publications>



SPD TECHNICAL 1 for Georgian & Distinctive windows

Slim-Profile glazing is defined as any thickness of 14mm or less. Ten years ago, Slim-profile were promoted as they satisfied heritage visual requirements. Many councils allowed timber slim profile to replace windows for non listed buildings and sometimes listed buildings as Wirral Council Port Sunlight. The window shown on the opposite page has Slim Profile double glazing; it would be very difficult to tell from a historic sash, because the only external difference would be the bevelled putty. Many early 18th to late 19th glazing bars shown below are impossible to match exact width, 16-19mm. Bars a few mm wider but made to exactly the same style, such as the ovolo and fillet shown below, might be acceptable if the difference in width is not apparent.

In terms of performance, the seal sight lines of 5mm are less than standard double glazing of 8-10mm as they are narrower to fit glazing bars. This can cause failure with Argon/Krypton gas leak and moisture ingress through the sealant layer. If Slim-Profile windows are used they should meet British/ EN 1279 parts 2 & 3 European Construction Products Regulations.¹ and ²



Distinctive Victorian
36/34 Cross Street wide glazing bars which could take sealed double glazed units mounted into this original timber sash, or see page 88 vacuum glass.

late 17th - 18th Century Glazing Bar

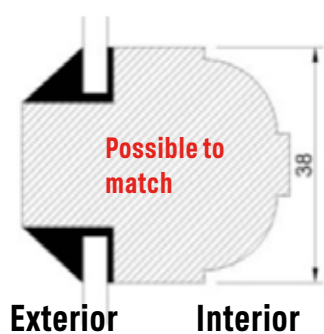

early 18th- 19th Century Glazing Bar

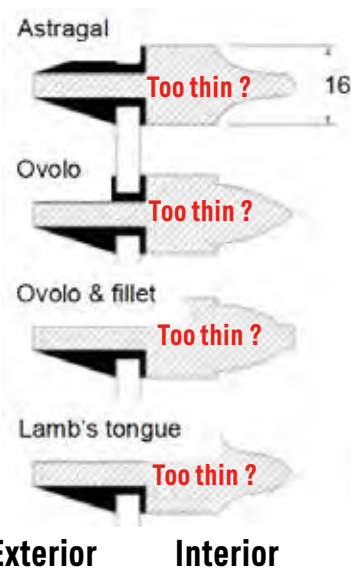

late 19th Century Glazing Bar

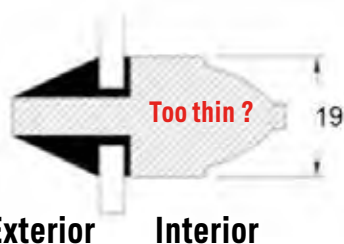

check seal spacer compliance

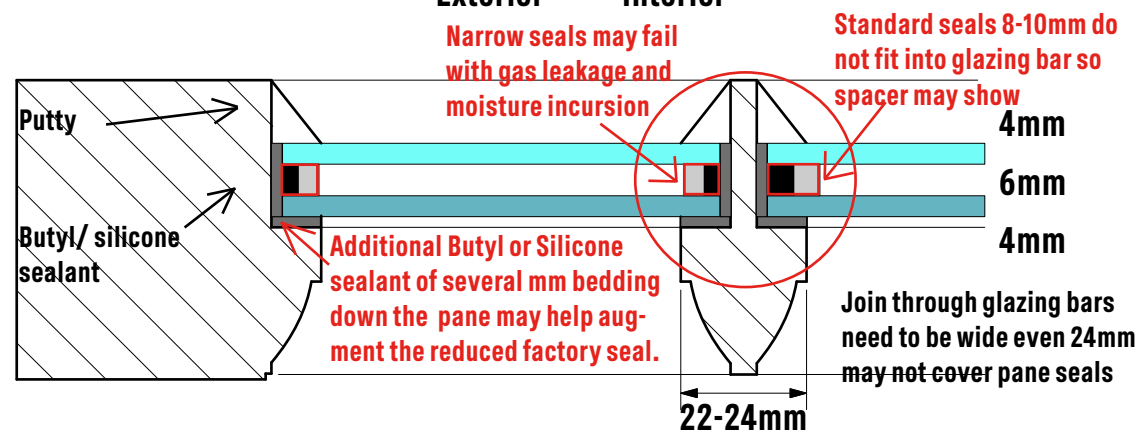

Slim-Profile Detail Plan Section Timber Sash

typical 14mm with 22-24mm glazing bar, Whole window U-value **1.9-2.3W/m²k**

¹ <https://gowercroft.co.uk/news/problem-slim-double-glazing-in-heritage-windows/>
² <https://www.ggf.org.uk/technical-update-cpr-and-insulated-glass-units/>

Slim-Profile -Hung Sash

True 6 over 6 panes double glazed

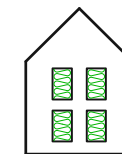

caution check seal spacer compliance

Whole window U-value of **1.9-2.3 W/m²K**,

2021 Bldg Reg is **1.4W/m²k**

2.3x less heat loss than single glazed at U-value 5 W/m²k

Georgian

Timber slim-profile double glazed, replaced window Halton Road Listed house

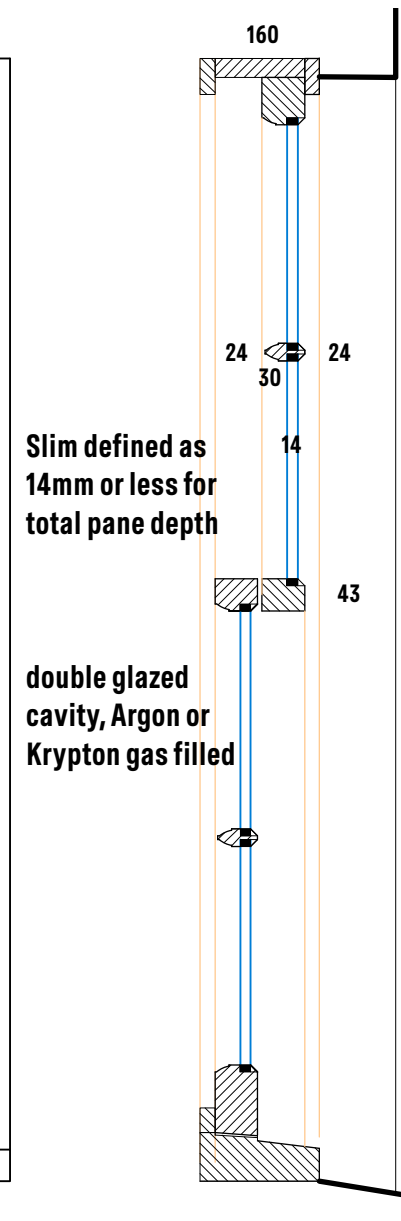
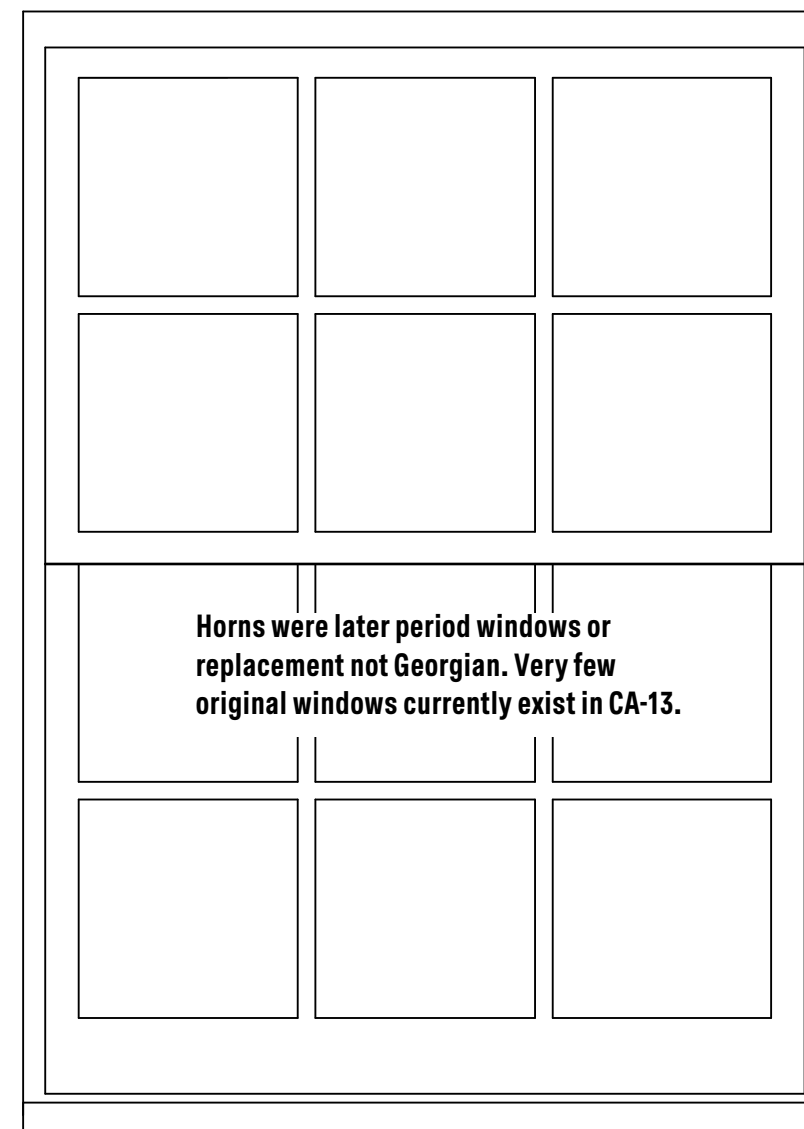

Glazing **BS EN 1279/part 2 & 3 certified**

Edgetech, Super Spacer Heritage, www.edgetechig.co.uk

sightlines good with 3mm spacer depth + sealant, for 4, 6 or 8mm cavity

Thermobar Warm Edge Spacer Tube, Heritage, www.thermobarwarmedge.com

sightlines might be impacted (check manufacturer detail) with 5.5mm spacer depth + sealant, for 4, or 7.5mm cavity

many manufacturers **but check compliance BS EN 1279/part 2 & 3**

Timbalite, Heritage Range, www.timbalite.com Edgetech 4/4/4 or 4/6/4,

Slenderpane, Heritage, www.slenderpane.com Edgetech 4/4/4 or 6, 8, 6.8(acoustic)

Histoglass, Thin Double Glazing, www.histoglass.co.uk uses 7-9mm German seal 1279 certified



SPD TECHNICAL 2 for Georgian & Distinctive windows

An alternative to Slim Profile is Slim Cavity. It has astragal bars on the surfaces of a 1 over 1 window with wider seals only around perimeter hidden in the larger sash frame. Without the many through bars it can achieve better U-Values. It can also match exactly the thin glazing bars, such as are needed in heritage windows.

Although this type of window is better than Slim-Profile it still falls short of current 2021 Building Regs for existing building new elements. Since Conservation have exemption it could be used to match the style of the house. For a better standard (Building Regulations) or new elements in non conservation one would have to use the window on next pages, Evacuated glass.



LB of Islington has allowed replacement of the window above in a non listed building with a Slim-Profile double glazed window. (14 Dagmar Terrace granted approval in 23 June 2021).



Distinctive Victorian
40-52 Cross Street

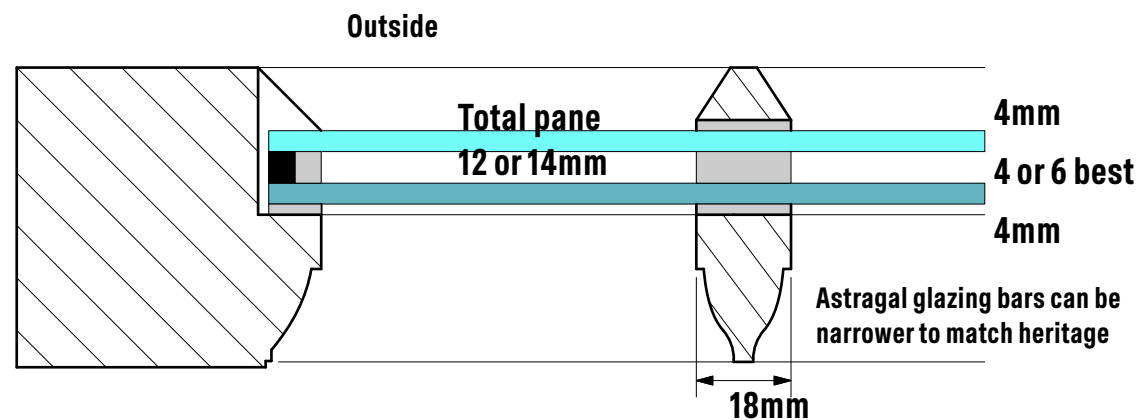

Slim Cavity Detail Plan Section Timber Sash better than Slim-Profile
typical 12-14mm with 18mm glazing bar, Whole window U-value **1.9W/m²k approx.**

Slim Cavity -Hung Sash Astragal Glazing Bar simulated 6 over 6

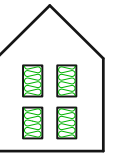

2.5x less heat loss than single glazed window at U-value 5 W/m²k **recommended**
Whole window U-value of **1.9 W/m²K**, 2021 Bldg Reg is 1.4W/m²k

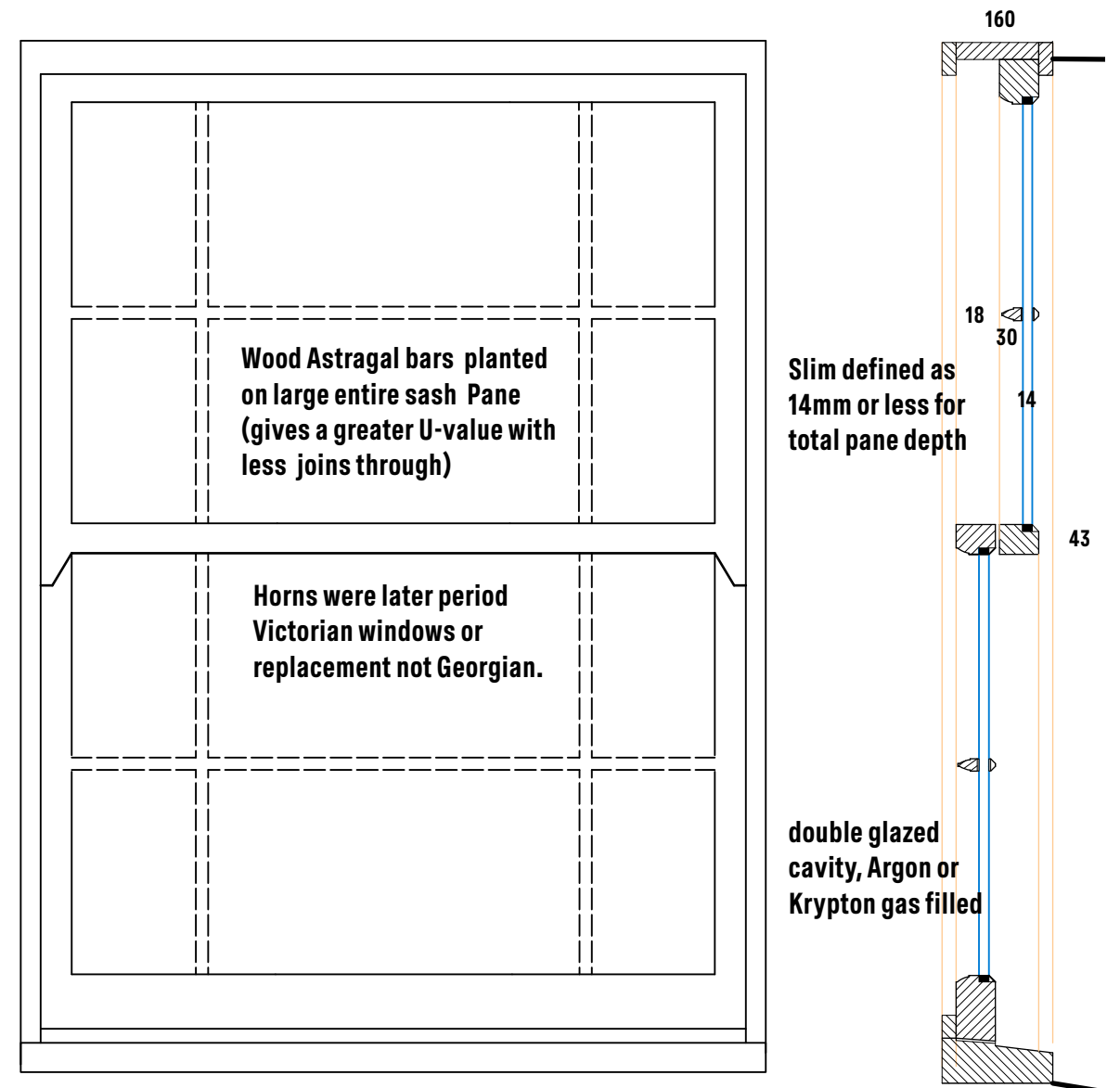

details from Manufacturer Mumford&Wood

some Slim Cavity manufacturers

Astragal glazing bars 18 or 22 mm. Whole Window U-value (glass, frame, and seals) from manufacturers to be checked

Mumford & Wood, Conservation Range, www.mumfordwood.com glazing 10 year warranty
18 or 22mm plant on glazing bar, 4/6 krypton/4mm, Spring or box sash whole window U-value 1.9W/m²k

William Richards Sash Windows, 4/8/4, 4/6/4, or 4/4/4 whole window U-value 1.9-2.4W/m²k
(18 or 22mm bar) www.williamrichardssashwindows.co.uk

Kingsrock Joinery, Slim profile, www.kingsrockjoinery.co.uk

Bespoke to a variety of specifications.

fmc, fmcproducts.co.uk, Bespoke to a variety of specifications.



SPD TECHNICAL 3 for Georgian & Distinctive windows

2021 Building Regs

Element type	Maximum U-value ⁽¹⁾ W/(m ² ·K)
Window ⁽²⁾⁽³⁾⁽⁴⁾	1.4 or Window Energy Rating ⁽⁵⁾ Band B minimum.

Building Regulations are getting tighter with each new revision. Currently Slim Profile or Slim Cavity windows do not meet 1.4W/m²k for existing building retrofit. Although there are exemptions in Conservation which allow Slim use, we can use new technologies to meet the regs and anticipate further tightening standards. In Conservation a whole house retrofit approach can rebalance higher specifications to elements to compensate where there are difficulties on other elements.

Newer Technologies such as Evacuated Glass are promising developments. Evacuated panes are two glass layers with a extremely narrow vacuum gap of 0.2mm or 0.3mm held apart with tiny black dot spacers which are barely noticeable. One plug where it was evacuated will be visible at one corner. Edges are sealed with less leakage failure and longer lifespans than slim-profile spacers. Technological breakthroughs by LandVac allow the use of toughened glass which the older original Pilkington/Nippon glass manufacturing process could not use.

The entire window can be replaced **or the sash and weights only** with weather stripping brushes and proprietary gaskets to address the sash window inherent weakness versus hinged windows.

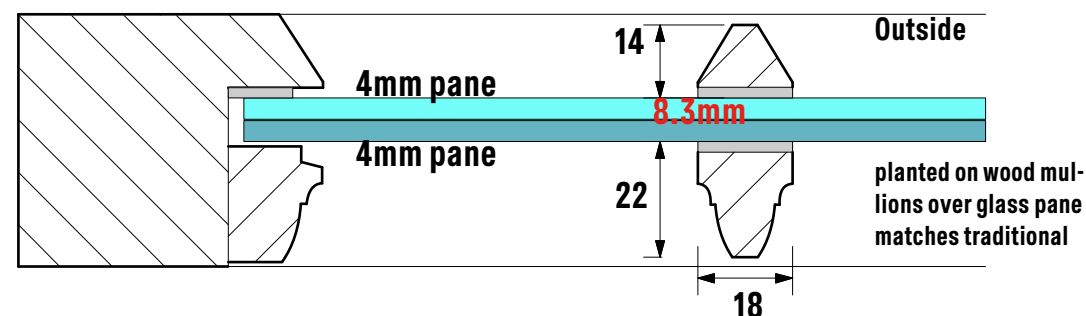

Evacuated Pane Detail Plan Section Timber Sash

LandVac 8.3 glass on Gowercroft Sash, Whole window U-value **1.2 W/m²K**

Evacuated Glass Manufacturers

U-values of glass much lower, not the required Window U-value which is glass, frame, and seals

Pilkington Spacia™, the original Japanese Evacuated Glass, not available in the UK.

<https://www.pilkington.com/en/global/products/product-categories/thermal-insulation/pilkington-spacia>

Fineoglass, Belgium, available 6.7mm (two 3mm)

<https://www.energlaze.co.uk>, <https://www.fineoglass.eu/ultra-thin/double-glazing>

LandVac, Chinese toughened glass as standard available in 8.3mm (two 4mm), also available other sizes including 10.3mm (two 5mm) & 12.3mm (two 6mm) and others

https://www.landvac.net/vacuumglass/glasslist_one.html

Guardian, American, 8.3mm (two 4mm), 24mm (4/12/4/0.3/4mm) triple glass

www.guardianglass.com/gb/en

Evacuated Pane -Hung Sash

Astragal Bar simulated 6 over 6 panes

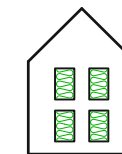

4x less heat loss than single glazed window at U-value 5 W/m²k **highly recommended**

Whole window U-value of **1.2 W/m²K** surpasses Building regs. (Gowercroft Winston)

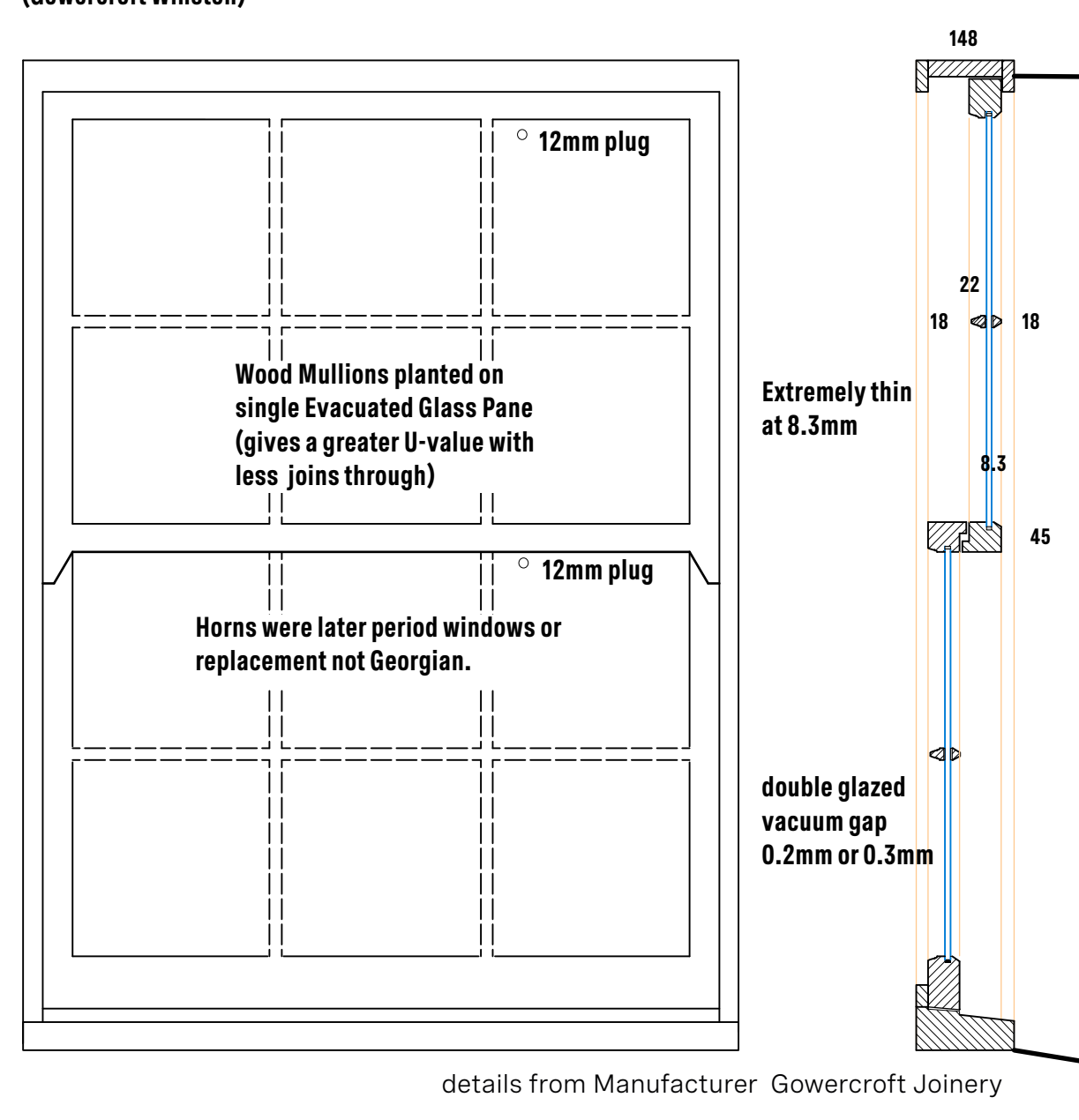

some Evacuated Glass Window Manufacturers

Whole Window U-value (glass, frame, and seals) check with manufacturers

Gowercroft Joinery, Heritage Range Winston, www.gowercroft.co.uk

As LandVac is weld-sealed, there is no gas leakage so its energy efficiency does not diminish with time. 8.3mm overall. Used in Winston Churchill's Grade II Listed Templeton House. Whole window U-value **1.2W/m²k**

Energlaze, www.energlaze.co.uk, also WSW Wandsworth, www.sashwindows.london

uses Fineoglass 6.7mm uses Fineoglass different thicknesses

Kingsrock Joinery, Sash, www.kingsrockjoinery.co.uk

uses LandVac.8.3mm

William Richards Sash Windows, www.williamrichardssashwindows.co.uk

uses LandVac 8.3mm 18-22mm plant on astragal bars, U-value **1.2W/m²k** ? hasn't been tested



SPD TECHNICAL 4 for Functional Victorian windows

Current Building Regs are getting tighter (and energy costs higher) so in order to future proof one can look at existing higher standards such as EnerPHit passivhaus at 0.8W/m2k. Victorian large 1 over 1 windows go toward these higher standards with triple glazing but sash still have draft gaps. Two companies below address this which improve overall U-values. Gowercroft with clamped seal at mid rail and Bewiso with clamp of entire bottom sash against fixed top and frame.

Gaskets on midrail compress on patented seal to deliver Class 4 air permeability standards on all sash windows

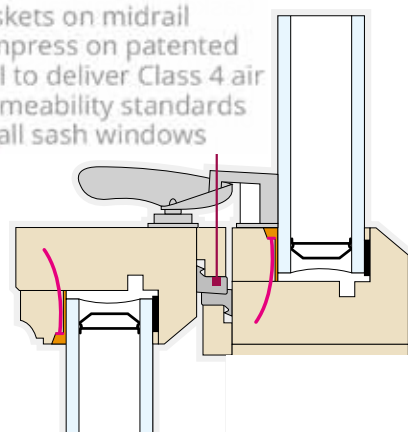

Gowercroft Classic mid-rail sash detail clamps top and bottom sash together against gaskets to seal draft gap.

Bewiso George solves the sash gaps with a clamp that pulls the entire bottom sash against gaskets in frame and fixed top sash for a seal more like casement hinged windows.

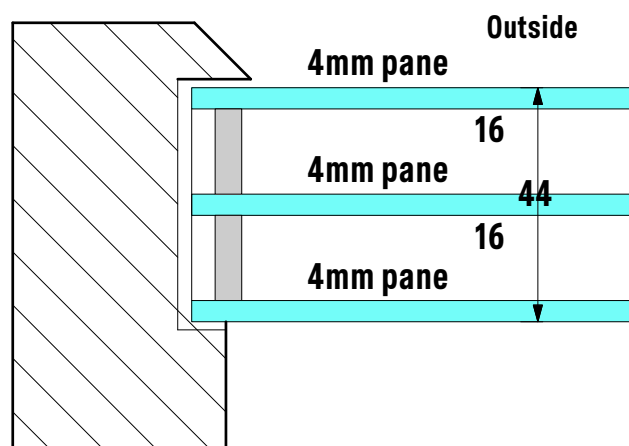

BEWISO -Detail Plan Section Triple Glazed Sash

Bewiso, model -George, 4/16/4/16/4mm, Whole window U-value **1.0 W/m²K**

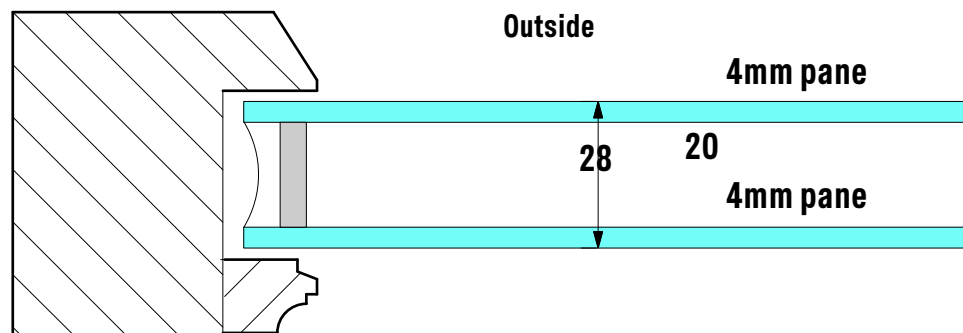

Gowercroft -Detail Plan Section Double Glazed Sash

Gowercroft, Classic -Chatsworth, 4/20/4 mm, Whole window U-value **1.3 W/m²K**

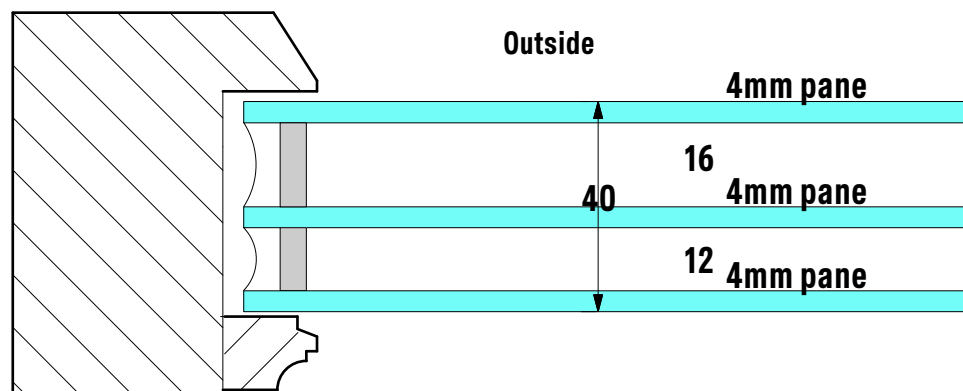

Gowercroft -Detail Plan Section Triple Glazed Sash

Gowercroft Classic Chatsworth, 4/12/4/16/4mm, Whole window U-value **1.1 W/m²K**

New Double or Triple -Hung Sash 1 over 1 Timber panes

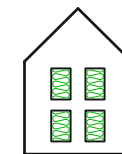

5x less heat loss than single glazed window at U-value 5 W/m²k

highly recommended

Whole window U-values of **1.0-1.3 w/m²K**, surpass Building Regs 1.4w/m²k

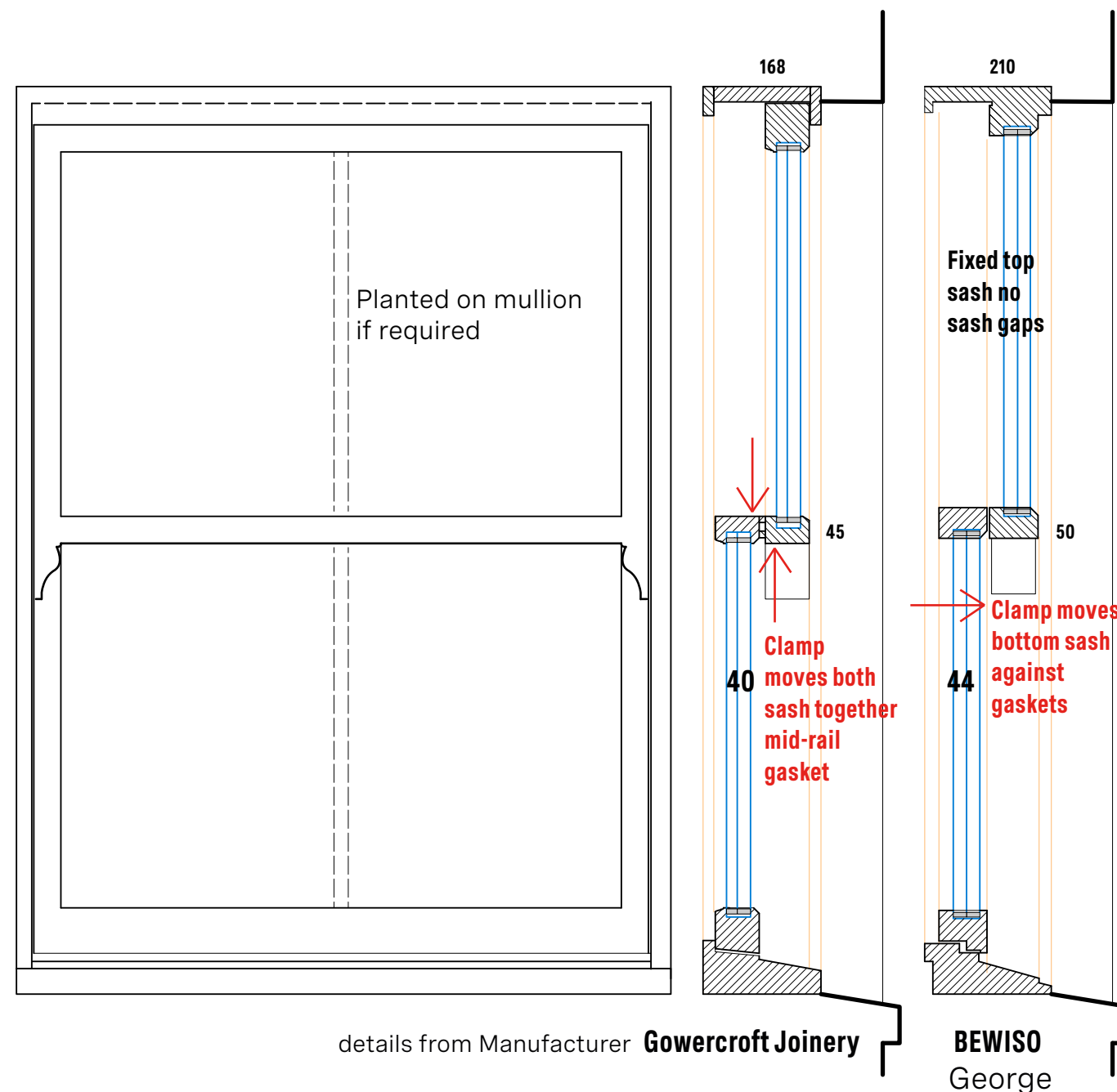

details from Manufacturer **Gowercroft Joinery**

BEWISO George

some manufacturers (all U-values from manufacturers to be checked)

Gowercroft Joinery, Classic Range Chatsworth, triple or double, www.gowercroft.co.uk

40mm (4/16/4/12/4mm) triple glass, BSI Class 4 air permeability standards. triple glazed, U-value **1.1 W/m²k**

28mm (4/20/4mm) double glazed U-value **1.3 W/m²k**

Bewiso, George triple, fixed top sash-lower sash opens, www.bewiso.eu

44mm (4/16/4/16/4mm), Trade marked bottom sash clamps Triple glazed U-value **1.0 W/m²k**



SPD TECHNICAL 5 for Functional Victorian windows

Hybrid

Hybrid (Vacuum glazing mixed with traditional insulated glass) units are currently under development by two glass companies. This promises U-values as good as triple glazing in a thinner pane configuration. Double insulating panes come as standard 24mm thick. These new hybrids are designed for this standard 24mm pane for retrofit replacement or new production. LandVac also supplies thicker units using 5mm or 6mm toughened glass. Gowercroft is introducing a modified LandVac unit for its Tatra Heritage Sash and Acadia casement windows.

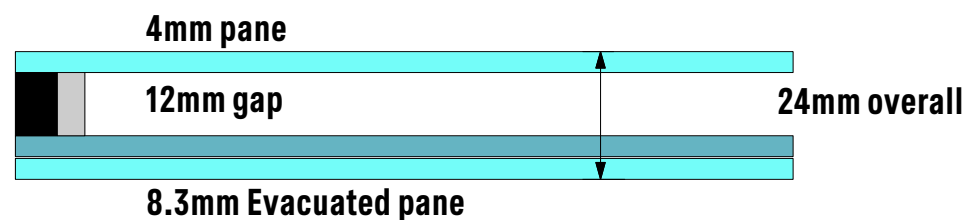

Guardian Vacuum IG Hybrid Detail Plan Section

Under development. Whole window U-value ? W/m²K

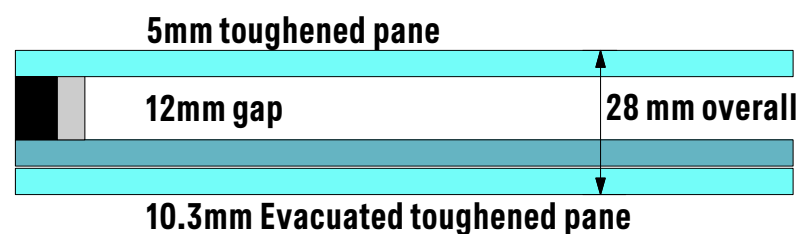

LandVac Vacuum IG Hybrid Detail Plan Section

Under development. Whole window U-value ? W/m²K

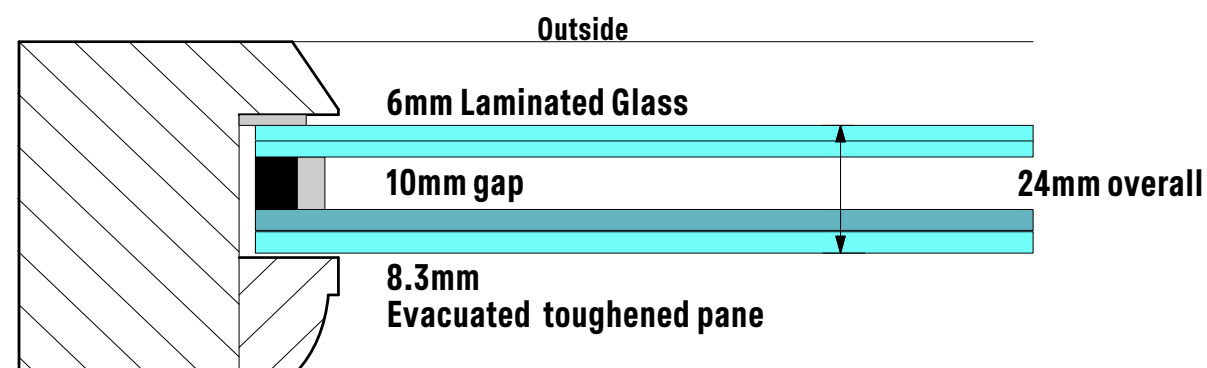

Gowercroft Hybrid-Detail Plan Section Tatra Sash

Gowercroft Frontier Range Tatra, 6/10/4/.3/4mm, Whole window U-value **0.94 W/m²K**

Hybrid Evacuated -Hung Sash

1 over 1 -Timber triple glazed

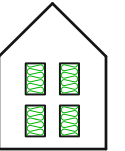

5.2x highly recommended
less heat loss than single glazed window at U-value 5 W/m²k

Gowercroft U-value of **0.94 W/m²K** expected

With similar U-values but glazing depth of only 24mm rather than 40-44mm this could be a good alternative to triple glazing.

Product Series	Product Configuration	U-value (W/m ² -K)
Energy saving Series	5TL +0.3V+5T	0.45
Energy saving Series	5TL +0.3V+5T	0.5
Energy saving Series	5TL +0.3V+5T	0.45
Energy saving Series	5T+12A+5TL+0.3V+5T	0.44
Energy saving Series	5T+12A+5TL+0.3V+5T	0.48
Energy saving Series	5T+12A+5TL+0.3V+5T	0.44

Thermal Insulation

Product	Visible Light %	Reflectance (Out % / In %)	U-Factor	R-Value	Solar Heat Gain Coefficient
Guardian Vacuum IG					
8.3mm Thickness, Low E coating #2 on #3 surface, 4mm/3mm gap/4mm					
VIG - 70/36	70%	11/12	0.089	11.3	0.372
VIG - 62/27	62%	11/12	0.085	11.8	0.265
Guardian Vacuum IG Hybrid					
10.3mm IG Unit, Low E coating #2 & #4 surface, 4mm/10mm air space/4mm/3mm gap/4mm					
VIG - 70/36	54%	13/15	0.071	14.1	0.265
VIG - 62/27	42%	13/14	0.068	14.6	0.180

The performance values shown are nominal and subject to variations due to manufacturing tolerances. Guardian performance data are calculated for center-of-glass only (no spacer or framing) in accordance with the LDNL Window 7 program. Guardian reserves the right to change product performance characteristics without notice or obligation.

This chart shows the two IGU configurations that lead to R-14 thermal performance for a VIG, in this case from Guardian Glass. Note how incredibly thin the IGUs are (with a gap between the panes of glass just 0.3 mm and very thin tempered glass).

Image: Guardian Glass.

LandVac

Guardian figures in Imperial measures as is US product.

some window manufacturers (all U-values from manufacturers to be checked)

Gowercroft Joinery, Frontier Range Tatra Sash, hybrid vacuum, www.gowercroft.co.uk

24mm (6/10/4/0.3/4mm) toughened glass unit, BSI Class 4 air permeability standards. triple glazed, U-value **0.94 W/m²k**

some glass manufacturers developing these

Guardian, American, www.guardianglass.com/gb/en

24mm (4/12/4/0.3/4mm) glass unit (R14 imperial), U-value **0.4?W/m²k**

LandVac, Chinese, www.landvac.net/vacuumglass/glasslist_one.html

28mm (5/12/5/0.3/5) toughened glass, U-value **0.44 W/m²k**



SPD TECHNICAL 6 for Functional Victorian windows

A traditional vertical sash window will never be able to achieve air tightness and durability found in modern hinged windows that clamp tight firmly against several gaskets. The modern insulation of triple glass is another problem for vertical sliding hung sash due to the added glass weight. Some manufacturers do make triple glazed vertical hung sash for small windows with spring sash but the weight can be problematic for larger ones, or using weights which reduce U-value in frame cavity.

The simulated sash window uses the European TILT-TURN system, essentially an inward opening casement and bottom hung in one. The hinged opening means the windows clamp tight firmly against several gaskets. This innovative passivhaus certified window is designed to match heritage sash. The bottom window is recessed behind the top panel exactly as heritage sash windows and impossible to tell apart, see lower photo NYC heritage Neighbourhood.



Exterior - Simulated Hung sash
Bewiso Victoria - cert. 0.8w/m²K

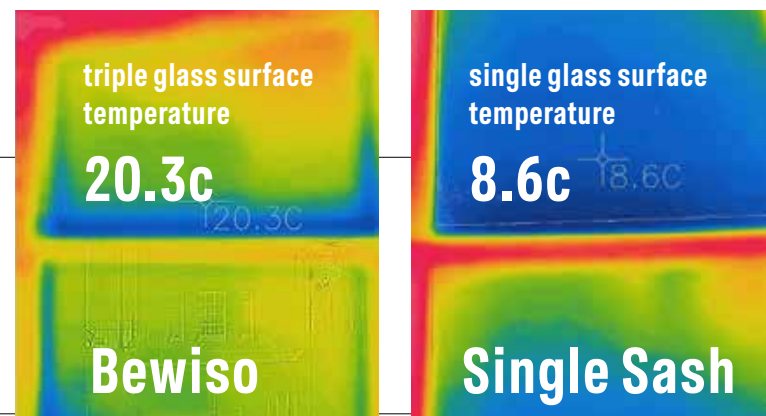

Infrared Camera interior, outdoor temp 0c and indoor temp 21c

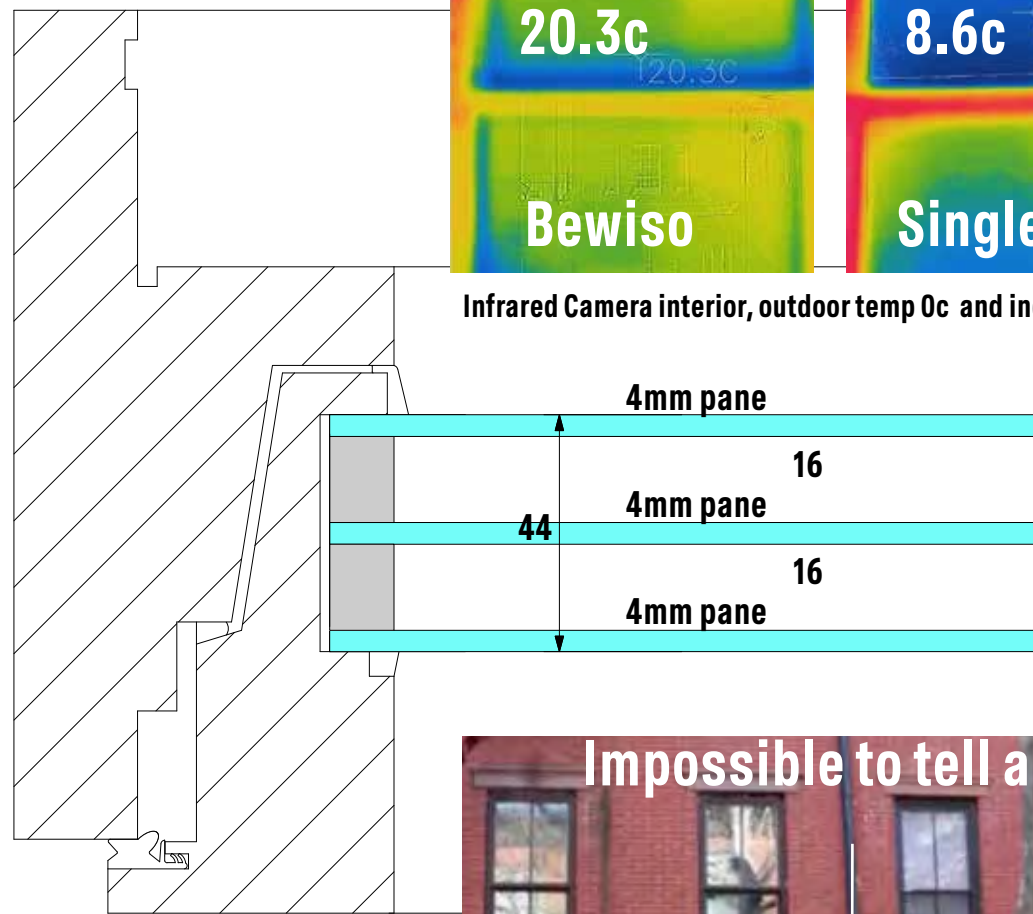

Bewiso -Detail Plan

Victoria, Whole window

U-value 0.8 W/m²K

video <https://www.youtube.com/watch?v=GcbtPxRFzY&t=2s>

Simulated Hung Sash

1 over 1, 2 over 2 (with Astragal bar) triple glazed

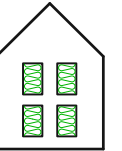

These are best for the functional Victorian style or later periods with a single pane sash or a 2 pane sash for future proofing beyond current Building Regs. or will compensate for other hard to retrofit building elements.

highly recommended
Best available now

6.25x less heat loss than single glazed window at U-value 5 W/m²K
Bewiso, Passivhaus certified whole window U-value of 0.8 W/m²K

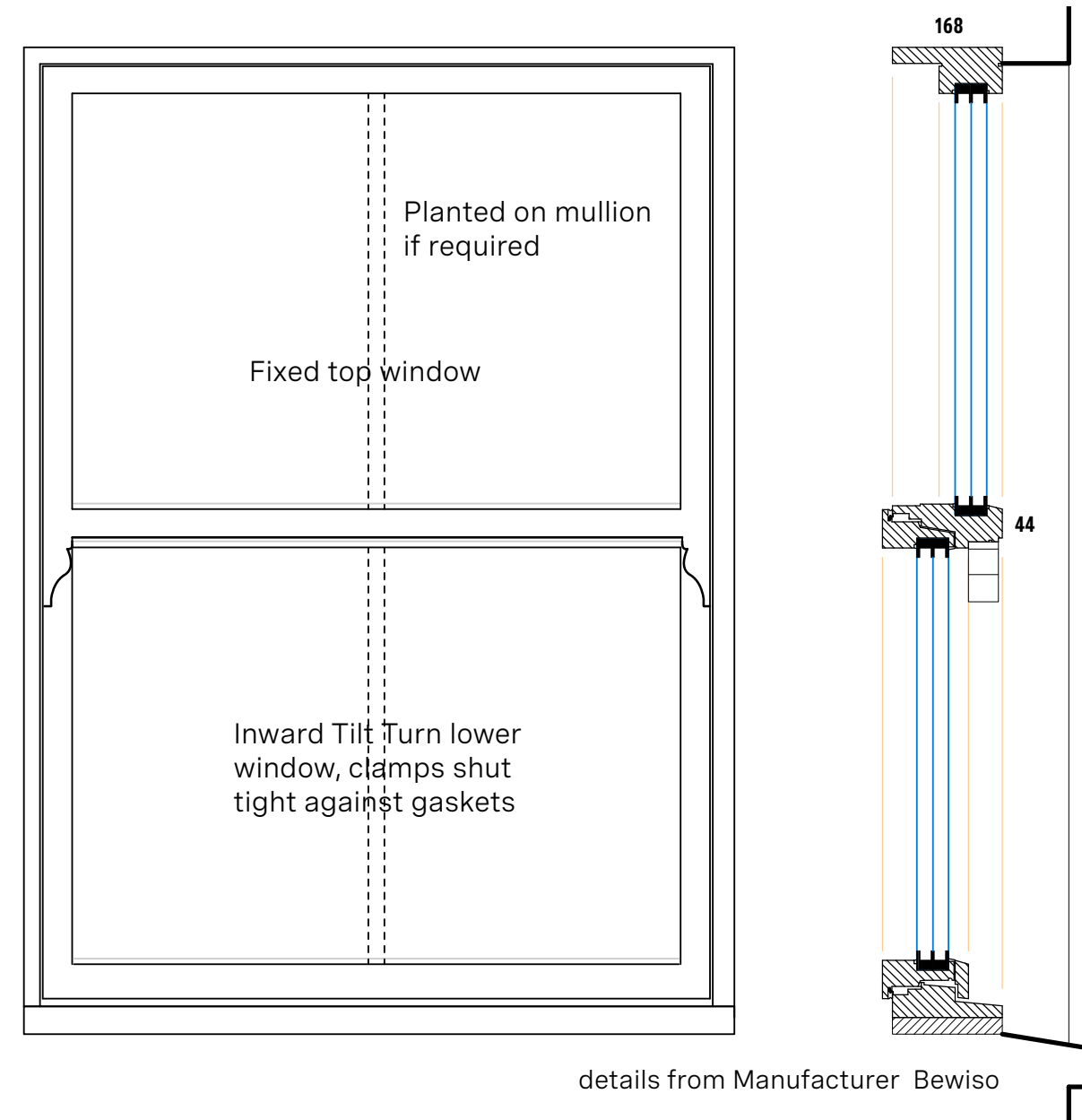

This window type needs to develop and expand into the market Simulated Sash manufacturers -some no longer available
(all U-values from manufacturers to be checked)

Bewiso, model Victoria, Passivhaus Certified, 0.8 W/m²K, www.bewiso.eu

Eksalta, model VictorianSASH, 0.8 W/m²K, www.eksalta.co.uk

Passisash, sash lookalike, 0.9W/m²K,

www.specifiedby.com/enhabit-limited/pasisash-triple-glazed-sash-lookalike-windows



SPD TECHNICAL 7 for Modern Casement windows

History - Post War Private or Social Housing Types

Post war social housing was often built quickly with cheap materials and poor detailing. Although a modern steel 'Crittall' window was used, the configurations reflect medieval cottage casements and small top hung vents. This pattern did not fit with the large Georgian and Victorian sash of the area nor did it reflect the best of international modernist and art deco building which used the Crittall steel window with composed horizontal mullion patterns.

These steel windows are prone to mould and condensation forming on the cold frame which mandated the urgent need for replacement. White clumsy PVC vinyl windows were the cheap fix which further damaged the heritage area. Windows have evolved and best practice today can provide comfort with an aesthetic match of larger casements for heritage areas. www.crittall-windows.co.uk

Original 1950-60s

- 'Crittall' Steel Frame
- Single glass
- Very slender sections
- Paint varied colours

problem-condensation mould on cold frame, steel cold bridge, single glass



Nearby across Essex Road



4 Dagmar Terrace

1st Replacement 1980s

- Vinyl PVC
- Double glass
- Wide sections, white

problem- ubiquitous WHITE, frame widths don't match original and heavy for Conservation Area with delicate Georgian sash, visible ventilation slots making frames thicker



1-16 Fircroft House, Halton Rd



Nearby Florence Street

2nd Replacement 2000s

- Metal clad
- Double glass
- Better section widths
- Larger fewer windows
- Dark colour blends in

problem - not consistent colour of window frame and painted surround, visible ventilation slots



Nearby Florence Street



Nearby Florence Street same building above, replaced vinyl window

Casement -timber or metal clad timber triple glazed (or future quad glazed)

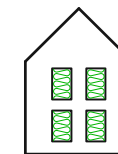

6.25 x less heat loss than single glazed window at **U-value 5 W/m²k**

highly recommended

U-value of 0.8 W/m²K

Best Contemporary practice 2020s

- Timber/metal clad Frame
- Triple glass
- Very slender sections
- Dark colours
- Large openings
- No draughty vents (ventilation through MVHR, mechanical heat ventilation recovery)



new developments Alpen quad glass - inner layers w film or thin glass. www.thinkalpen.com



Building nearby outside CA 13



Building nearby outside CA13



Eterno- casement triple glazed thin 81mm meeting

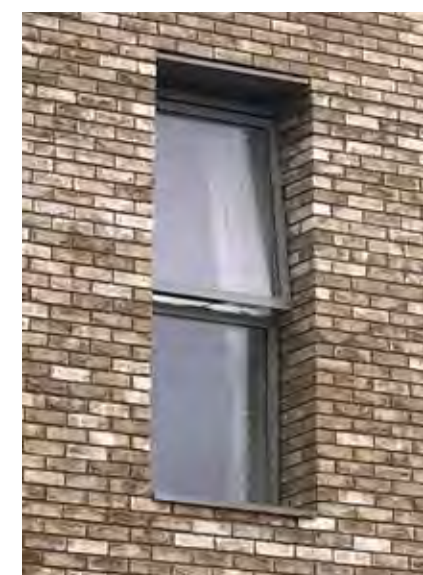

Building nearby outside CA13



Eterno inside view casement doors

Many Manufacturers

Eterno, Ultra slim model Offline, www.eterno-uk.com

Rational, Aura triple, www.rational.co.uk

Velfac, slim frame 200 triple glazed, www.velfac.co.uk



WINDOW SUMMARY

75%

130 (of 173 Buildings)
Propose Double/Triple Replacement with;

Double Slim or Evac.

37 listed Georgian
27 distinctive Victorian

64 Total buildings

Double/Triple Glazing

48 func. Victorian (incl. 4 bad)
18 modern (incl. 5 bad double)

66 Total buildings

14% now

24 (of 173 Buildings)
Existing Double Glazed

2 listed Georgian
2 distinctive Victorian
10 functional Victorian
10 modern

24 Total buildings

There is a misconception that you can't replace single with double glazing in Conservation Areas with an Article 4 direction as shown by low 14% coverage in Islington CA13. Through careful analysis of each window type through window Element Audits the percentage of double glazing can be increased to 89% in CA13. Non-listed building window replacement is accepted practice and listed building windows can also be replaced if they are causing harm or not original as shown by this research.¹ Replacing damaged and incorrect window types enhances the significance of heritage as per national policy.

The oldest listed window sash have been replaced once or many times. Few if any, of the listed buildings in CA13 have original windows

(as is clear from their Victorian style horns).

When windows were harmed they were not replaced with like for like. Incorrect Georgian property sash could be suitable for sensitive six over six double glazed replacements. Some unusual Victorian sash should not be replaced, but energy savings can be achieved with replacement of single window panes with Slim or Evacuated glass panes in these, or by introducing Secondary glazing.

¹ Approval for complete timber replacement at 14 Dagmar Terrace (23 June 2021).

up to **15%** of heat loss, windows are easier to retrofit than other elements.

3%

6 (of 173 Buildings)
Propose Replacement Panes only on a case by case basis or, Secondary Glazing.

Heritage Sash to remain

6 Total. Listed Library, 43/45 Cross St Former Pub, 34/36 Cross St, 12 Fowler Rd Hall, Little Angel Theatre & Workshop.



8%

13 (of 173 Buildings)
Propose Replacement Non Original Sash only on a case by case basis or, Secondary Glazing.

Heritage Sash to remain, Non Original might be replaced case by case

13 Listed Georgian

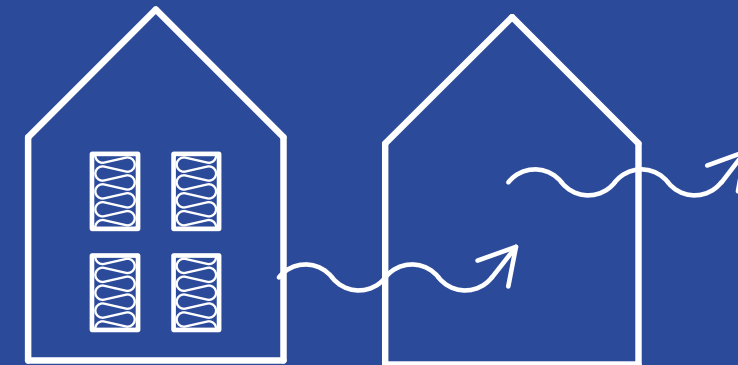

RECOMMENDATIONS

1. Make a clear list of harmed listed buildings and all non listed buildings suitable for upgrading of windows, in CA Guidance Appraisal Documents.

See Islington CA13 example on pages 166 & 167.

2. Develop all local window types with suggested detail drawings, ventilation standards, and update-able manufacturers list in SPD. Local lists will identify National government support needed for research and up-scaling of window manufacturers.

3. Enact an immediate halt to Approval of PVC windows because it is a fossil fuel product with manufacturing and end of life disposal problems. In CA13, PVC windows were approved on (9 July 2021) at 67-69 Essex Road.

2.5.5 External Wall Insulation

'Put on a warm jumper.'

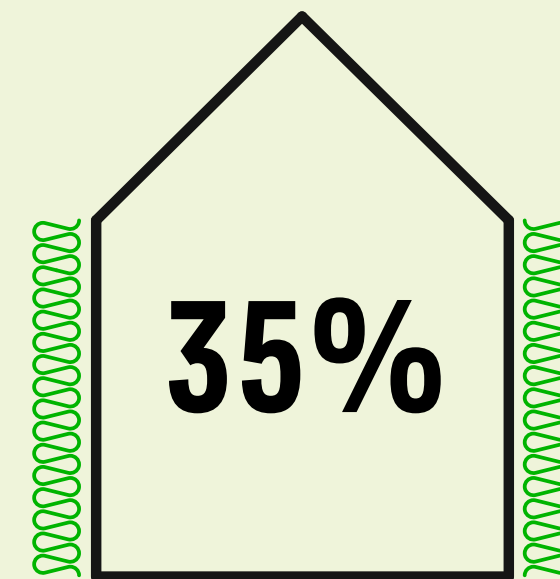

wall heat loss as a
percent of total house¹

¹ Figure of 35% is from, 'Reducing carbon emissions and adapting to climate change in historic buildings', Islington Guide for Residents

AUDIT External Wall Insulation

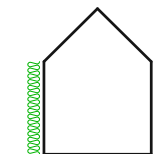

Close to 100% of the 173 buildings in this CA are solid brick walls. This type of structure can be insulated either by external or internal insulation to the walls. Internal Wall Insulation (IWI) is disruptive to occupants, reduces floor space, involves removing/relocating architectural trim such as architraves and cornices, costs more, and is difficult to make continuous at floor or roof junctions. The last point is the real problem as these areas can become thermal bridges attracting moisture condensation, damp and mould. External Wall Insulation (EWI) avoids this as it goes over these junctions, but can mean loss of decorative facade detailing. It is not disruptive to the occupants. For a heritage area an audit can be made to determine which façades can be externally insulated and which not by using the principles of public realm shown on the next two pages.

A study of residents in Bath, a town noted for heritage as a UNESCO World heritage site, has found support from residents and the Bath Preservation Trust for external insulation.

For LB of Islington CA-13 walls have been mapped with a surprising linear percentage of 44% found to be appropriate for External wall Insulation.



A very good guide to EWI was produced in 2015 by Bristol City Council ¹

Render
colour on
Cross Street



Consider other render colour options to compliment local brick less maintenance than traditional off white

‘Around 35% of a home’s heat is lost through the walls.’

From Islington Guide, Reducing carbon emissions and adapting to climate change in historic buildings, Islington Guide for Residents

‘Although exterior insulation is obviously not appropriate for the prominent façades of the buildings of Bath, there are many secondary façades that are either hidden or of little importance to the character of the city.’

Will Anderson, Centre for Sustainable Energy and Joanna Robinson, Bath Preservation Trust, June 2011

Bath Preservation Trust position
The Trust only supports the installation of external solid wall insulation in listed buildings in Bath on secondary façades which are, or have been, rendered.

Joanna Robinson, Bath Preservation Trust, June 2011



SPD PRINCIPLES Public/ Private Realm

Planning Principles - PUBLIC REALM

The Public Realm is the street space we all navigate. It is how any conservation area is perceived. UK planning makes a distinction between public and private realm. The conservation area is for the protection of the public realm, here shown in green. The private realm is the unseen rear back gardens here shown uncoloured white or blue page opposite.

In this worked example as stated previously the CA boundary is porous at 4 points which does not protect the visual continuity of the heritage area. Those areas are shown as dotted extensions.

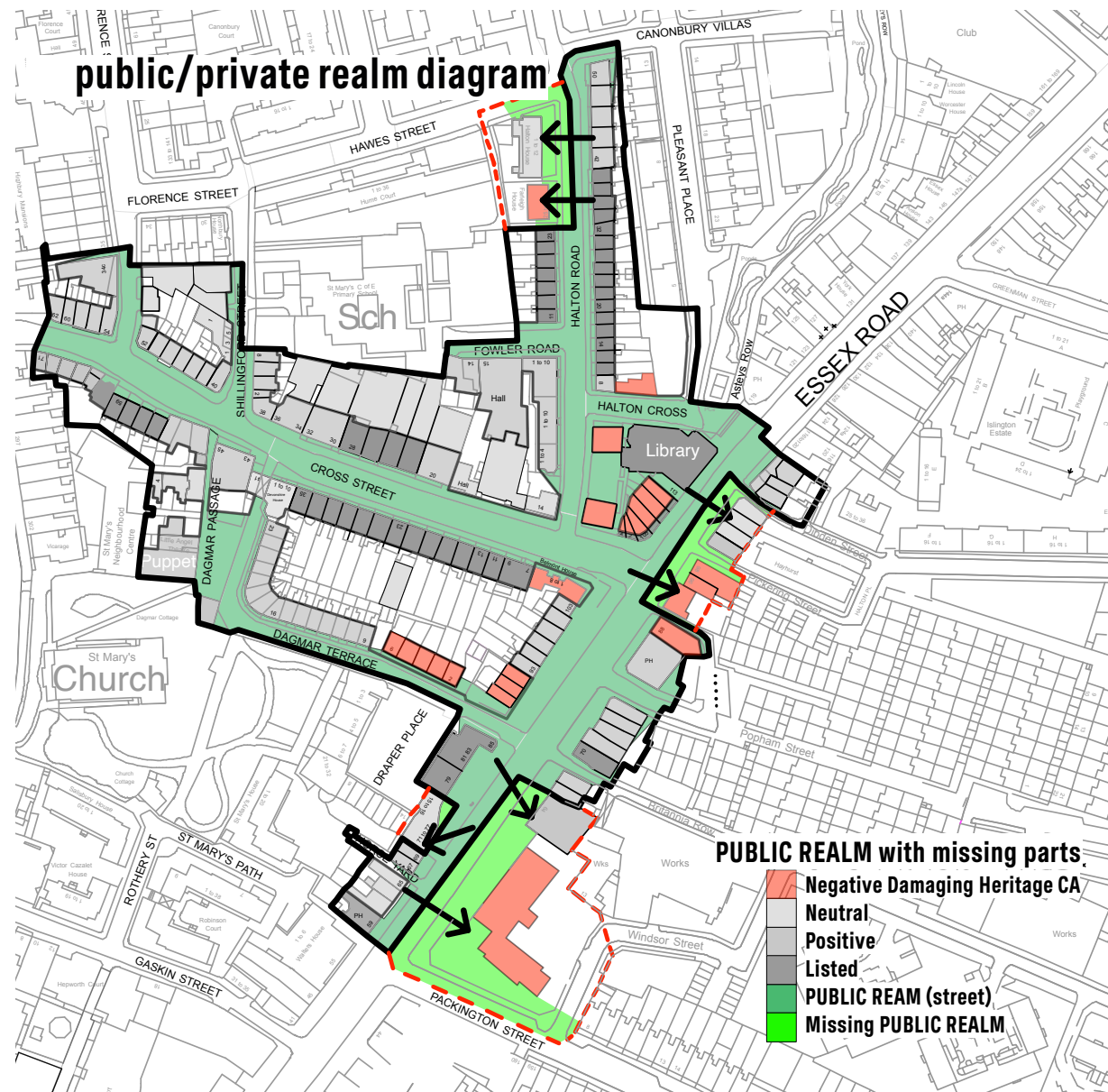

Public Realm Map - ACAN worked example London Borough of Islington CA13

Insulation Strategies Conservation Areas based on Building Audit Categories

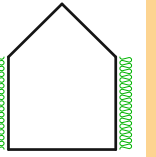

Unconstrained



Unconstrained / Mixed Constraint

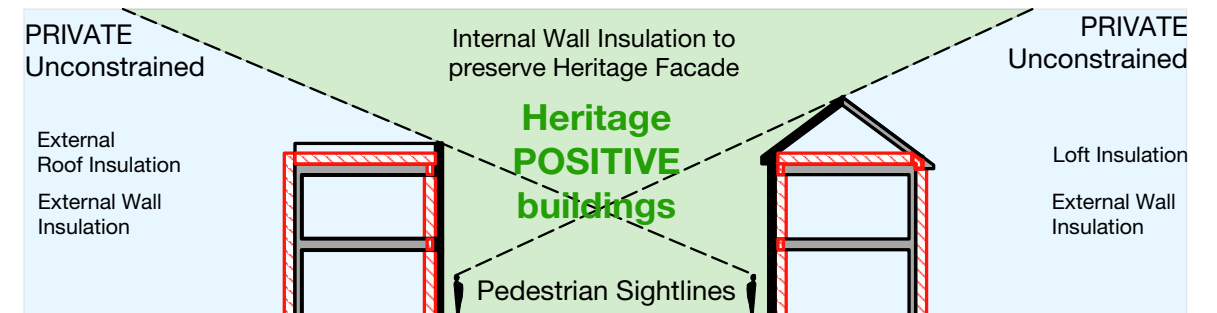

Mixed Constraint



Constrained / Possible Mixed Constraint



AUDIT External Wall Insulation mapping

44% of walls, are not heritage constrained

Negative buildings,
Neutral buildings,
Existing rendered façades,
Rear extensions, and
Rear façades not visible

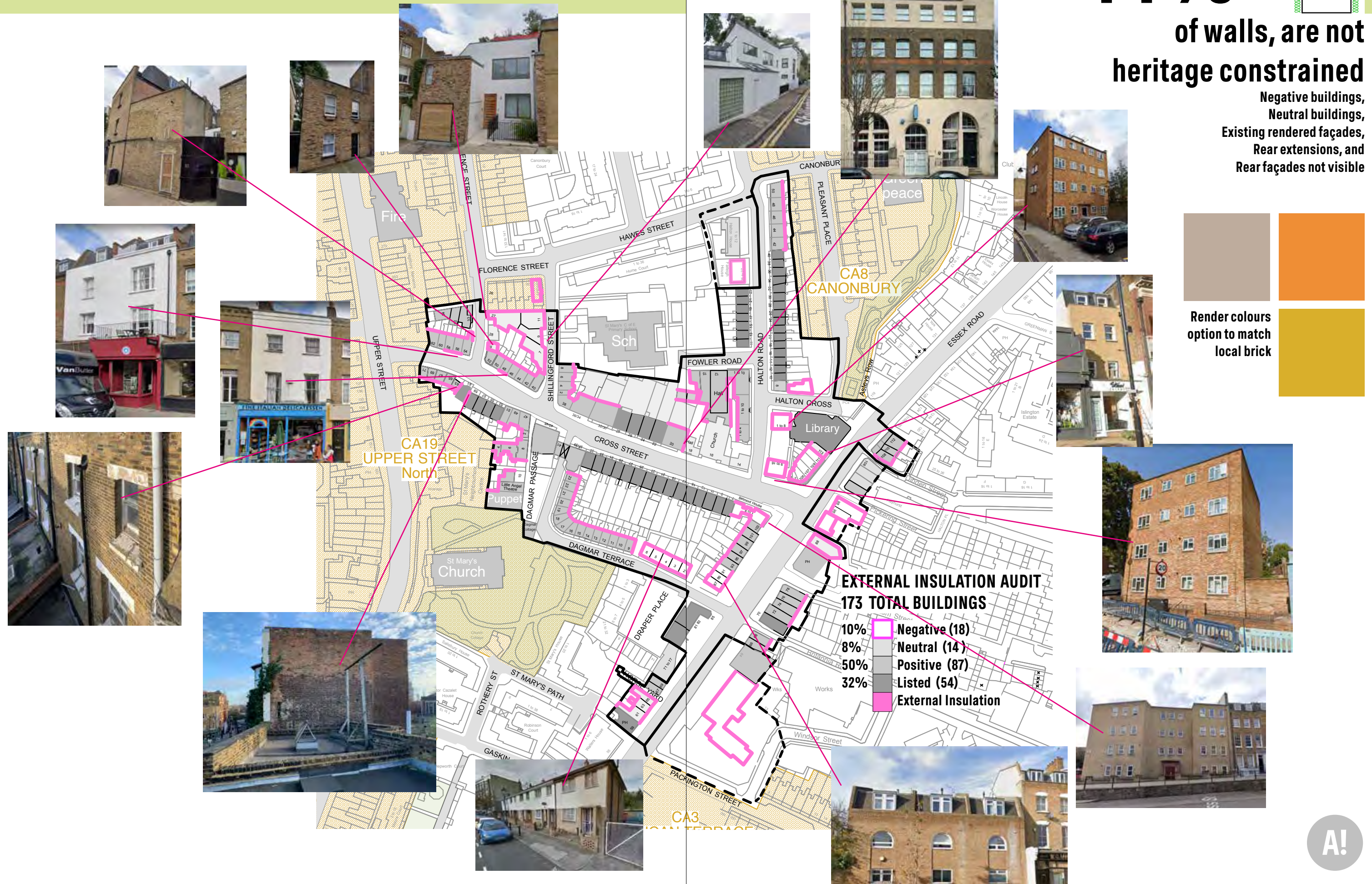
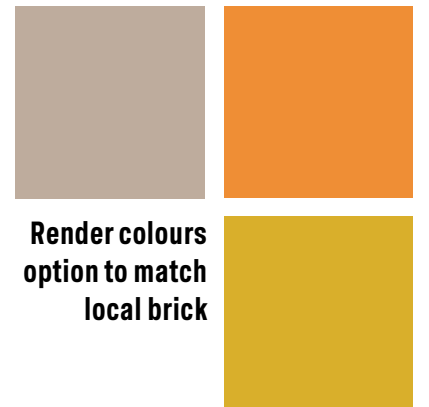

SPD TECHNICAL

Insulation Considerations

Moisture in buildings can result in mould, damp, and fabric decay, therefore in traditional buildings external wall Insulation (EWI) is best to be moisture open; this allows any trapped water to evaporate through to the outside. That said, some moisture closed systems can be suitable with carefully designed junctions at cold bridges and Mechanical Ventilation Heat Recovery (MVHR) but best used only for new construction extensions. Natural insulation products such as woodfibre or hemp wick water better than moisture open glass and mineral fibre products. The exterior render also needs to be moisture open such as lime based renders, which also shed surface water.

There are many growing options with some manufacturers listed opposite page. Care needs to be taken at junctions such as: windows, under roof eaves (which may need to be extended), and at ground. Manufacturers have details for these as shown on the following pages. Georgian and Victorian buildings typically have windows set 100mm back from the outside brick surface. As the wall will increase in thickness 100-150mm, replacement windows can be set to the outside brick surface at the insulation interface.

The new 2021 Building Regs for existing walls call for 0.30w/m²K U-value whereas new walls would be 0.18w/m²K. It might be good to go beyond Building Regs to 0.18w/m²K existing walls and 0.15w/m²K on new walls. A renovation retrofit might have both existing and new walls if a new storey or extension is added. As energy prices increase, 150mm minimum to 200mm or greater should be a goal. This should be decided on a case by case basis. Where space is available higher levels of insulation may be desired to balance out areas where retrofit is more difficult such as the front facade where Internal Wall Insulation must be limited to 0.35w/m²k due to moisture risk.

Render is usually white as is the case with Prewett Bizley's Midmoor Road, image right, to reflect light into narrow passage. Other colours can be interesting such as the darker brick toned colours which blend the new work into the heritage brick work as shown at Cross Street front lower ground well. This darker colour would not need the frequent repainting as white would. Where EWI & render project out a stone coping would be a better transition detail.



2011 North London Retrofitted Houses 4 with External Wall Insulation, (Numbers 2, 7, 13, 14)

Hawthorne Road, Haringey, London, (no7 on map) Anne Thorne Architect, External Wall Insulation EPS



Midmoor Road, Balham London 2011, Prewett Bizley architects
Rear of House, External Wall Insulation +200mmEPS

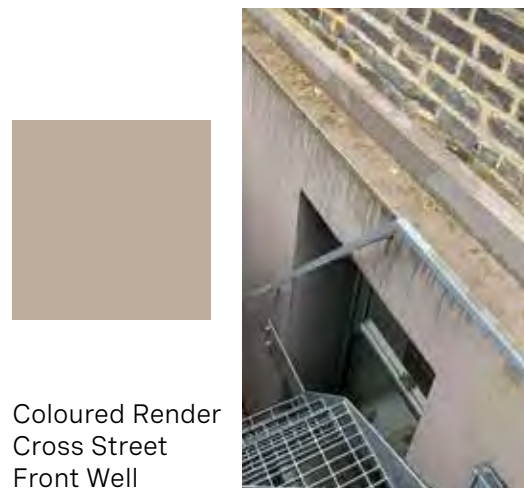

Coloured Render Cross Street Front Well

MANUFACTURER LIST

with approximate insulation thickness for 2 standards to be checked with manufacturers

all U-values are w/m²K

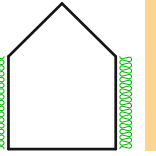

0.18 U-value Thickness New Walls Building Regs	0.30 U-value Thickness 2021 Existing Walls Building Regs	Moisture open vapour breathable External Wall Insulation (EWI)
240mm	140mm	WOODFIBRE natural low carbon footprint, good moisture wicking Unger-Diffutherm, UdiReco-uneven masonry, www.unger-diffutherm.com Steico, Steico Protect Dry, www.steico.com Pavatex, Pavawall, www.pavatex.com Gutex, Thermowall -Wood fibreboard, www.gutex.co.uk
240mm	140mm	HEMP or other natural fibres, natural low carbon footprint Hemspan, Bio Wall- Hemp fibre boards, www.hemspan.com Hemp Block, Hemp Blocks, www.hempblock.co.uk Isohemp, Hemp blocks, www.iso hemp.com
220mm	110mm	MINERAL FIBRE long lasting, better U-value , less wicking than natural Rockwool, External Wall DD Slab, www.rockwool.co.uk Knauf Insulation, Rocksilk EWI Slab, www.knaufinsulation.com Permarock, External wall Insulation Systems, www.permanrock.com
200mm	100mm	EPS Expanded PolyStyrene, vapour perm through small gaps in foam beads Jablite, External Wall Expanded PolyStyrene, www.jablite.co.uk
170mm	80mm	GPS -graphite EPS, vapour perm through small gaps in foam beads Licatatherm, Graphite Expanded PolyStyrene, www.licataltd.co.uk Neopor, Graphite Expanded PolyStyrene, www.neopor.com
140mm	60mm	Moisture Closed not recommended for historic solid wall EWI May be used on new construction extension walls or roofs PIR/PUR polyisocyanurate Saint Gobain, Cellotex , www.saint-gobain.co.uk
140mm	60mm	Phenolic Foam Kingspan, Kooltherm K5, www.kingspan.com



Woodfibre External Wall Insulation i Mineral wool External Wall Insulation install.

<https://www.knaufinsulation.co.uk/products/rocksilk-ewi-slab>

<https://www.rockwool.com/uk/products-and-applications/product-overview/cladding-solutions/ewi-slab/?selectedCat=downloads>



SPD TECHNICAL Woodfibre EWI

Existing Wall Upgrade **0.30w/m²K U-value**. Building Regs 2021, 140mm woodfibre
Better approach if there is space 0.15-0.20 w/m²K U-value, 240mm+ -

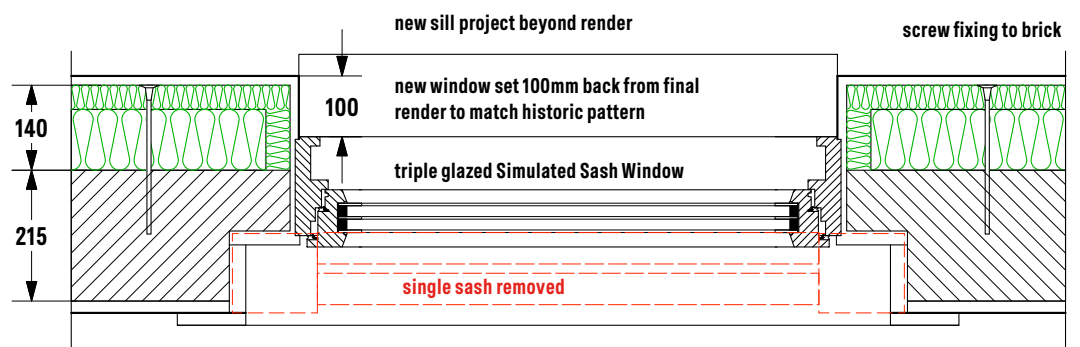

WINDOW DETAIL through lower sash

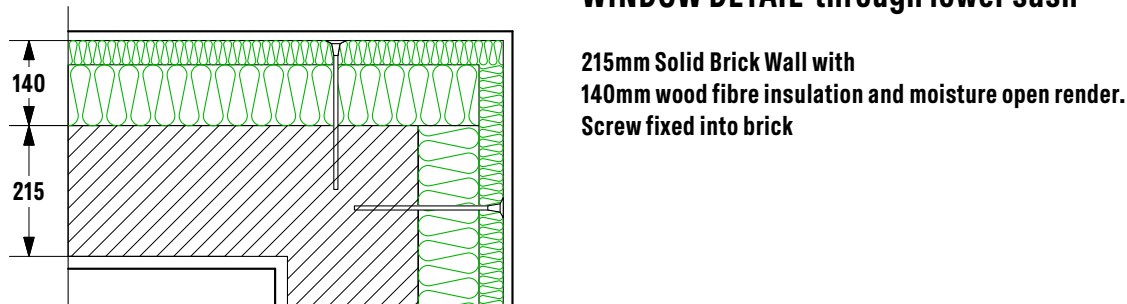

CORNER DETAIL

215mm Solid Brick Wall with 140mm wood fibre insulation and moisture open render. Screw fixed into brick

hard woodfibre layer to take render
soft woodfibre layer to flex with uneven brick



UdiRECO® SYSTEM for masonry buildings

- 1 UdiRECO® Wood-fibre insulation element
- 2 UdiFOUNDATION COAT
- 3 UdiREINFORCEMENT Strengthening mesh
- 4 UdiPERL® Fine structured render
- 5 UdiFOUNDATION COAT
- 6 UdiREINFORCEMENT Corner Protection Profile
- 7 UdiBASE® Plinth-End Cap Profile variable
- 8 UdiASSEMBLY® SDM RECO (Adjustable fixing – Masonry)
- 9 Perimeter insulation with UdiPlinth sealing slurry and plaster coating
- 10 Masonry substrate plastered / unplastered

UdiRECO® SYSTEM

The wood-fibre, external thermal insulation composite system – with integrated levelling compensation

<https://www.udidaemmsysteme.com/product/insulation-boards/udireco-insulation-board-with-levelling-compensation/>

Mineral fibre EWI 'Knauf' & 'Rockwool'

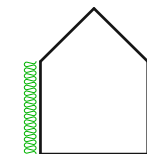

Existing Upgrade **0.30w/m²K U-value** Building Regs 2021, 110mm mineral fibre
Better approach if there is space 0.15-0.20 w/m²K U-value, 220mm+ -

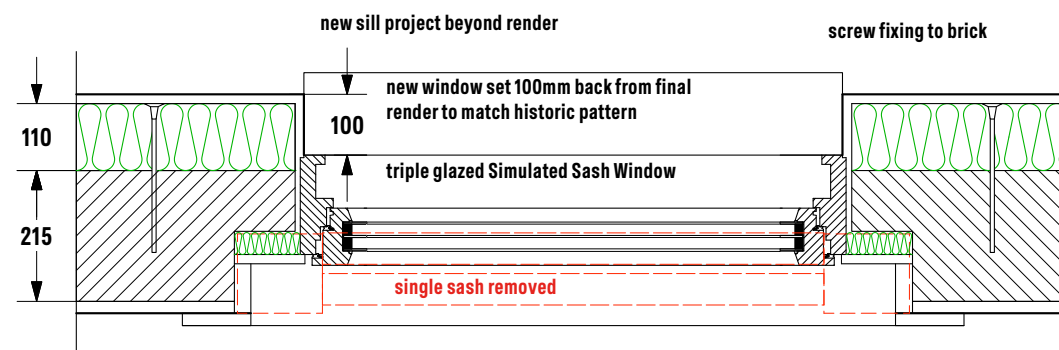

WINDOW DETAIL through lower sash

215mm Solid Brick Wall with 110mm Mineral Wool insulation and moisture open render. Screw fixed into brick

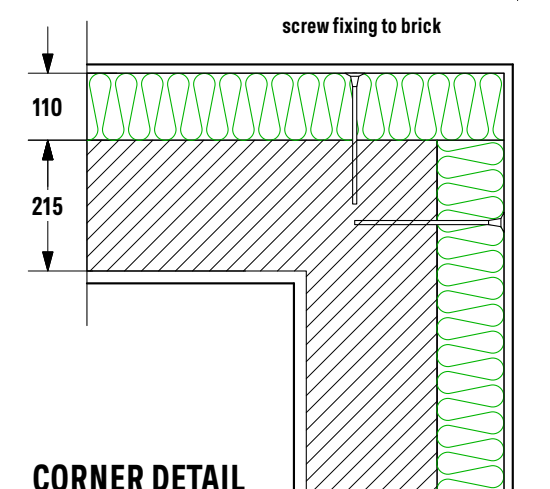

CORNER DETAIL

215mm Solid Brick Wall with 110mm Mineral wool insulation and moisture open render. Screw fixed into brick

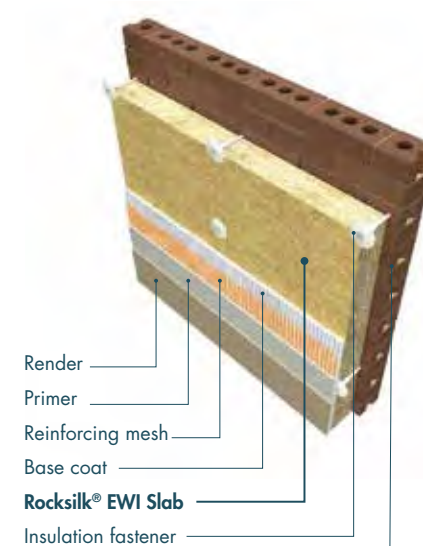

KNAUF Rocksilk EWI Slab

TYPICAL U-VALUES

USING ROCKSILK® EWI SLAB – REFURBISHMEN

Thickness (mm)	U-value (W/m ² K)
	225mm solid brick wall (0.77 W/mK)
200*	0.17
180*	0.18
160*	0.20
140*	0.23
120	0.26
100	0.31

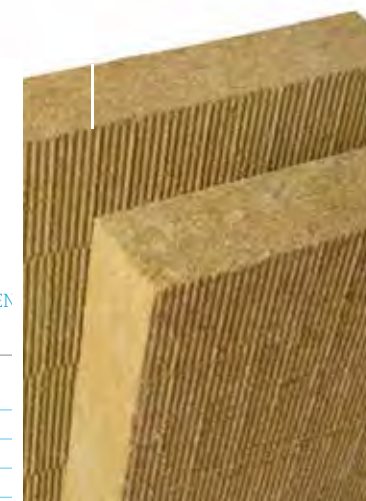

ROCKWOOL External Wall Dual Density Slab

U-values	
External wall slab DD (mm)	Refurbishment: 215mm block*
0.30	110
0.29	110
0.28	120
0.27	120
0.26	130
0.25	130
0.24	140
0.23	140
0.22	150
0.21	160
0.20	170
0.19	170
0.18	190
0.17	200
0.16	210
0.15	220
0.14	240

<https://www.knaufinsulation.co.uk/products/rocksilk-ewi-slab>

<https://www.rockwool.com/uk/products-and-applications/product-overview/cladding-solutions/ewi-slab/?selectedCat=downloads>



WALL SUMMARY

Toolkit Proposed Heritage Constrained

Not suitable for External Wall Insulation. Internal Wall Insulation on a case by case basis.

Interior Wall
Insulation
of Linear Walls
56%



In many Conservation Areas very high proportions of the walls are built from solid brick. However, many of these can meet 2021 Building Regulations insulation standards without harming heritage, typically because they do not face the public realm and are not parts of listed buildings. In particular, they could be given external insulation if they are in the private realm, are already rendered or are parts of negative buildings.

For instance, measurements of wall lengths (but not wall heights) suggest that in CA13 very roughly 44% of walls could be given external insulation. This figure is still surprising as most people would never expect it to be as high in a Conservation Area!

Modern moisture open, External Wall Insulation systems and render are very advanced today. They better protect heritage solid walls through allowing trapped moisture out and by covering most all difficult cold bridge junctions. LETI has recommended 100mm to 150mm, which can meet new 2021 Building Regs U-value 0.30w/m²K. Some projects may want to exceed that if suitable, to compensate for other less insulated areas.

Solid brick walls that could not be given external insulation, might receive internal insulation. In CA13 such walls amount to 56% of the total.

with up to **35%** of heat loss walls are of prime importance to retrofit.

Toolkit Proposed Heritage Unconstrained

100-150mm External wall insulation
minimal thermal bridges at mainly
rear façades

External Wall
Insulation
of Linear Walls
44%



Existing Condition

Uninsulated Solid
Brick Walls with a
few modern
cavity walls

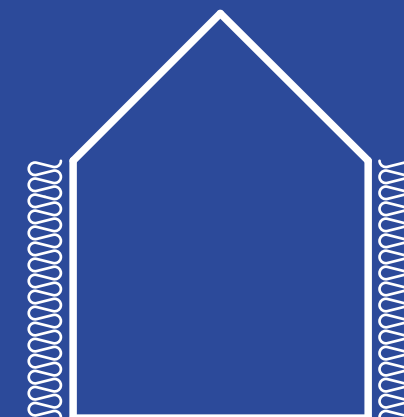

RECOMMENDATIONS

1. Write a Local Development Order for External Wall Insulation with detailed solid wall Insulation methods in the Private Realm and for Negative and Neutral Buildings of Conservation Areas.
2. External Wall Insulation development must follow insulation overlap link (prevention of cold bridge), to current or future roof insulation as detailed in LDO conditional details and SPD general good practice.

2.6.6 Shopfront Facade

'Wear warm leggings.'

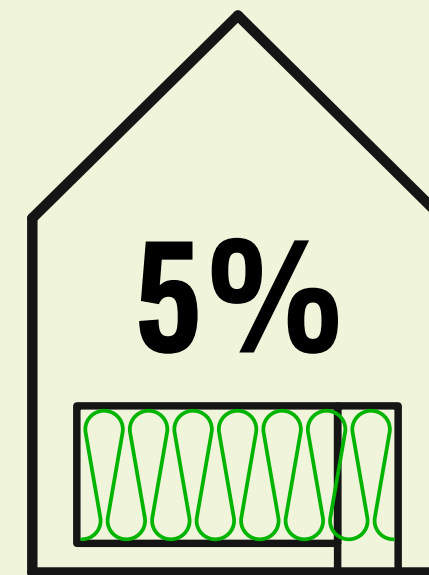

shop window heat loss as a percent of total house.

Figure is much greater as a percentage of the shop.

AUDIT Shopfront Types mapping

This audit has found 56 Victorian shopfronts with more than half of the shopfronts (30) situated within 6 intact complete Parades. The remaining twenty six shopfronts are individual or within broken parades. There are also 4 original workshops (now retail or residential) with extended premises at the rear. None of these were protected in the current 2002 Guidance. Two shopfronts are double glazed, both in residential use.

58 of 60 single glazed

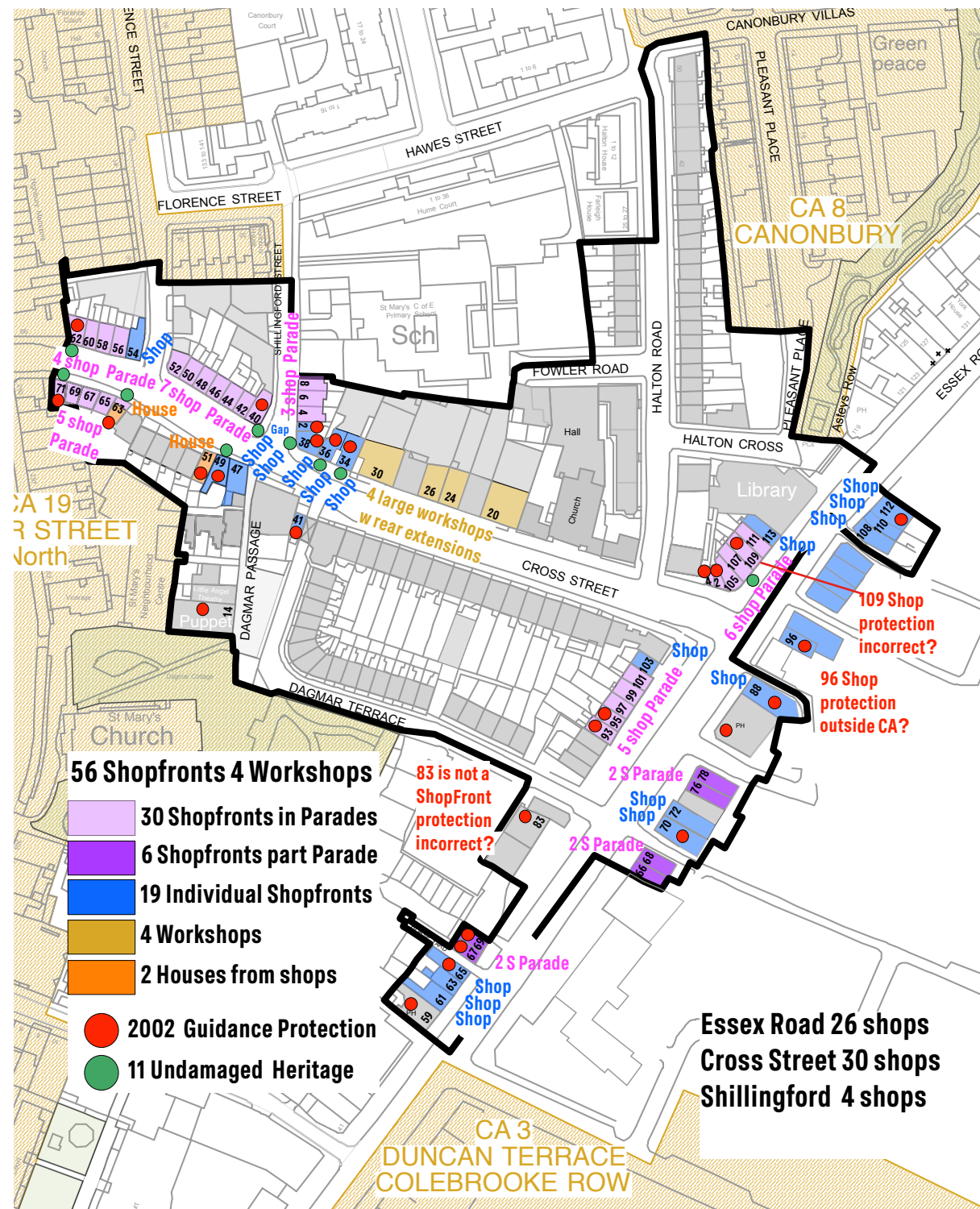

AUDIT Current Practice

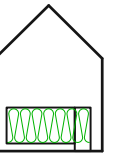

23 of 60 protected shops

37 of 60 unprotected shops

Only 23 shopfronts are protected from removal when all 60 need protection. This study found 38 shopfronts were exemplary or positive of which 3 Exemplar Heritage shopfronts have no protection from removal, see pages 140-141.

The lack of protection for many heritage shops causes heritage harm during shopfront renewals. Valuable heritage Console Brackets & Cornices can more easily be ignored and damaged if not on a protected list, see pages 118-119. The following non protected shops have or had Console Brackets & Cornices which need specific protection, Essex Road 66, 68, 97, 99, 101, 105, 107, 110, 111, Cross Street 42, 44, 46, 47, 48, 50, 52, 54, 56, 58, 60, 65, 67, 69, Shillingford Road 8, 6, 4.

Although in the current guidance 26 properties protected, only 23 are shops within CA13. Inaccuracies in the current shop protection guidance are: a pub, a non-shop, and a shop outside of the Conservation Area. Also harmed shops are protected while some exemplar shops are not, 107 Essex road below.

Inaccuracies in current guidance



96 Essex Road



83 Essex Road



left 107, right 109 Essex Road

Cross Street (CA13) Conservation Area Design Guidelines

January 2002

The Council wishes to retain all locally and statutorily listed buildings together with all the 18th and 19th century buildings and structures in the area and the shopfronts listed below. Conservation area consent will only be granted for their removal where there are special circumstances or where the proposal would preserve or enhance the character or appearance of the conservation area.

Cross Street: 2, 4, 34, 36, 38, 40, 62, 41, 49, 51, 63, 71

Dagmar Passage: 14

Essex Road: 59, 65, 67-69, 83, 93-95, 109; 70, 84 (The Half Moon PH), 88, 96, 112

Shillingford Street: 2



AUDIT CURRENT Harm is still happening



8 Shillingford before May 2022

The council is still allowing single glazing despite declaring a climate emergency in June 2019.

One example granted recently of 8 Dagmar Terrace within CA13. It was a complete removal and rebuilding. The council allowed it to match adjacent harmed shops. The cornice and console brackets were not reinstated nor were doors and large glass areas double glazed.



4/2 Shillingford St, missing Console Bracket



8, 6, 4 and 2 Shillingford St, Heritage damage allowed no Console Brackets or Cornice.

Currently the Urban Design Guide is violated

The design of 8 Shillingford is contrary to the Urban Design Guide, which states

5.203 **New shopfronts to historic buildings should follow the principles of traditional shopfront design. They should be well proportioned and comprise of pilasters, corbel brackets, cornice, fascia, clerestory, a shop window divided with mullions and a stall riser. Signage should comprise of hand painted letters to a timber fascia or individually applied letters and a single modestly sized projecting or hanging sign illuminated by discrete individual light fittings.**

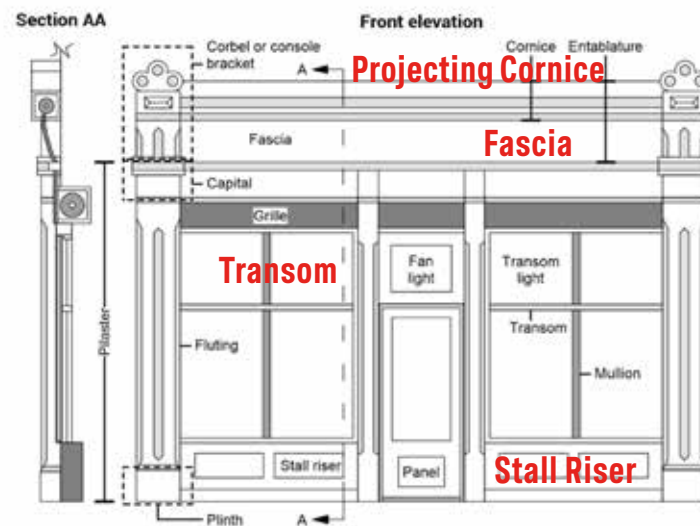
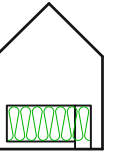

Figure 30 Basic elements of a traditional shopfront design

Islington Urban Design Guide 2017 SPD, Supplementary Planning Guidance, Page 67

SPD PRINCIPLES

Cornice and Console Brackets



All of the shops in the CA are heritage and would have had Console Brackets but many have been lost. The surviving brackets give a good indication of how to replace the missing ones. A shop parade built at the same time will have single brackets between shops, Abutting buildings have two side by side.

Most of the Console Brackets in this neighbourhood are composed of three parts; top half circle which sits above the cornice and flashed into it, square flat section which aligns with the top and bottom of the cornice (71 below), and the curved console itself which aligns with the recessed flat signage fascia. The bottom of the projecting Cornice creates a strong shadow line to the stepped back signage fascia. This shadow and the 3 dimensionality of these elements frame the shopfront and give the building a base distinct from upper parts. Modern flattened large fascias do not provide sign rain protection.



Two Colour Painting of Brackets invisible, denies heritage detail

Propose ban of 2 colour split painting, paint a neutral colour between shops



38 Cross Street, left Console Bracket missing



70 Essex Rd, bad gaps



93 Essex Road, cornice missing



112/110 Essex Road unique Art Deco brackets



47 Cross Street, Fascia too large, Cornice not aligned with Bracket, bad detail top gaps.



47 / 49 Cross St, Cornice too high bad gap details, should be lower align to bracket.



71 Cross Street, **CORRECT CORNICE** alignment Stepped Fascia

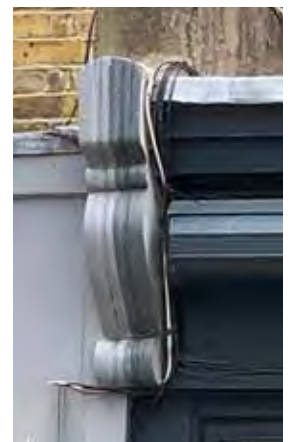

42 / 40 Cross St

A!

AUDIT Current Fascia Harm

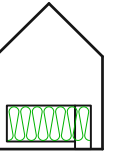

Positive /Negative Audits would pick up these problems of where fascias have been harmed. This more detailed approach Conservation Area Appraisal would show where heritage harm has occurred and give clear direction for future repairs. Current guidance does not protect these shops which leads to more heritage harm.

A) OVERSIZE FASCIA PANELS - No projecting Cornice

Fascia to be rebuilt with stepped cornice and smaller fascia aligning to pilaster



Water Damage 56 Cross Street, without Traditional detailing of flashed projecting cornice. Even expensive well maintained shops can't cope with bad detailing. Shop needs frequent repair and repainting. This shop has had three water damage repair and repainting in the last few years. It needs traditional top flashing extended with drip over front and signage recessed away from any water. See Heritage Correct

B) DIAGONAL FASCIA PANELS - Hiding original Cornice, Fascia, & Bracket

ALL diagonal new panels must be removed to show stepped cornice/fascia



65/67 Cross Street, Signage Fascia large, obstructs bracket

58/56 Cross Street, Signage Fascia large, obstructs bracket

63/65 Cross Street

C) SIGN PANELS- Sign board competes with architectural elements

Remove sign and paint logo



49 Cross St, Heritage Correct



49 Cross St, Sign detracts from Heritage

Islington Urban design Guide 2017 Supplementary Planning Guidance states

5.203 'New shopfronts to historic buildings ...Signage should comprise of hand painted letters to a timber fascia or individually applied letters'

D) POOR EXTENSIONS- not respecting neighbour, poor junctions

Built too close to neighbour. Need to be rebuilt set in from party wall junction.



72 Essex Road, shop extension built tight on centre of party wall (or even over the line) not to inside as normal with shops. Roller shutter box extends in front of neighbours window!!



A!

SPD TECHNICAL CASE STUDY

Former Islington Council Offices Upper Street

This is a good precedent for shopfront retrofit the former Islington Council Offices, 159-167 Upper Street. These council offices with modern façades were returned to Heritage with 9 double glazed shop units within the Upper Street Conservation Area which is adjacent to CA-13. They were reinstated March 2011 - Nov 2012 with Corbels, Pink Granite Pilasters, Fascia Cornices, Stall Risers, Timber doors and Window frames and DOUBLE GLAZED shop window.

Unfortunately this precedent from 10 years ago has not been repeated for other current shop refits which are still using single glazing.

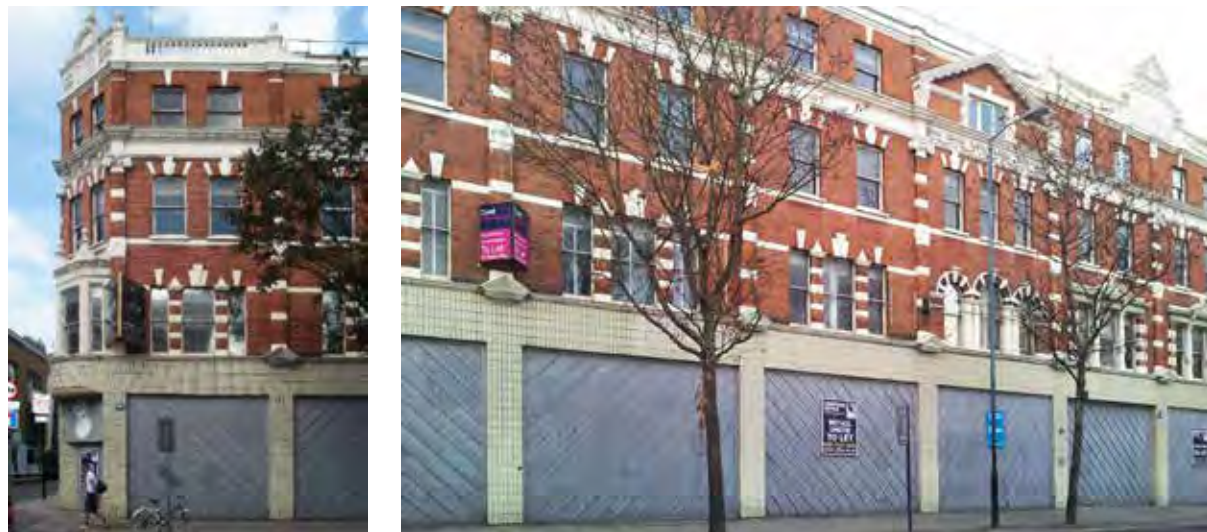

Pre 2012 159, 160, 161, 162, 163, 164 Upper Street after Islington Council vacated building, glass window frontage boarded up, missing- Brackets, Pilasters and heritage details

A good detail reinstatement, with double glazing



May 2022, 159, 160, 161 Upper Street **double glazed shopfronts with heritage details rebuilt**



May 2022 166, 167 Upper Street **double glazed shopfronts**

Double Glazed Shopfront Details

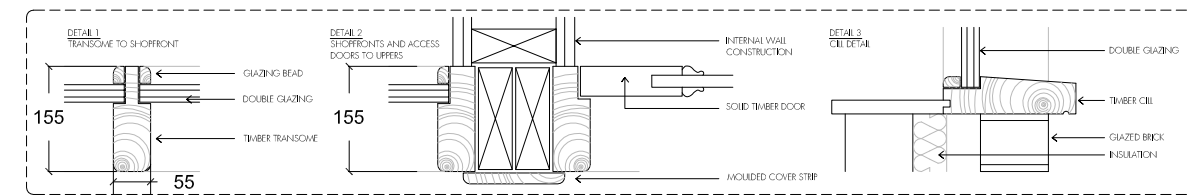
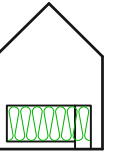

2012 159-167 Upper Street **typical new double glazed details**



**Restored Heritage Facade - power of repetitive elements
Pilasters and Brackets between shops.**

Design by Tasou Associates Architects + Structural Engineers

SHOPFRONT SUMMARY

2002 guidance continues heritage harm

Victorian shopfronts have often been severely harmed. For instance, in CA13 (established in 1970) still only 11 out of 60 are unharmed which shows a failure to protect heritage.

Traditional shopfronts with overhanging cornices and set back fascia protect rain damage to the signage area. They also give a strong shadow line and completion of the shop zone to the accommodation above. Replacement large sign panels obscure all traditional details as well as hide damage allowing water penetration between old and new.

These larger signs squeezed out the console bracket as they protrude beyond. With the bracket partly hidden, missing or damaged brackets are less noticeable and often their repair ignored to the extent that some

councils do not insist on replacement of missing console brackets.

Much damage also occurred due to security roller shutters installed on top of facade blanking out street details. For instance, in CA13 although they are gradually being replaced by new internal conservation approved there are still 15 out of 60 shops with these.

Some councils are continuing to approve single glazed shop refits in Conservation Areas; in CA13, for example, one was approved in 2021 and 58 out of 60 shops are still single glazed. A few meters away on 159-167 Upper Street the council's ex-offices were restored to a double glazed parade of shops, approved in 2012. The model in CA13 is local and the techniques are known.

high % of heat loss, shop windows are easier to retrofit than other elements.

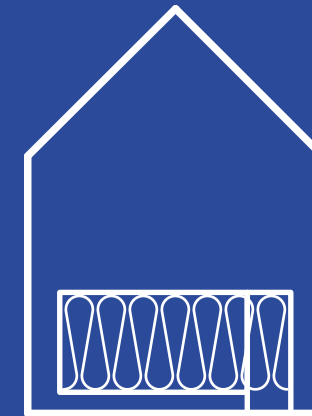

RECOMMENDATIONS for new Local Development Consent Order, SPD, and/or CA Guidance

1. Require that changes to shopfronts provide double or triple glazing and doors to meet 2021 Building Regulations requirement of 1.6W/m²K.
2. Require that new shopfront signage reinstate Console Brackets and projecting Cornices.
3. **Fire escape door**
Require that there be appropriate facade doors for flats above shops, so that there is direct fire escape not through shops, image left.
4. Make a clear list of 'Unharmed', 'Positive with some harm' and 'Negative' shops in revised CA Appraisal document.
See Islington CA13 example on page 160.
5. Ensure that local business support and partnerships (such as the Energising Small Business Fund and the Islington Sustainability Network in Islington) act to motivate the double glazing of shops.

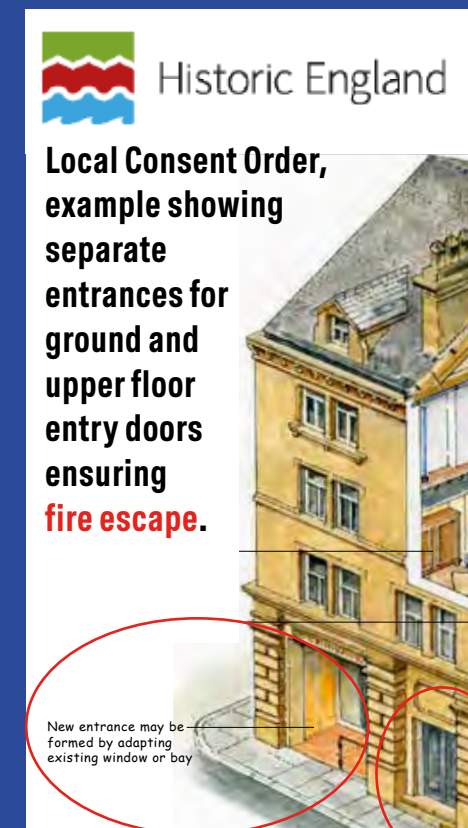

Drawing up a Local Listed Building Consent Order, Historic England Advice Note 6

3.0 APPENDICES

3.1 TOOLKIT -Step 2 continued

BUILDING AUDITS

With Photographic Survey of

**NEGATIVE,
NEUTRAL,
POSITIVE, &
LISTED BUILDINGS**

SHOPFRONT AUDITS

With Photographic Survey of

**NEGATIVE,
DAMAGED POSITIVE, &
EXEMPLARY SHOPFRONTS**

3.1.1 NEGATIVE BUILDING AUDIT

LB of Islington CA13

Buildings in a CA with a **detrimental effect on area heritage features.**
Suitable for extensive energy retrofitting with a view to improve the facade or extend the building massing to enhance the heritage area.
 Preference for redevelopment rather than demolition.

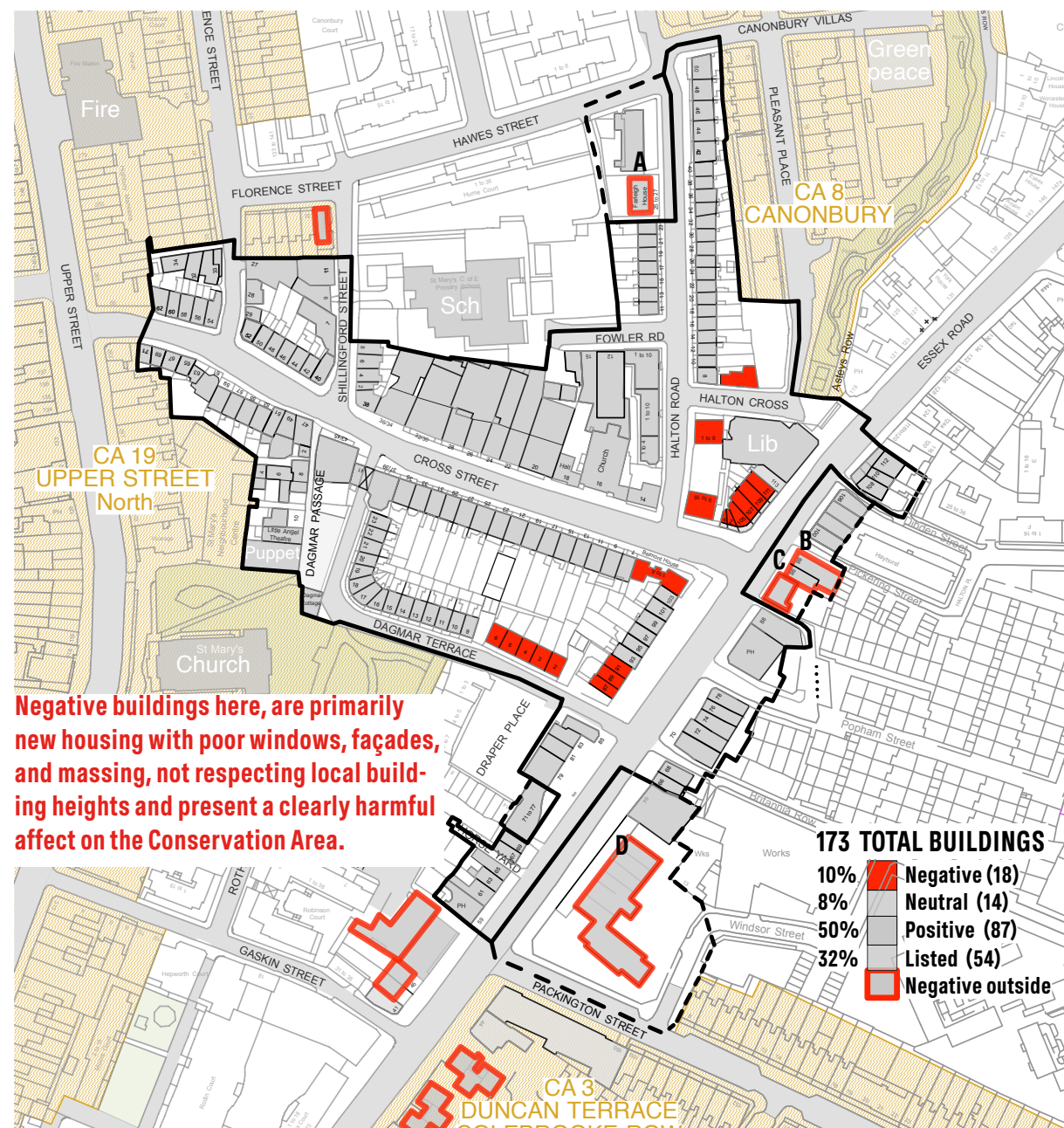

Negative buildings here, are primarily new housing with poor windows, façades, and massing, not respecting local building heights and present a clearly harmful affect on the Conservation Area.

Negative Building Map - ACAN worked example London Borough of Islington CA13

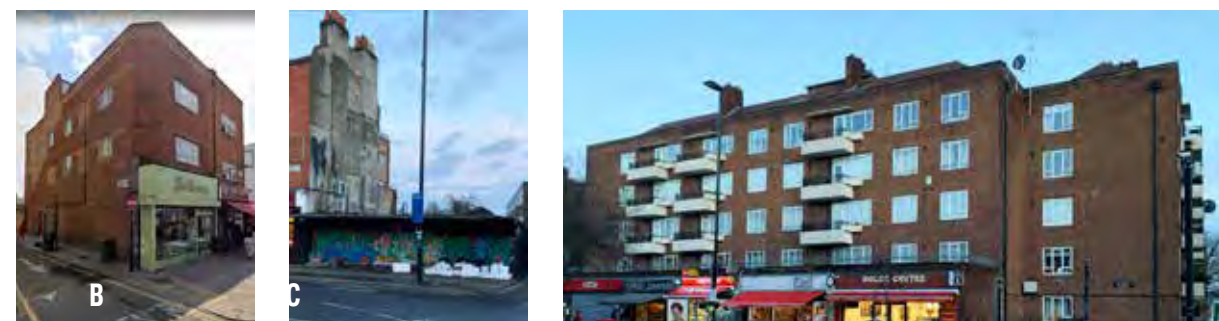

130 Negative buildings across Essex Road within visual realm impacting the CA.

photographic survey of all Negative Buildings with problems and recommendations

(10%) **18**
negative buildings



1-8 Fircroft House, Halton Rd
 Poor finishes, PVC windows, and out of scale, suitable for external insulation, new windows, and balcony/ facade extension.



9-16 Fircroft House, Halton Road
 Poor finishes, PVC windows, and out of scale, suitable for external insulation, new windows, and balcony/ facade extension.



Halton Cross workshop/garage



2, 3, 4, 5, 6 Dagmar Terrace /rear garages
 Lost heritage 4 storey terrace infill with out of scale 2 storey modern terrace damaging the Conservation Area. Poor windows and details suitable for external insulation, new windows, and additional storeys.



1-8 Belmont House, Cross Street
 Poor windows, details, and facade composition out of alignment with Heritage Terrace. Suitable for external insulation, new windows, and facade details.



87, 89, 91 Essex Road
 Out of scale, poor windows and facade, floor heights not matching original terrace. Suitable for external insulation, new windows, and an additional storey.



Essex Road parade of shops see pg 38



Negative building across Halton Road

3.1.2 NEUTRAL BUILDING AUDIT

LB of Islington CA13

Buildings in a CA with limited or no notable heritage features. Suitable for extensive energy retrofitting with a view to improve the facade or extend the building massing to enhance the heritage area. Preference for redevelopment rather than demolition.

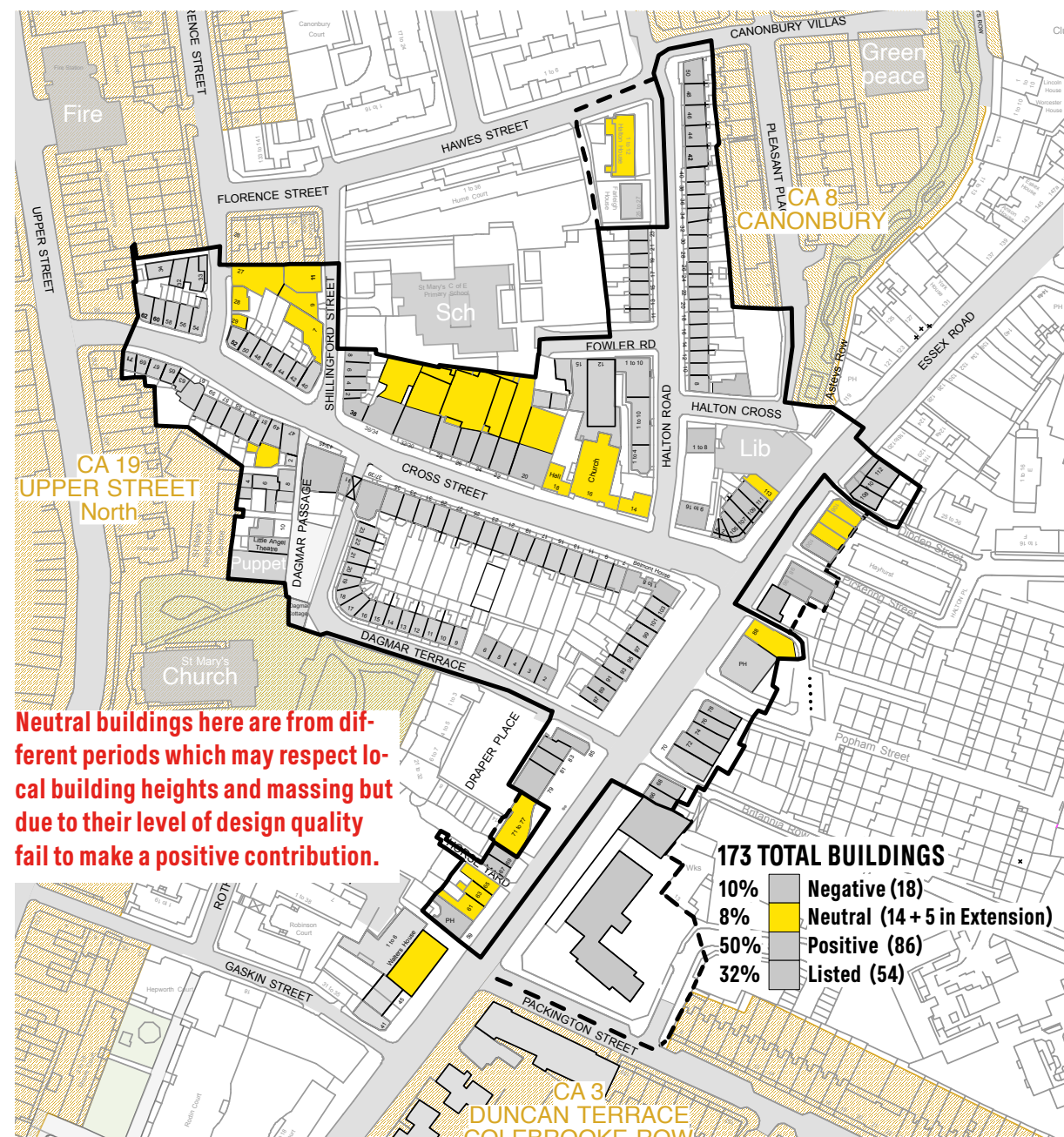

Neutral buildings here are from different periods which may respect local building heights and massing but due to their level of design quality fail to make a positive contribution.

Neutral Building Map - ACAN worked example London Borough of Islington CA13



Cross Street Warehouse backs suitable for triple/quad roof lights and high levels of roof insulation



29 Florence St -Closet Ext. Out of scale Suitable for ext insulation.

photographic survey of all Neutral Buildings with problems and recommendations

(8%) **14+**
neutral buildings



88 Essex Road
Modern rebuild lacking historic details suitable for external insulation.



113 Essex Road
Modern interpretation lacking historic details suitable for external insulation.



7, 9, 11 Shillingford Street Houses
"Developer Modern" suitable for external insulation.



28 Florence Street
Modern developer interpretation not matching local heritage typology.



61 Essex Road
Modern rebuild lacking historic details suitable for external insulation and new windows.



63, 65 Essex Road
Poor windows and building massing at roof level suitable for external insulation and new windows



27 Florence Street
"Developer Modern" suitable for external insulation.



16, 18 Cross Street
Modern church out of scale suitable for creative extensions.



14 Cross Street
Low cottage out of scale with terraces suitable for creative extensions.

3.1.3 POSITIVE BUILDING AUDIT

LB of Islington CA13

Buildings in a CA with positive heritage features which precludes significant change to front façades unless there is heritage harm caused by unsympathetic alterations. Where damage has occurred best LETI practice retrofit is encouraged. Timber double glazed replacement windows or triple glazed are suitable on all façades. Rear and private realm façades are suitable for more extensive retrofit.

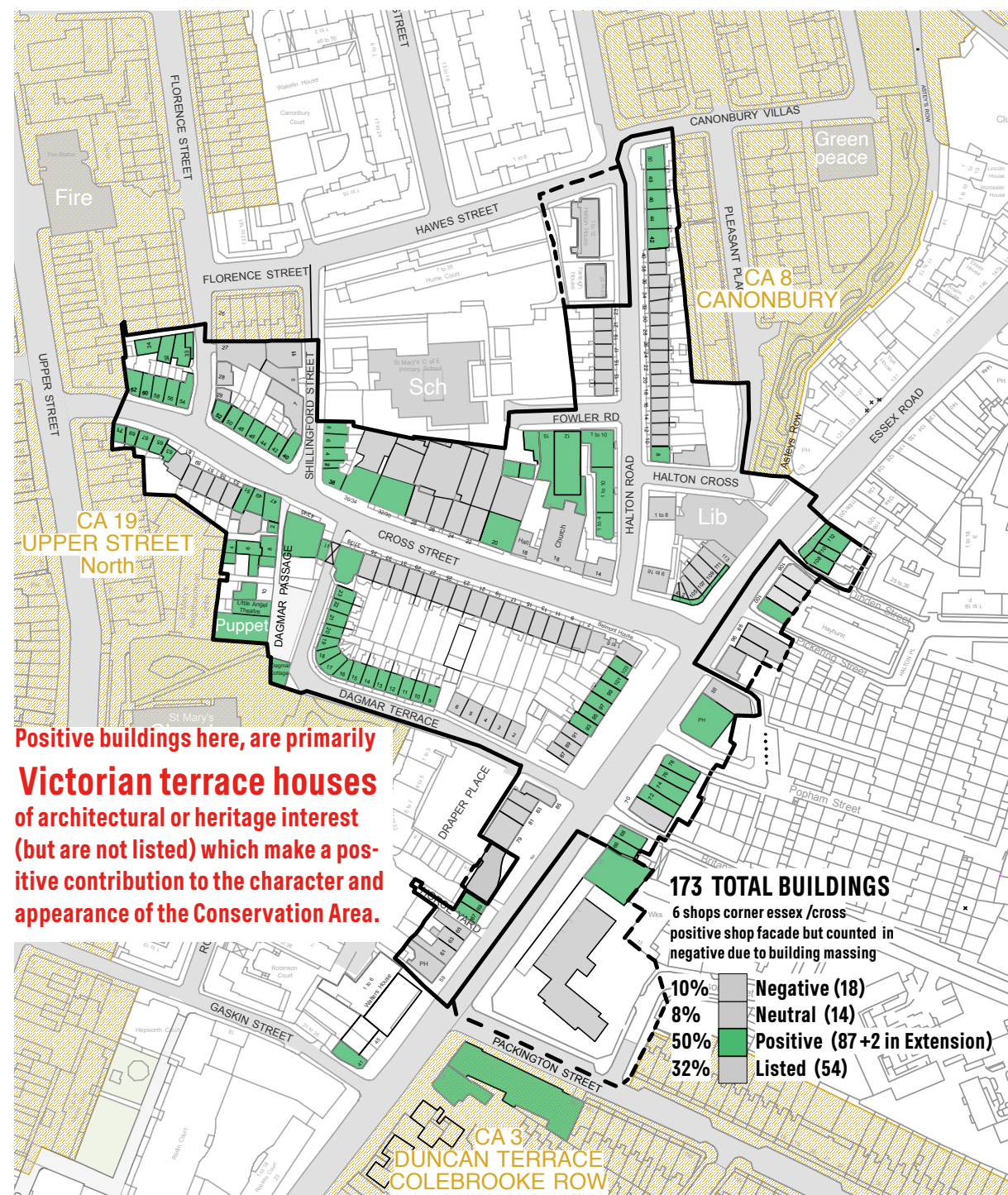

Positive buildings here, are primarily Victorian terrace houses of architectural or heritage interest (but are not listed) which make a positive contribution to the character and appearance of the Conservation Area.

Positive Building Map - ACAN worked example London Borough of Islington CA13

photographic survey typical of the 87 Positive Buildings with problems and recommendations

✗ Heritage damaging non original windows on Victorian buildings



23, 21, 20, and 19 Dagmar Terrace non period windows suit replacement



6 shop parade Cross & Essex. Shop fascia and windows damaged, Positive heritage fascia to retain.

Single story is damaging to the Conservation Area scale. Redevelop both sites with 3 additional story residential best new practice.



90-92 Essex Road



112, 110, 108 Essex Road Shopfronts harmed, new windows mismatched with reduced size. Suitable for external insulation & windows.



72 Essex Road Shopfront & windows harmed, suitable for Mansard fill in

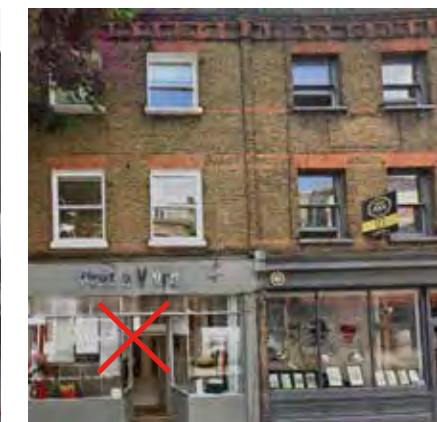

69, 71 Cross Street Shopfront harmed, suitable for Mansard fill in



52, 50, 48, 46, 44, 42 Cross Street, Mismatched windows suitable for double glazed replacements

(50%) **87**
positive buildings

3.1.4 LISTED BUILDING AUDIT

LB of Islington CA13

Buildings in a CA with positive heritage features which precludes significant change to front façades unless there is heritage harm caused by unsympathetic alterations. Where damage has occurred best LETI practice retrofit is encouraged. Timber double glazed replacement windows are suitable for damaged windows. Rear and private realm façades are suitable for more extensive retrofit.

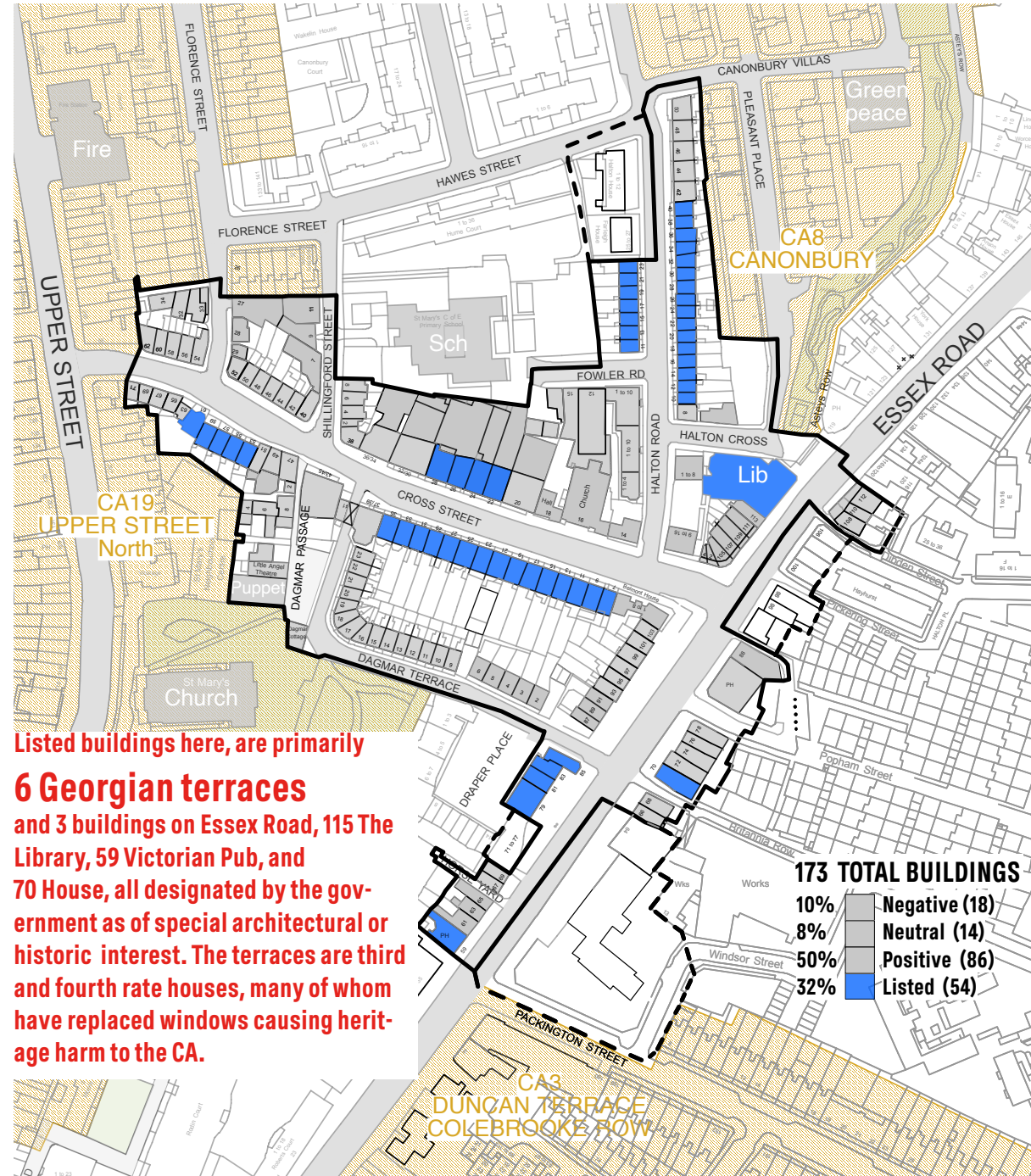

Listed buildings here, are primarily **6 Georgian terraces** and **3 buildings on Essex Road, 115 The Library, 59 Victorian Pub, and 70 House**, all designated by the government as of special architectural or historic interest. The terraces are third and fourth rate houses, many of whom have replaced windows causing heritage harm to the CA.

Listed Building Map - ACAN worked example London Borough of Islington CA13
 Official List all Buildings, <https://historicengland.org.uk/listing/>

photographic survey of typical Listed Buildings with problems and recommendations

✗ Heritage damaging non original windows on Georgian buildings

(32%) 54
listed buildings



40, 38, 36 34 Halton Road



13, 15 Halton Road



12 Halton Rd



18 Halton Rd



28, 26, 24 22 Cross Street



70 Essex Rd



23-29 Cross Street, loss of door pediments on 23,27, & 29 Cross Street



15, 17, 19 Cross Street



53, 55, 57, 59 Cross Street

3.2 SHOPFRONT AUDIT

60 shopfronts

A few English councils have carried out Building Audits, as shown in section 1.4.2. This system promoted by Historic England allows a more tailored approach to heritage amenity within CAs but also allows public environmental amenity to be assessed. In this example we have assessed Negative, Positive, & Exemplary, with accepted practice colours used in the colour coding.

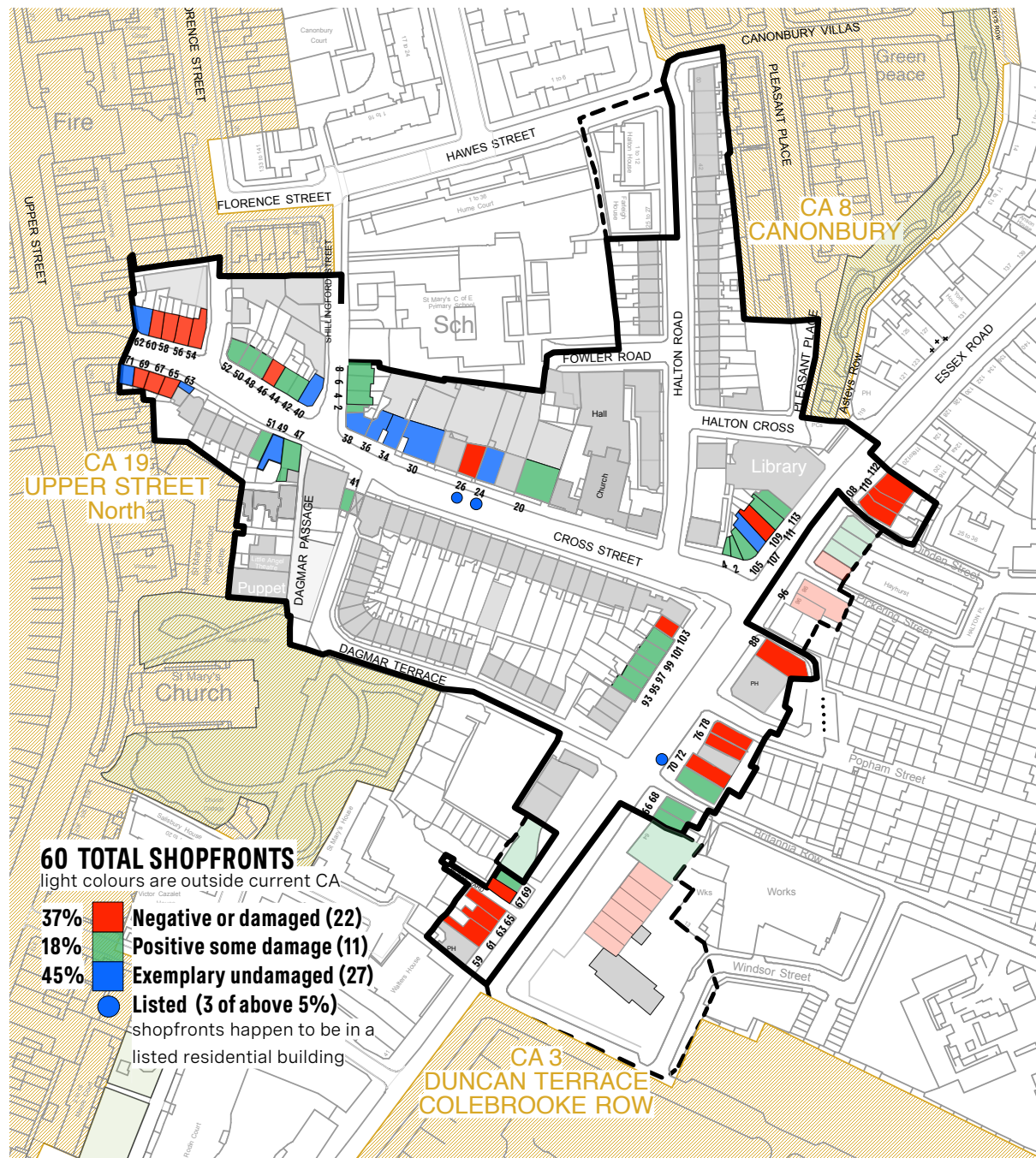

Shopfront Positive/Neg Audit Map - ACAN worked example London Borough of Islington CA13

Positive/Negative

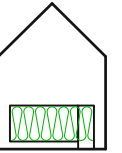

The same Historic England system used for buildings with Negative, Neutral, Positive and Heritage can also be used for shopfronts. This gives a more nuanced detail understanding rather than only list those for protection as is current practice in CA13.

Most of the 56 shopfronts and 4 Workshops are old heritage. Positive shopfronts have main window door layout but missing details such as brackets and cornices. Negative shopfronts had either; window door changes, details damaged/hidden behind large signs, or many (11) having external roller shutters damaging the street at night. Exemplar shopfronts were mainly intact or reconstructed heritage. Neutral did not apply as there are no contemporary shopfronts.

EXEMPLAR unharmed Heritage,
POSITIVE some harm, and
NEGATIVE severe harm.

Detailed assessment allows better heritage protection with climate protection retrofitting. All of the shopfronts are suitable for double glazing, bringing to 100% double glazed (60).

11 Unharmed Exemplar Shopfronts
see following pages 116-117

27 Positive some harm
see Appendices pages 152-153

22 Negative Shopfronts
see Appendices pages 154-155

3.2.1 EXEMPLAR Heritage Shopfronts (9 of 60)

photographic survey of ALL good Heritage Shopfronts

9

5 MUST HAVES

1 Signage Lettering

- On painted fascia background, no sign panel.

2 Fascia (signage) w Projecting Cornice

- Provides Shadow line and water protection.

3 Console Brackets

- Frames Cornice & breaks between shops.

4 Stall Riser

- Windows should not start at floor.

5 Large Transom above door

-Should align with top of high shop windows.



40 Cross St, Heritage Correct



62 Cross St, Heritage Correct



36 Cross St, Fascia covers recessed grill- see 34 Cross St



34 Cross St, Heritage Correct



63 Cross St, House,return Shop, replace grills for a better street



71 Cross St, Heritage Correct



49 Cross St, Heritage Correct



38 Cross St, Heritage correct ready for double glazed windows.



107 Essex Rd, a Unique Parade Pilasters & Brackets should be painted single colour, not split.

EXEMPLAR heritage WORKSHOPS (2 of 60)

no protection in current guidance

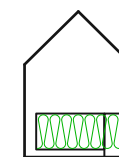

2



26 Cross St, Harmed Roller Shutter basement

30 & 24 Cross Street are fine examples of ground and basement warehouse workshops with no. 30 recently double glazed in original sash. They are facade recessed for goods delivery and 24 still has the original crane. It appears windows may have been replaced at the entrance of 30 as there is an angled wall in the recess. Painting this to match the red windows would blend it with the original.

The quality of these façades is contrasted with harm at No 26. It has a basement external roller blind box hiding the floor beam on which new secondary glazing has been built above. Original solid low panelling have windows cut into them and main windows replaced above secondary glazing.



30 Cross St, Changes in X area. Paint red to match windows



24 Cross St, Heritage Correct



30 Cross St, Recessed Basement window wall. Heritage correct. Double glazed units in old mullions.



24 Cross St, Basement recess



A!

3.2.2 POSITIVE Damaged Shopfronts

photographic survey of ALL POSITIVE damaged Shopfronts

27 of 60
Positive
Damaged

**MISSING
Cornices and Brackets**



93 Essex Rd, Cornice missing 95 Essex Rd, Bracket missing



8 Shillingford Rd, Cornice and Brackets missing



6 Shillingford Rd, Cornice and Brackets missing



4 Shillingford Rd, Cornice and Brackets missing



2 Shillingford Rd, Cornice and Brackets missing



46, 44, & 42 Cross Street, Cornice and Brackets missing, Fascia Signage too large drops lower than bracket 40, Transom 42



47 Cross Street, Fascia sign not separate letters, bad flashing with Cornice missing



20 Cross Street, new Windows paint dark colour see 30 & 24.



51 Cross Street, Now a House, Cornice and Brackets missing door window to match



97 Essex Rd, Cornice and Brackets missing



99 Essex Rd, Brackets missing



101 Essex Rd, Cornice and Brackets missing



52 Cross Street, Cornice and Brackets missing, mirror other end 40 Cross



50 Cross Street, Cornice and Brackets missing, low fascia



70 Essex Rd, Cornice missing



4 & 2 Cross Street, Brackets missing



105 Essex Rd, no Bracket, sign panel remove



111 Essex Rd, Brackets missing external shutter, door location



41 Cross Street, Cornice and Brackets missing

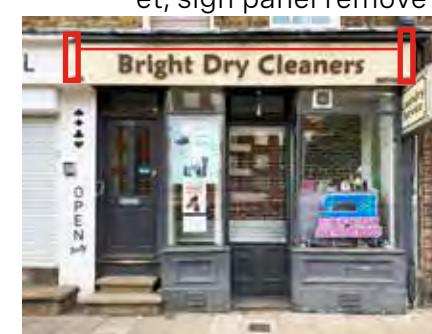

69 Essex Road, Cornice and Brackets missing



113 Essex Road, Cornice and Brackets missing



68 & 66 Essex Road, Cornice and Brackets missing



**MISSING
Cornices and Brackets**

A!

3.2.3 NEGATIVE Harmed Shopfronts

photographic survey of ALL NEGATIVE damaged Shopfronts

22 of 60
Negative



96 Essex Rd, Shop outside CA



112 & 110 Essex Road, Signage out of scale, Roller shutters



60 Cross St, Signage oversize Aluminium needs rebuild



58 Cross St, Fascia Oversize missing Cornice and Brackets



54 Cross St, Fascia Oversize missing Cornice and Brackets



65 Cross St, Fascia Oversize, Windows and door rebuild



67 Cross St, Fascia Oversize Windows and door rebuild



69 Cross St, Fascia Oversize Windows and door rebuild



65 Essex Road, solid panel in window area, low stall riser



46 Cross St, cornice, brackets Aluminium, needs rebuild



26 Cross St, Roller Shutter, windows damaged

Major problems- 12 Shops with Roller Shutters, Signage out of scale, Stall Risers, Transoms, Cornices and Brackets.

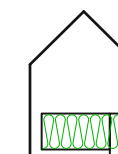

56 Cross Street, Damaged Console Bracket, No Cornice, Signage Fascia too large, Out of Scale.



109 Essex Road, Protected



61 Essex Road, roller shutter sign obstructs cornice fascia



63 Essex Road, roller shutter sign obstructs cornice fascia



76 Essex Road, sign obstructs cornice and fascia



108 Essex Road, missing cornice and right bracket



67 Essex Road, roller shutter sign obstructs cornice fascia



72 Essex Road, roller shutters sign obstructs cornice fascia



88 Essex Road, roller shutter no stall riser, brackets, cornice.

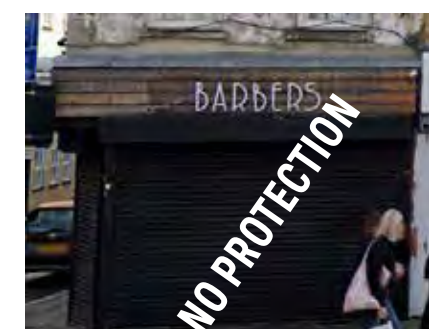

78 Essex Road, roller shutter, sign obstructs cornice fascia



103 Essex Road, return into Flat



WINDOW AUDITS

with Photographic Surveys

for replacement of

**Classical Georgian,
Distinctive Victorian,
Functional Victorian,&
Modern Windows**

GEORGIAN WINDOWS (listed) Front Audit



Correct timber slim-profile double glazed slim -profile, Halton Road



37 Listed houses with incorrect period windows compromise the character and appearance of the Conservation Area. The original 6 over 6 divided pane windows have been unevenly replaced with different later window types leaving the terrace mismatched, non uniform, and messy. As these are no longer original, there is both a heritage and environmental benefit to replace single windows with 6 over 6 timber slim profile/cavity or evacuated glass. Cross Street -15,17,19,22,23,24,25,26,27,28,29,53,55,57,59. 13,21,31,33,35,61. Essex Road -70, 85. Halton Road -13,15,12,18,34,36,38. 17,19,21,23,24,26,40. Remaining 13 Listed buildings may have original windows, therefore they need to be reviewed on a case by case basis. New timber double glazed are on 14 & 16 Halton Rd.

Left image Harmed single glazed replacement, Arch window Halton Rd. Wrong glazing bars, Infill wood at top as unit not fitted to brick arch. Needs new double glazed unit correctly designed.

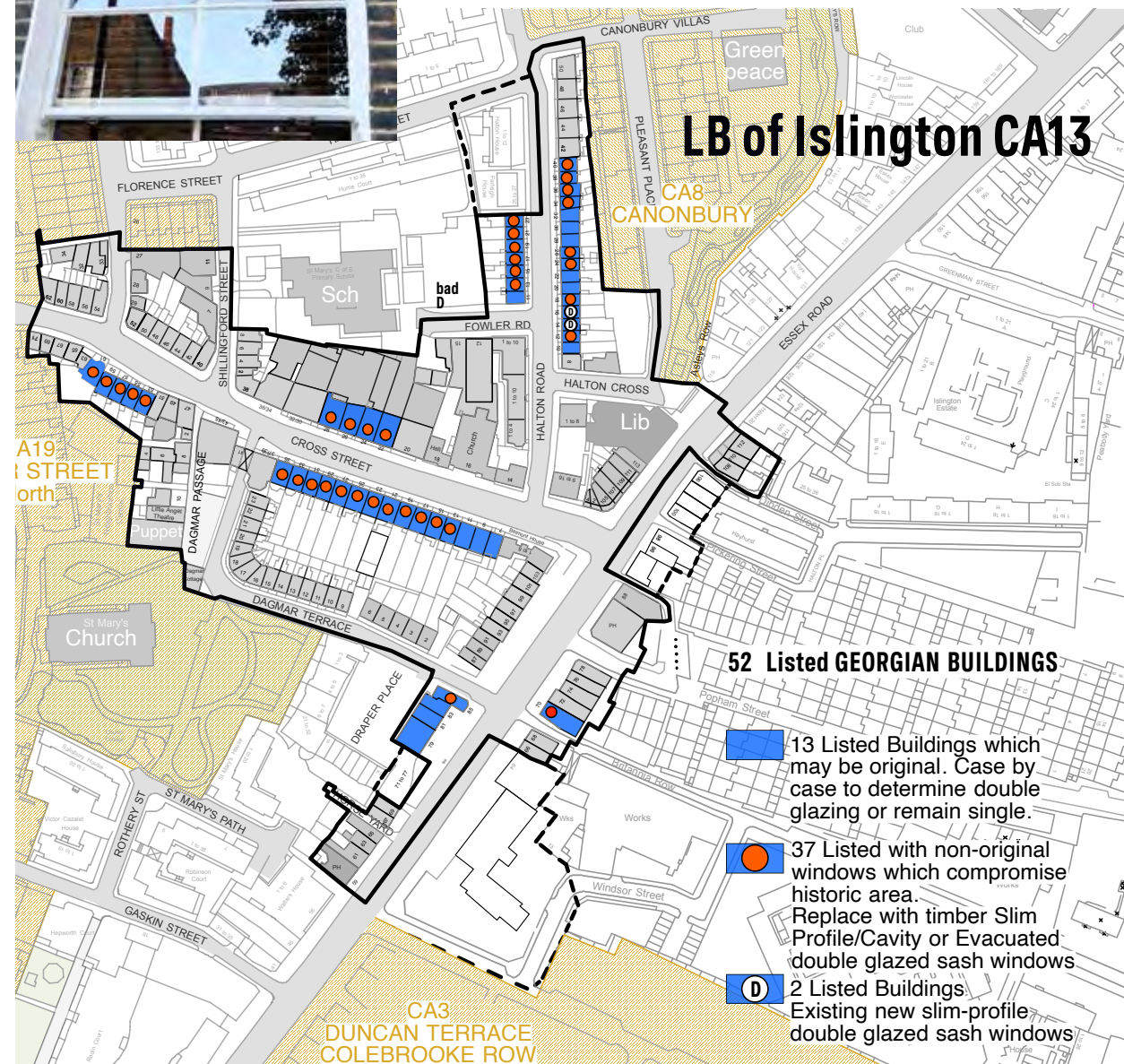

GEORGIAN WINDOWS (listed) photographic survey of façades

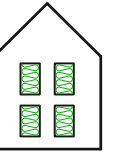

✗ Heritage harm. Non-original windows on Georgian buildings



38, 36 34 Halton Road



13, 15 Halton Road

37 of **52** suit new timber slim or evacuated glass double glazed



12 Halton Rd



18 Halton Rd



28, 26, 24 22 Cross Street



70 Essex Rd



23, 25 Cross Street



27, 29 Cross Street



15, 17, 19 Cross Street



53, 55, 57, 59 Cross Street, 6 over 6 replaced with 2 over 2 Victorian with modern replica wavy glass

Distinctive VICTORIAN WINDOWS Front Audit



typical 9-23 Dagmar Terrace

14 Distinctive Victorian buildings on two terraces on Cross Street and Dagmar Terrace have damaged/incorrect divided sash which are suitable for new timber slim cavity or evacuated glass double glazed windows. 8 Halton Road is a non-listed reproduction Georgian suitable as are houses on Essex Road. Council policy is to allow replacement on non listed, (14 Dagmar Terrace approval in 23 June 2021).

DAGMAR TERRACE -23,22,21,20,19,18,17,16,15,13,12,11,10 & 9.
CROSS STREET -52,50,48,46,44,42,41, & 40.
HALTON ROAD -8. ESSEX ROAD -67,69,74,78

Several Victorian mansion buildings have intact sash which should be retained with new evacuated double glass panes inserted into this original sash on a case by case basis.

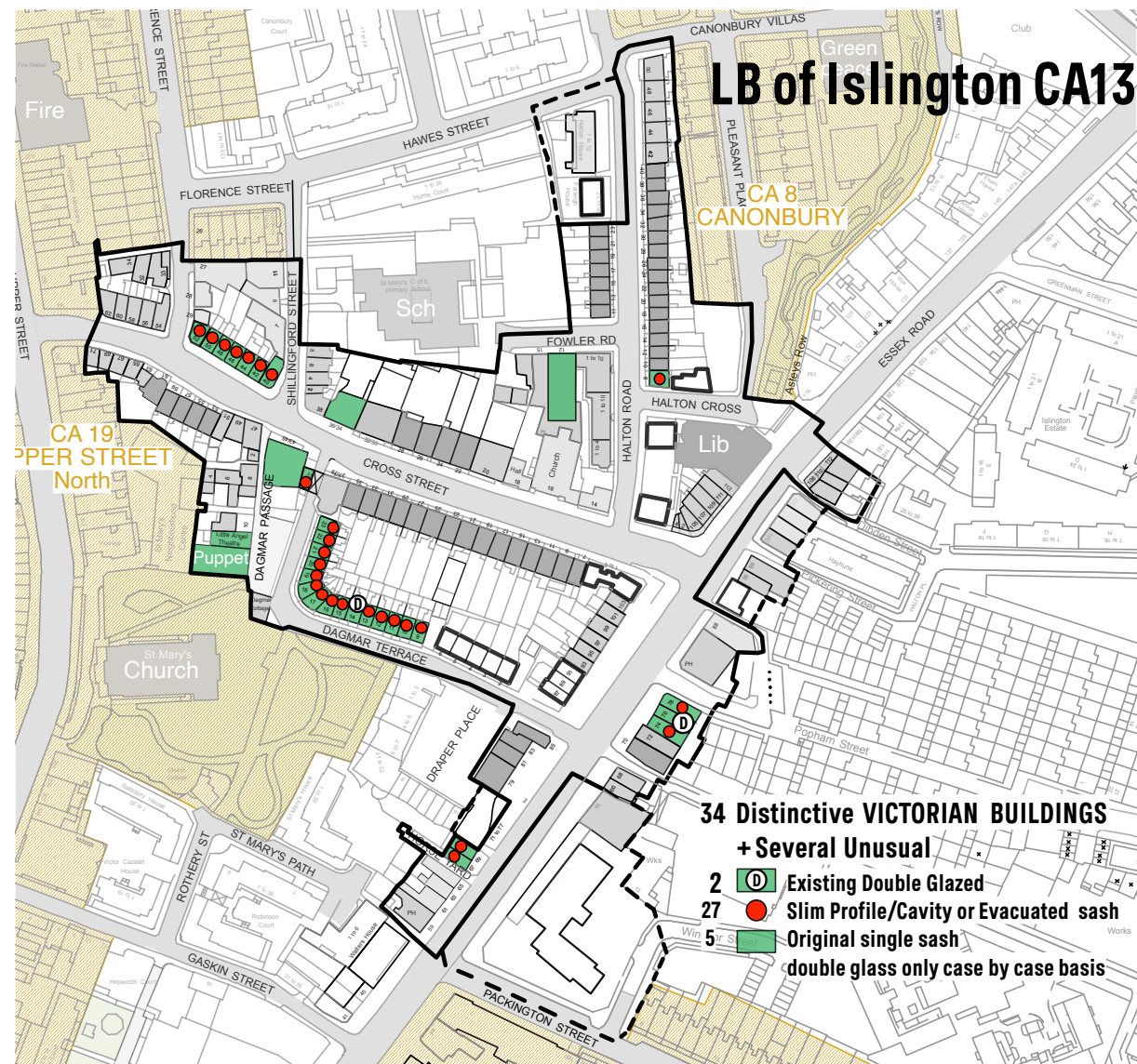

Victorian buildings window Audit - ACAN worked example London Borough of Islington CA13

Distinctive VICTORIAN WINDOWS photographic survey of façades

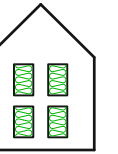

✗ Heritage harm. Non-original windows on Victorian buildings



12 Fowler Street secondary glazing



36/34 Cross Street heavy original sash suitable for evacuated double glass panes in the original sash.



36/34 Cross Street windows

27 of **34** suit new timber slim or evacuated glass double glazed



52, 50, 48, 46, 44, 42, 40 Cross Street, Mismatched new windows replace all with double glazed 44 and 42 are correct decorative Victorian type



23 21 20 19
23, 21, 20, and 19 Dagmar Terrace non period replace with double glazed



52 -40 Cross Street



18, 17, 16 Dagmar Terrace

13 Dagmar Terrace
fake Georgian

9 Dagmar Terrace 151

Functional VICTORIAN WINDOWS - Front Audit



These typically 1 over 1 larger glass panes of the functional Victorian window type lend themselves to low energy triple sash glazing, or the new timber conservation design simulated-sash triple glazed window. Any buildings with damaged, mismatched, or non original windows which compromise the character and appearance of the Conservation Area should be replaced, but as all of these buildings are not listed it is recommended all except the few with existing double glazing (4) be retrofitted from their existing draughty single to this triple glazed window type.

Triple glazed simulated hung sash designed for conservation areas

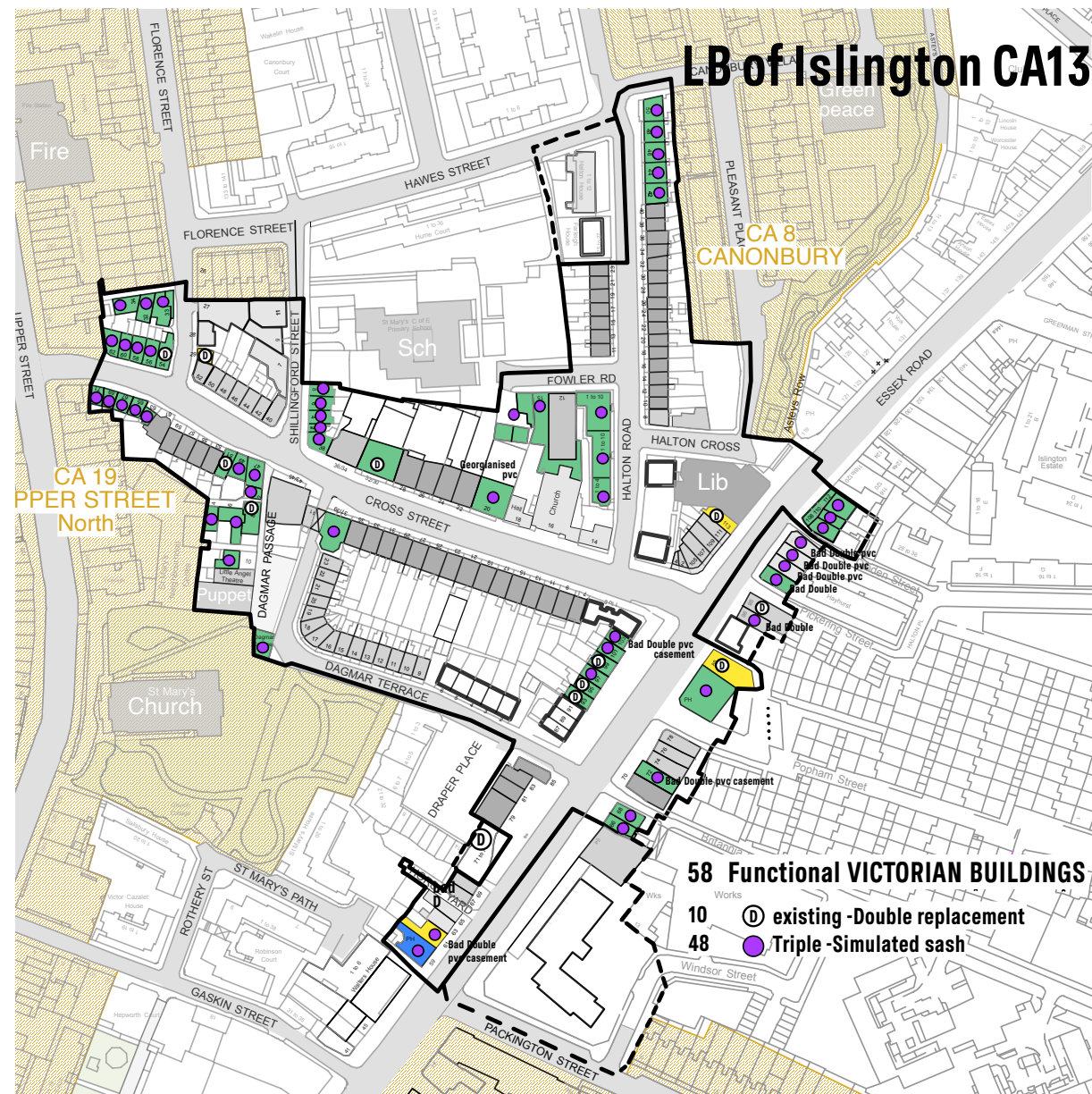

Victorian Triple window Audit - ACAN worked example London Borough of Islington CA13

Functional VICTORIAN WINDOWS photographic survey of façades

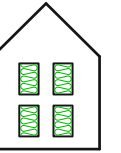

✗ Heritage harm. Non-original windows on Victorian buildings

48 of **58** suit new timber simulated-sash or regular sash triple glazed



63, 65, 67, 69, 71 Cross Street. Suitable for triple glazed 1 over 1.

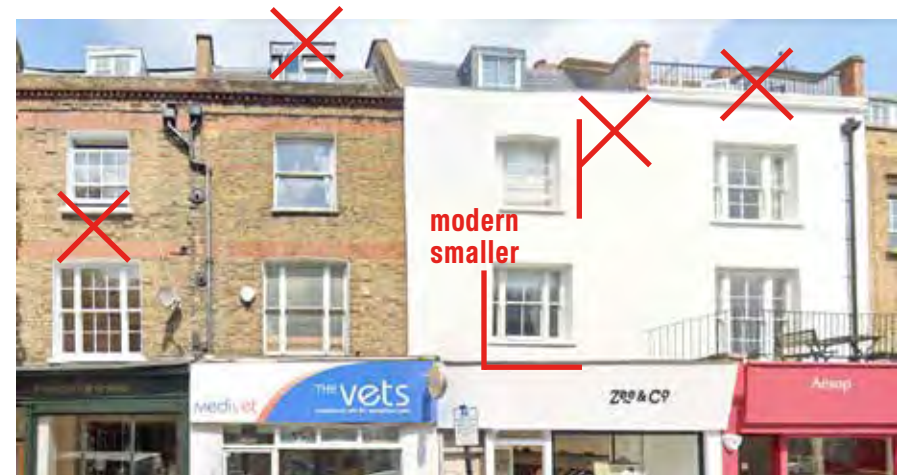

fake Georgian 62 (fake georgianised), 60, 58 (modern smaller), 56 Cross Street. All dormers wrong. Suitable 1 over 1 simulated sash triple glazed



fake Georgian 8, 6, 4, 2 Shillingford Street, 38 Cross Street. Victorian windows have been fake georgianised. All replaced with 1 over 1 triple glazed.



Functional VICTORIAN WINDOWS - photographic survey of façades

✗ Heritage harm. Non-original windows on Victorian buildings

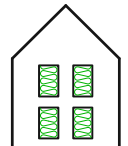

20 Cross Street, suit triple glazed



50, 48, 46, 44, 42 Halton Road, suit 2 over 2 triple glazed



37/39 Cross Street, suit triple glazed 2 over 2 panes



5, 7, 9 Halton Road, suit triple glazed 2 over 2 panes



Dagmar Cottage, suit 2 over 2 triple glazed



61 Essex Road, vinyl casement compromise heritage suit 1 over 1 sash triple glazed



59 Essex Road, suit triple glazed fixed & 1 over 1 sash



93, 95, 97, 99, 101, 103, Essex Road. Mismatched & Dormers compromised. Suit 2 over 2 triple glazed.



108, 110, 112 Essex Road suit 2 over 2 panes triple glazed.



15 Fowler Road, suit 2 over 2 sash triple glazed



88, 86 Essex Road, suit 1 over 1 sash triple glazed



78 Essex Road, Modern rebuilt Victorian, windows compromise heritage suit 2 over 2 sash triple glazed



72 Essex Road casement windows damage heritage, suit 2 over 2 sash triple glazed.



66, 68 Essex Road, suit 2 over 2 sash triple glazed



MODERN WINDOWS - Front Facade Audit



These post war buildings have very poorly detailed windows many replaced with heritage damaging thick vinyl double glazing out of scale, or even georgianised (65 Essex). Contemporary modern windows can now be triple glazed with thin frames matching the delicacy of traditional windows. Many of these buildings need more complete facade redesign.

63, 65 Essex Road

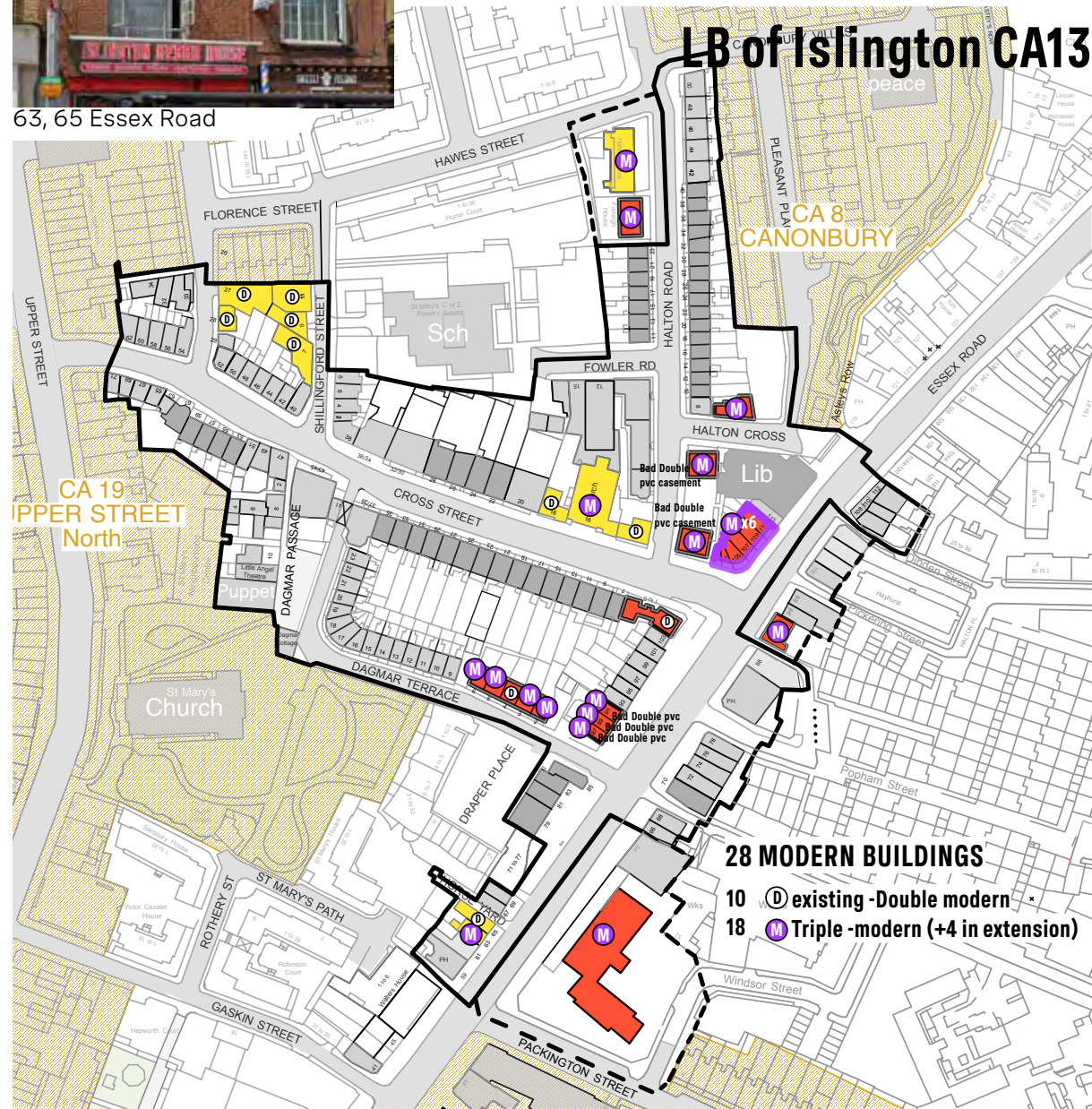

156 Negative buildings across Essex Road within visual realm impacting the CA.

MODERN WINDOWS photographic survey of façades

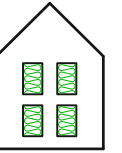

18 of **28**
suit new
modern
triple glazed



1-8 Fircroft House, Halton Rd
Poor finishes, PVC windows, and out of scale, suitable for external insulation, new windows, and balcony/ facade extension.



9-16 Fircroft House, Halton Road
Poor finishes, PVC windows, and out of scale, suitable for external insulation, new windows, and balcony/ facade extension.



Halton Cross workshop/garage



2, 3, 4, 5, 6 Dagmar Terrace /rear garages
Lost heritage 4 storey terrace infill with out of scale 2 storey modern terrace damaging the Conservation Area. Poor windows and details suitable for external insulation, new windows, and additional storeys.



1-8 Belmont House, Cross Street
Poor windows, details, and facade composition out of alignment with Heritage Terrace. Suitable for external insulation, and facade details.



87, 89, 91 Essex Road
Out of scale, poor windows and facade, floor heights not matching original terrace. Suitable for external insulation, new windows, and additional storey.



Essex Road parade of shops see pg 34



Negative building across Halton street 157

Islington CA13

PROPOSED Revisions GUIDANCE DOCUMENT

Quick textual changes shown in red of current 5 page CA Guidance Document on the following pages.

These are corrections and additions found from the Toolkit Audit data.

Mapping graphics and commentary from the toolkit could be added to the new Appraisal & Management Documents but in terms of expediency textual changes would more quickly update all 42 CAs in London Borough of Islington.

Existing Conservation Area Map LB of Islington CA13

Cross Street (CA13) Conservation Area Design Guidelines

Red text revisions

ACAN Revised from the current version of January 2002

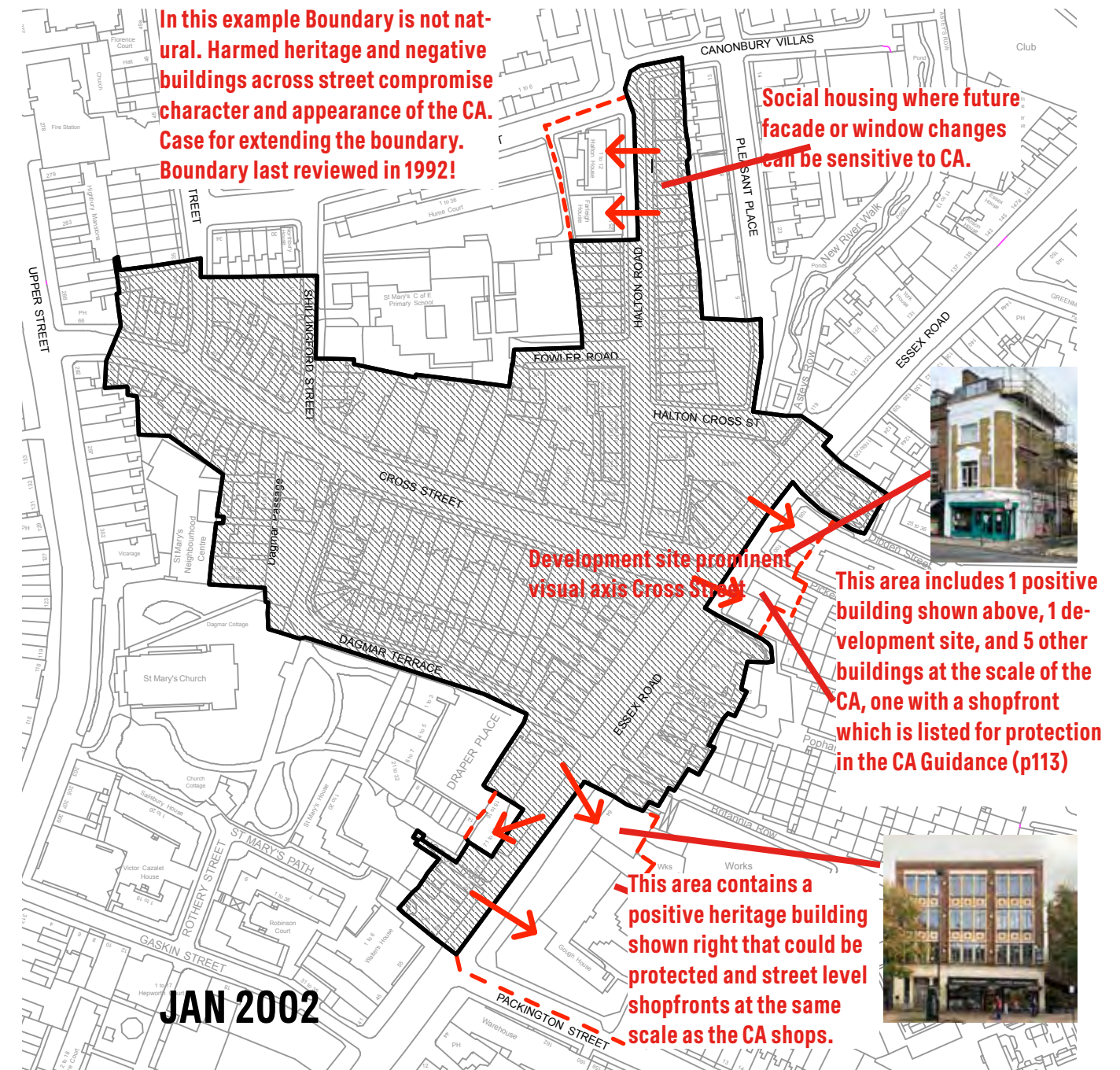

Existing CA Map with Suggested Boundary revisions.

If this Boundary is revised 11 buildings will need to be added to guidance document, following pages, as per audits regarding solar, windows, shopfronts, wall insulation, and roof extensions.

CROSS STREET

13.1 The Council will operate special policies in the Cross Street Conservation Area in order to preserve and enhance the special character and appearance of the area.

13.2 The Cross Street Conservation Area lies between two of the oldest thoroughfares in Islington, Upper Street (A1) and Essex Road (once known as Lower Street). Cross Street itself is a lively retailing street with a number of small shops now with specialist traders. The area is a mixture of retail and residential, characterised by the narrow plot-widths and small scale of 17th and 18th century buildings. There are several fine terraces in the area, some of which are listed buildings.

13.3 The Council will apply its **Local Plan** housing and shopping policies to protect and preserve the character of the area. It will not normally grant change of use from residential to any other use and it will encourage new retail uses in the **shops identified in Paragraph 13.4 below**. The Council will seek to retain other non-residential uses which contribute to the mixed use character of this conservation area.

13.4 The Council wishes to retain all locally and statutorily listed buildings, together with all the 18th and 19th century buildings and structures in the area and the shopfronts listed below **according to the states of the shopfronts**. Conservation area consent will only be granted for their removal where there are special circumstances or where the proposal would preserve or enhance the character or appearance of the conservation area.

Shopfronts with no damage.

Cross Street: 24, 30, 34, 36, 38, 40, 49, 62, 63, 71.

Essex Road: 107.

Shopfronts with moderate damage (mainly missing console brackets and cornices).

Cross Street: 2, 4, 20, 41, 42, 44, 47, 48, 50, 51, 52.

Essex Road: 66, 68, 69, 70, 93, 95, 97, 99, 101, 105, 111, 113.

Shillingford Street: 2, 4, 6, 8.

Shopfronts with severe damage (often missing stall risers and transoms, as well as console brackets and cornices).

Cross Street: 26, 46, 54, 56, 58, 60, 65, 67, 69.

Essex Road: 61, 63, 65, 67, 72, 76, 78, 88, 103, 108, 109, 110, 112.

13.5 The Council is in favour of retaining buildings which make a positive contribution to the character and appearance of a conservation area. While some buildings are protected by statutory listing, there are also many other non-listed buildings which are important to the historic and architectural character and appearance of the area.

The Council considers the shopfronts critical to the character and historic charm of the area, and **that** their loss would reduce the historic and architectural interest of the area. **Some original shopfronts remain. The Council will resist their removal and will expect any damaged ones to be restored, with the repair of missing features in keeping with Paragraph 13.4 above.**

Except in four cases, shopfronts in the area have separate doors giving access to the storeys above the shops. **The Council is in favour of having such doors and will expect the introduction of separate fire safety access doors with heritage detailing when 48, 60 or 65 Cross Street is restored or 63 Cross Street is converted back from residential use to residential and retail use.**

13.6 New buildings should conform **with the height, scale and proportions of existing buildings in the immediate area.**

13.7 Existing buildings in the area are 3-4 storeys high. Any new building which exceeds 4 storeys and which does not reflect the floor to ceiling heights of existing buildings would be detrimental to the character of the area. It would also contravene the 'Local Landmarks' policy as described in paragraph 13.15 below.

13.8 The existing buildings in the area were built on small, narrow fronted plots which gives buildings in the area a strong vertical emphasis. This verticality is one of the main physical characteristics to be conserved.

13.9 Where new shopfronts span more than one property the break between the properties should be marked with pilasters to keep the vertical stress. Single pane windows without stall risers are not appropriate for the area.

13.10 There are some small, vacant sites and several poorly designed buildings in the area, which would benefit from their redevelopment.

13.11 In considering applications for extensions and refurbishments, the Council will normally require the use of traditional materials. For new development, materials should be sympathetic to the character of the area, in terms of form, colour and texture.

13.12 The existing character and appearance of the area is created by the survival of 17th, 18th and 19th century buildings. These were built using materials suited to labour-intensive methods of construction - brick, render, stone, timber for windows and doors and slate or tile roofing. It is important that new buildings, **and** extensions and refurbishments of existing buildings, blend in with and reinforce this character; and care must be taken with the choice of brick and bond.

13.13 Modern materials - glass, steel and concrete - may be acceptable as long as the design of the new building acknowledges the scale and character of the area. Large, flat, uniform planes on elevations are not appropriate.

13.14 Shopfronts in the area should also be constructed with traditional materials such as painted timber (not tropical hardwood), iron and render/stucco. Natural aluminium is not an acceptable material. Coated aluminium or steel will only be acceptable if the design of the shopfront is appropriate for the building and enhances the conservation area. Full guidance on appropriate design and detailing is given in the **Urban Design Guide SPD**.

13.15 The Council will protect views of St Mary's Church, Upper Street, an important local landmark. New development should not compete in height with, or block views of, the church.

13.16 **The Local Plan** seeks to protect views of well known local landmarks. These buildings are key elements within Islington's townscape, creating interesting skylines and views.

13.17 St Mary's is the Parish Church at the heart of the oldest part of Islington Village. There has been a church on this site since the 16th century. The present building was constructed in 1754 although the nave was destroyed by fire in an air-raid during the Blitz and rebuilt in 1955.

13.18 Full width rear extensions higher than one storey or half width rear extensions higher than two storeys, will not normally be permitted, unless it can be shown that no harm will be caused to the character of the area.

13.19 The Council wishes to preserve the scale and integrity of the existing buildings by ensuring that extensions are subordinate to the mass and height of the main building.

13.20 The Council will not normally permit the filling in or covering over of front basement areas, or the widening of front entrance steps, or the construction of dustbin or meter enclosures.

13.21 The majority of the properties in the conservation area have front basement areas, protected by cast iron railings, which are important to the character of the area. The filling in or covering over of these areas prejudices light to the basements and spoils the appearance of the front elevation. The widening of front entrance steps, and the construction of dustbin and meter enclosures, have a detrimental effect on the area. Dustbins and meter enclosures should be discreetly located so as to be invisible from the street.

13.22 These developments will only be permitted where it can be shown that the development would preserve or enhance the character of the conservation area. In addition, the needs of disabled people will be considered exceptional to this policy and essential adaptations will be allowed.

13.23 The Council may permit roof extensions on the properties listed below; otherwise no roof extension visible from any street level position or public area will be permitted.

Cross Street: 2, 4, 41, 63, 65, 67, 69, 71.

Essex Road: 72, 87, 89, 91, 105, 107, 109, 111, 112.

Dagmar Terrace: 2, 3, 4, 5, 6, 9, 11, 12, 13, 14, 15, 16, 18, 22.

Halton Cross Street: Garage.

13.24 The Council is opposed to the erection of plant rooms and other services including water tanks and radio or satellite equipment at roof level where this can be seen from any street level or public area, including long views from side streets. Similarly, air conditioning and heat pump external units should not be visible from any street level or public area; if they could not be concealed internal units with exterior vent grilles would be acceptable.

13.25 The roofline on a street, particularly on a terrace, is a major component of the area's character. Alterations which are not in keeping with the existing buildings can have a harmful effect on the character and appearance of the conservation area. Although there is a variety of roof forms in this area, the most common is the hidden valley roof behind a parapet.

13.25 Traditional mansards using traditional materials may be permitted on the buildings listed in Paragraph 13.23 above, provided that they are correctly detailed and accord with other Council standards. The 'V' line of the butterfly roof or other original profile at the back **should be visible even if covered with External Wall Insulation. Chimneys will not need to be reinstated if they have been removed in the past.**

13.27 The Council will not normally permit new dormer windows or the widening of existing dormers, or new rooflights to the front and side slopes of existing exposed roofs.

13.28 The alteration of existing original dormers or the introduction of rooflights or additional new dormers in the exposed front or side slopes of historic buildings can be visually damaging to the conservation area.

13.29 The Council is opposed to the erection of large vent pipes on the rear elevations of commercial properties, where this is harmful to amenity. Where possible existing chimney flues should be used. Any new flues should be modest in size and painted a dark colour.

13.30 Large flues and vent pipes can often detract from the visual amenity of the area. The Council will therefore seek to ensure that these are appropriately located and are of a suitable size and design.

13.31 Existing yorkstone paving, granite kerb stones, cast iron coal-hole covers and granite setts and cobbles must be kept intact.

13.32 The street surfaces and furniture also contribute to the character and appearance of the area. The traditional street materials complement those used in the buildings and where they exist they must be kept. Where replacement is necessary the Council will insist on a modern alternative which is the closest possible to the existing.

13.33 The Council wishes to see traditional ironwork kept in the area. Parish bollards and old railings should be kept. New bollards and railings should be of a pattern agreed as suitable for the area and painted black.

13.34 Traditional ironwork also contributes to the character of the area and complements the existing buildings. There is a wide variety of modern copies of traditional railings and balconettes available to replace any which are broken beyond repair or missing.

13.35 St Mary's parish bollards are of particular historical interest and should be retained in their historic role. Existing concrete or modern metal bollards should be replaced with an appropriate traditional design.

13.36 The Council will not give advertising consent for new hoardings and will seek to remove those which do not have consent.

13.37 Advertising hoardings give an impression of clutter and lack of interest in an area. They also often obscure the nature and detailing of any building to which they are attached.

will take action against the owners, advertisers and their agents for the removal of unauthorised hoardings.

13.38 Internally illuminated signs will not normally be permitted. Other signs should be of appropriate scale and design and conform with the Urban Design Guide SPD.

13.39 Advertisements and signs can often detract from the visual amenity of the area. The Council will therefore seek to ensure that signs, display panels and advertisements are appropriately located and are of a suitable size and design. Signs that are out of scale damage various shops identified in Paragraph 13.4 above.

13.40 The Council may permit visible solar panel installations on the properties listed below if they follow design guideleines in the SPD.

Cross Street: 1/6, 7/9, 11, 13, 15, 17, 19, 21, 23, 25, 27, 29, 31, 33, 35, 28, 37/39, 41, 61, Belmont House.

Dagmar Passage: 6.

Florence Street: 28, 33.

Shillingford Street: 6, 8.

Essex Road: 61, 65, 67, 69, 88, 101, 113.

Halton Road: 8, 10, 12, 14, 18, 20, 22, 24, 26, 28, 30, 32, 34, 36, 38, 39, 40, Fircroft.

13.41 The Council may permit double or triple window or sash replacements on the properties listed below according to the styles of the windows as per Guidelines in the SPD.

Earlier windows Double Glazed(mainly having four or six panes per sash).

Cross Street: 13, 15, 17, 19, 21, 22, 23, 24, 25, 26, 27, 28, 29, 31, 30/32, 33, 35, 40, 41, 42, 44, 46, 48, 50, 51, 52, 53, 54, 55, 57, 59, 61.

Essex Road: 67, 69, 70, 74, 76, 78 85.

Dagmar Terrace: 9, 10, 11, 12, 13, 14,15, 16, 17, 18, 19, 20, 21, 22, 23.

Halton Road: 8, 12, 13, 15, 17, 18, 19, 21, 23, 24, 26, 34, 36, 38, 40.

Later windows Double or Triple (often having one or two panes per sash).

Cross Street: 2, 4, 14, 16, 18, 20, 30/32, 37/39, 38, 47, 49, 56, 58, 60, 62, 63, 65, 67, 69, 71, Belmont House.

Florence Street: 27, 28, 29,32, 33, 34.

Shillingford Street: 2, 4, 6, 7, 8, 9, 11.

Dagmar Terrace: 2, 3, 4, 5, 6, Dagmar Cottage.

Dagmar Passage: 2, 4, 6, 8, 10.

Halton Road: 42, 44, 46, 48, 50, Brookfield House, Arundel House, Fowler House, Fircroft.

Halton Cross Street Garage.

Fowler Road: 15, 16.

13.42 The Council may permit external solid wall insulation on the properties listed below according to the locations of the walls.

Rear walls Cross Street: 20, 30/32, 34/36, 38, 40, 42, 44, 46, 47, 48, 49, 50, 51, 52, 54, 56, 58, 60, 62, 63, 65, 67, 69, 71, Belmont House.

Shillingford Street: 2, 4, 6, 8.

Essex Road: 66, 68, 72, 74, 76, 78, 93, 95, 97, 99, 101, 103, 108, 110, 112.

Dagmar Terrace: 9, 10, 11, 12, 13, 14, 15, 16, 17, 18, 19, 20, 21, 22, 23.

Dagmar Passage: 2, 4, 6, 8, 10, Little Angel Workshop.

Halton Road: 42, 44, 46, 48, 50, Brookfield House, Arundel House, Fowler House.

Fowler Road: 13, 14, 15.

Front, side and rear walls.

Cross Street: 54 (rear closet wing), 56, 58, Belmont House.

Florence Street: 9, 27.

Shillingford Street: 7, 9, 11.

Essex Road: 61, 63, 65, 87, 88, 89, 91, 113.

Dagmar Terrace: 2, 3, 4, 5, 6.

Halton Road: Fircroft.

Halton Cross Street Garage.

Side walls Cross Street: 20 (east flank), 61 (east and west upper flanks).

13.43 Notwithstanding the schedules in Paragraphs 13.4, 13.23, 13.40, 13.41 and 13.42 above, the Council will take into consideration the listed status of properties when considering new buildings, extensions and refurbishments. Special regard must be paid to the retention of historic fabric where it exists. Any extensions and refurbishments which might be acceptable in townscape terms will still require careful and detailed examination, especially to establish conformance with the Net Zero Carbon SPD.

HOUSE ELEMENT AUDITS with approximate % energy losses

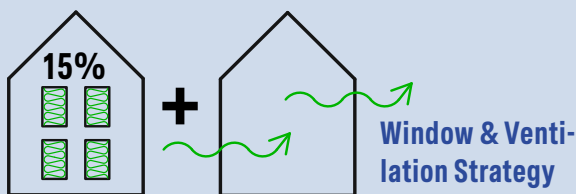
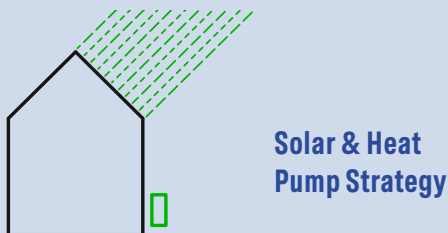
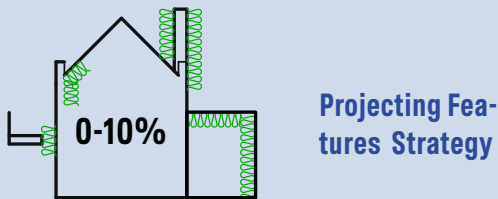
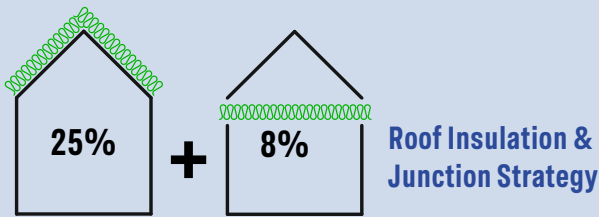

Planners who lack training in building physics or contemporary building components, continue to make decisions based on old paradigms. The current approach for innovation in planning is to leave the burden of proof on residents and their building professionals who are obliged to adhere to a complex planning process. Planning applications become an expensive gamble for residents with many choosing not to proceed because technical guidance is unclear or out of date. The 2021 LETI Climate Emergency Retrofit Guide, estimates that more than 5% of total UK Carbon emissions come from heritage or architecturally constrained homes, a figure which, on the road to net zero, must reduce by 2050.

2019 was a turning point for climate change planning policy. In February, the NPPF 2019 (National Planning Policy Framework) strengthened the environmental benefits in planning law. In June, the UK Parliament amended the Climate Change Act with the landmark legal requirement to reach Net Zero by 2050. While for conservation specifically, in February, Historic England released the 'Conservation Area Management Guidance' followed in July, by the government release of PPG 2019 (Planning Policy Guidance). Both planning documents recommend that, in order to make updated Conservation Area Management Plans, local planning authorities use positive to negative detailed mapping, thereby "identifying opportunities for beneficial change". This may go some way in assisting local planning authorities to fulfil their legal obligations under the 1990 Planning Act, which require them to regularly update and publish local conservation guidance. However, there is still much work needed for them to correct the current practice, which remains vague or has been allowed to stay unrevised for decades.

To address more rigorous environmental objectives of evolving planning law, this Toolkit does a deep dive audit into one Conservation Area neighbourhood to show what particular energy upgrades could and should be implemented in local Conservation Area Management Guides. The Toolkit advocates Building Element Audits as well as Building Audits. Some councils have already been doing Element Audits within their conservation areas (examples are in this report) but it has not yet been generally adopted. The Toolkit's in-depth approach defines the appropriate balance between heritage and energy conservation through a systematic understanding of planning concepts, building physics, current technology, manufacturers, and available products. Planning concepts of harm, significance, and the public vs the private realm are studied to develop this new paradigm of conservation planning practice.

This report is aimed at policymakers, planners, and building professionals but it can also be of great use to interested citizens in understanding our planning system and how it might be adapted for home retrofit.

